



# Meal Delivery Carts

## Low Profile, Double Door, 20 Tray Capacity

Models MDC1520S20  
MDC1418S20



### Features & Benefits

- Durable carts designed to specifically meet the meal delivery needs of hospitals (acute care), long term care and correctional facilities.
- Designed to work with unitized pellet system, heat on demand base system or insulated trays.
- Single stack rail system handles 2 trays per rail, 10 trays per compartment with a 5½" (14 cm) clearance between rails.
- Meal serving capacity per compartment is 10 each 15" x 20" (38 x 52 cm) or 14" x 18" (36 x 46 cm) fully loaded trays.
- Durable, one-piece, molded polyethylene construction ensures long term durability and reliability. Molded bottom bumpers protect walls and furniture.
- Thick foamed-in place polyurethane insulation provides added structural strength and reduces noise while transporting. High performance self venting optimizes food quality.
- Molded-in marine rail top provides an ergonomic work surface and keeps trays secure during service preparation.
- Molded-in handles on both ends make it easy to transport and maneuver.
- Insulated doors are lightweight, durable and open a full 270° to the side for easy loading and unloading.
- Nylon friction latches ensure that doors close securely. MDC1418S20 also has external lock hook for security.
- Self-draining bottom in each compartment facilitates easy cleaning.
- Casters:  
MDC1520S20: Two each 8" (20,3 cm) fixed center casters and 2 each 5" (12,7 cm) side swivel casters w/ brakes are set in a unique diamond configuration for easy steering.  
MDC1418S20: Four each 5" (12,7 cm) non-marking casters, 2 swivel with brake, 2 rigid, slightly offset.
- Non electrical.
- No assembly required.
- Available in 5 colors.

Item No. \_\_\_\_\_

Specifier Identification No. \_\_\_\_\_

Model No. \_\_\_\_\_

Quantity \_\_\_\_\_



MDC1520S20



MDC1418S20

### Approvals



© Cambro Manufacturing Company 5801 Skylab Road, Huntington Beach, California 92647-2056-U.S.A.  
Telephone (1)714 848 1555 Toll Free 800 854 7631 Customer Service Department 800 833 3003

# Meal Delivery Carts

## Low Profile, Double Door, 20 Tray Capacity

Models MDC1520S20  
MDC1418S20

Item No. \_\_\_\_\_

Specifier Identification No. \_\_\_\_\_

Model No. \_\_\_\_\_

Quantity \_\_\_\_\_

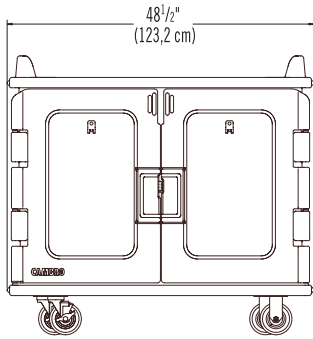

Side View

MDC1418S20

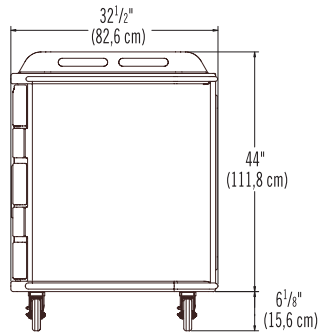

End View

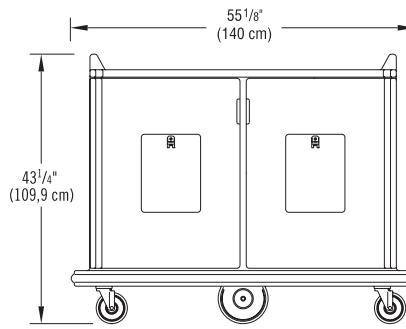

Side View

MDC1520S20

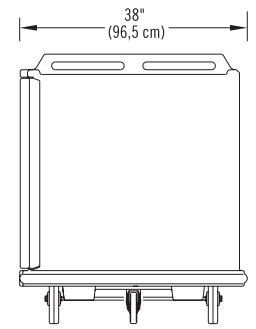

End View

### Specifications

Dimension Tolerance: +/- 1/4" (0,64 cm)

Code	Tray Capacity Per Compartment	Exterior Dimensions L x W x H	Internal Dimensions L x W x H	Case lbs./cube Case Kg/cube m <sup>3</sup>
MDC1520S20	20 each 15" x 20" (38 x 51,5 cm)	55 1/8" x 38" x 43 1/4" (140 x 96,5 x 109,9 cm)	20 1/2" x 30 1/4" x 27 1/2" (53,5 x 76,8 x 69,9 cm)	165 (55.29) 74,8 (1,57)
MDC1418S20	20 each 14" x 18" (36 x 46 cm)	48 1/2" x 32 1/2" x 44" (123,2 x 82,6 x 111,8 cm)	18 3/8" x 28 3/8" x 29" (46,7 x 71,1 x 73,7 cm)	160 (49.7) 72,6 (1,41)

### Architect Specs

These non-electric carts shall be Low Profile, Double Door, Double Compartment, 20 Tray Capacity Meal Delivery Carts, Model MDC1520S20 and MDC1418S20, manufactured by Cambro Mfg. Co., Huntington Beach, CA 92647, USA. They shall be made of one-piece, seamless, double-wall, high-density, polyethylene and shall be foam injected with polyurethane. They shall have molded-in handles on each end. They shall have molded-in marine top rails and a work surface for tray set-up and service. They shall have fully insulated doors that open a full 270°. They shall have single stack rail system that holds 2 trays per rail, 10 trays per compartment with a rail clearance of 5 1/2" (14 cm). They shall have internal nylon friction latches; one per door and the MDC1418S20 shall have an external lock hook. They shall have self-draining compartment floors that are slightly sloped. The MDC1418S20 shall have 4 each 5" (12,7 cm) casters, 2 swivel with brake and 2 rigid, off set. The MDC1520S20 shall have 2 each 8" (20,3 cm) center fixed casters and 2 each 5" (12,7 cm) side swivel casters with brakes, set in a diamond configuration. They shall require no assembly. They shall be available in 5 colors.

### Standard Colors

- Gray (180)
- Slate Blue (401)
- Granite Gray (191)
- Granite Green (192)
- Granite Sand (194)

### Approvals

