



Meal Delivery Carts

Tall Profile, Single Door, 16 Tray Capacity
Models MDC1520T16 (Formerly MDC16B)
MDC1418T16 (Formerly MDC16A)

Item No. _____

Specifier Identification No. _____

Model No. _____

Quantity _____

Features & Benefits



- Durable carts designed to specifically meet the meal delivery needs of hospitals (acute care), long term care and correctional facilities.
- Designed to work with unitized pellet system, heat on demand base system or insulated trays.
- Single stack rail system handles 2 trays per rail, 8 trays per compartment with a 5 1/4" (13,5 cm) clearance between rails.
- Serving capacity per cart:
 - MDC1418T16 - 16 each 14" x 18" (36 x 46 cm) trays
 - MDC1520T16 - 16 each 15" x 20" (38 x 52 cm) trays
- Rear mounted nylon roller menu clip keeps service instructions highly visible and easy to access.
- Durable, one-piece, molded polyurethane construction ensures long term durability and reliability. Molded bottom bumpers protect walls and furniture.
- Thick foamed-in place polyethylene insulation provides added structural strength and reduces noise while transporting.
- Molded-in marine rail top offers an ergonomic work surface and keeps trays secure during service preparation.
- Pressure molded ABS doors are lightweight, durable and open a full 270°. Can be securely locked into the bottom catch rail for easy access during serving.
- Large stainless steel paddle latch is easy to open, rust free and can be removed and cleaned without the use of tools.
- Self-draining shelf and bottom in compartments facilitates easy cleaning.
- Molded-in rear handles make it easy to transport and maneuver.
- Four each 6" (12,7 cm) casters, 2 swivel w/ brake and 2 fixed, enhance cart maneuverability and increase safety.
- Non electrical.
- No assembly required.
- Available in 11 color combinations.



MDC1418T16



MDC1520T16



Menu clip keeps service instructions clearly visible.



Durable nylon hinge pins & clips can be easily removed for cleaning.

Approvals



© 2004 Cambro Manufacturing Company 5801 Skylab Road, Huntington Beach, California 92647-2056-U.S.A.
Telephone (1)714 848 1555 Toll Free 800 854 7631 Customer Service Hot Line 800 833 3003
LIT FCST-0704

Meal Delivery Carts

Tall Profile, Single Door, 16 Tray Capacity

Models MDC1520T16 (Formerly MDC16B)

MDC1418T16 (Formerly MDC16A)

Item No. _____

Specifier Identification No. _____

Model No. _____

Quantity _____

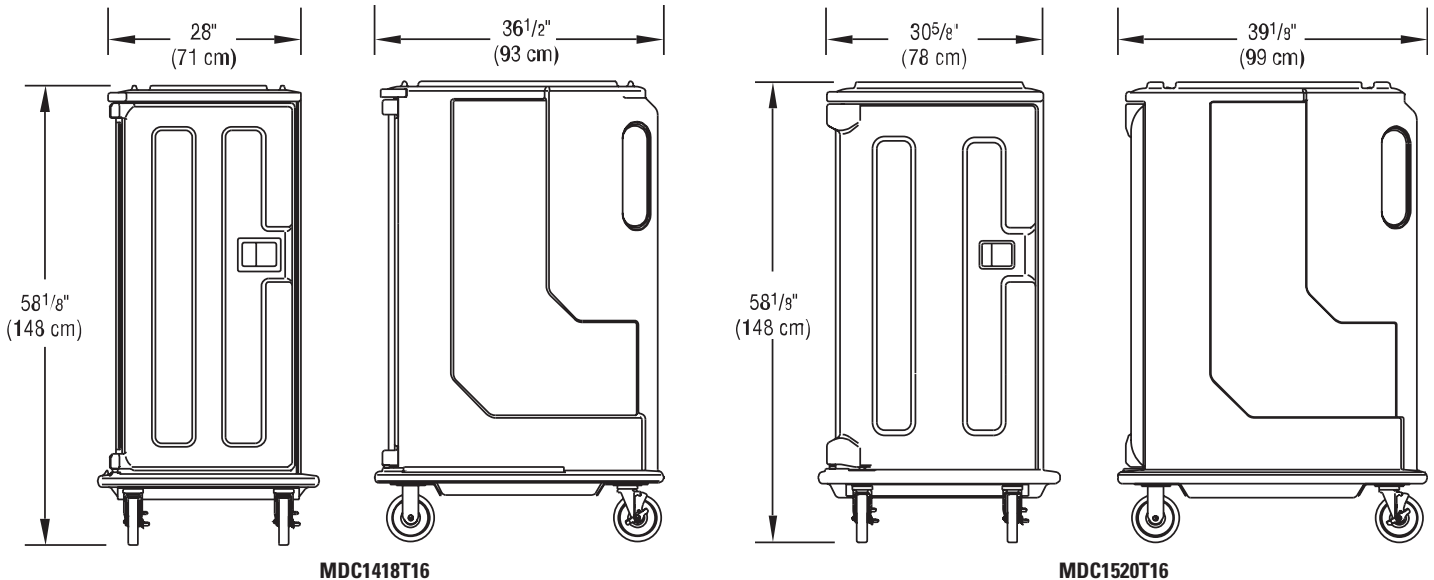

MDC1418T16

MDC1520T16

Specifications

Dimension Tolerance: +/- 1/4" (0,64 cm)

Code	Tray Capacity Per Compartment	Exterior Dimensions W x D x H	Internal Dimensions W x D x H	Case lbs./cube Case Kg/cube m ³
MDC1418T16	16 each 14" x 18" (36 x 46 cm)	28" x 36 1/2" x 58 1/8" (71 x 93 x 148 cm)	18 3/8" x 29 3/8" x 21 1/2" (46,7 x 74,6 x 54,6 cm)	151 (39.61) 68,5 (1,12)
MDC1520T16	16 each 15" x 20" (38 x 52 cm)	30 5/8" x 39 1/8" x 58 1/8" (78 x 99 x 148 cm)	20 3/8" x 30 1/2" x 21 1/2" (52,4 x 77,5 x 54,6 cm)	174 (49.62) 78,9 (1,33)

Architect Specs

The non-electrical Meal Delivery Cart shall be a vertical access, single door Meal Delivery Cart, Model..., manufactured by Cambro Mfg. Co., Huntington Beach, CA 92647 U.S.A. It shall be made of one-piece, seamless, double-wall, high-density, polyethylene and foam-injected polyurethane. It shall have a molded-in marine top rail. It shall have molded-in handles. It shall have a pressure molded ABS door that opens a full 270° and can be securely locked into the bottom catch rail. It shall have a single stack rail system that accommodates 2 trays per rail, 8 trays per compartment with a clearance of 5 1/4" (13,5 cm) between rails. It shall have a large stainless steel paddle latch that can be removed and cleaned without the use of tools. It shall have self-draining shelves. It shall have 4 each 6" (12,7 cm) casters, 2 fixed, 2 swivel, 2 w/ brake. It shall have a rear mounted nylon roller menu clip. It shall require no assembly. It shall be available in 11 color combinations.

MDC1418T16 and MDC1520T16 Covered by U.S. Patent Des. 398,727.

Standard Colors

- Dusty Rose w/Light Gray Door (400)
- Gray w/Light Gray Door (180)
- Slate Blue w/Light Gray Door (401)
- Coffee Beige w/Dark Brown Door (157)
- Dark Brown w/Dark Brown Door (131)
- Dark Brown w/Light Gray Door (731)
- Coffee Beige w/Light Gray Door (757)
- Granite Gray w/Light Gray Door (191)
- Granite Green w/Light Gray Door (192)
- Granite Red w/Light Gray Door (193)
- Granite Sand w/Light Gray Door (194)

Approvals



CAMBRO
MANUFACTURING COMPANY
www.cambro.com

© 2004 Cambro Manufacturing Company 5801 Skylab Road, Huntington Beach, California 92647-2056-U.S.A.
Telephone (1)714 848 1555 Toll Free 800 854 7631 Customer Service Hot Line 800 833 3003

Printed in USA

Central Restaurant Products