

## Portable Cambar®

### 730 Series

#### Pre-Mix

#### Domestic Models

BAR730DX - Pre-Mix

BAR730CP - Cold Plate

BAR730 - Base Model

#### Features & Benefits

- Perfect for banquets and outdoor events. Self-contained system works in a lobby, banquet room or pool side event.
- Unique detachable front lifts off, giving complete access to all storage areas for inventory and cleaning or routing soda lines, tubes and hoses.
- Sealed-in six-circuit cold plate has unique "roof top" design that directs melted water immediately into drainage channels and into the waste water bin. Keeps ice colder longer.
- Premium quality Wunder-Bar® 6-button pre-mix soda gun offers fast, low foaming delivery. Gun holster and overflow drain can be mounted on left or right side of sink. (Standard factory mounting is on the left side.)
- Oversized 7-bottle speed rail with towel grips is standard with all models. Detaches for easy cleaning. Built-in partitions keep bottles separated to prevent breakage.
- BAR730DX includes:
  - Deluxe model with one 6-button Wunder-Bar® gun, 1 sealed-in cold plate, 1 CO<sub>2</sub> chain, 1 speed rail, 1 waste water bin, 2 retainer straps, and 1 each 80 lb. (37 Kg.) center ice sink and cover.
- BAR730CP includes:
  - One sealed-in cold plate, 1 CO<sub>2</sub> chain, 1 speed rail, 1 waste water bin, 2 retainer straps, and 1 each 80 lb. (37 Kg.) center ice sink and cover.
- BAR730 includes:
  - One speed rail, 1 waste water bin, 2 retainer straps, and 1 each 80 lb. (37 Kg.) center ice sink and cover.
- Ample side storage areas will hold 8 pre-mix canisters or 4 cases of cans or bottles.
- Molded high-density polyethylene is impact resistant and easy to clean. Won't dent, crack, rust, chip or break.
- Reinforced aluminum chassis and polyurethane structural foam core ensures unsurpassed strength.
- One center ice sink, 80 lb. (37 Kg.) capacity with slide back cover for optimum sanitation.
- Four each 6" (15,2 cm) swivel casters, 2 w/ brakes, for smooth transport across carpet, cement or grass.
- Non-electrical.
- Minimal assembly required.
- Available in 5 solid colors and 6 color combinations.

Item No. \_\_\_\_\_

Specifier Identification No. \_\_\_\_\_

Model No. \_\_\_\_\_

Quantity \_\_\_\_\_



BAR730DX



BAR730DX  
(Shown with optional Wire Shelving)



Detachable front for easy access to inventory and routing lines, tubes and hoses.



Premium quality 6-button, pre-mix soda gun by Wunder-Bar®.

#### Approvals



# Portable Cambar®

## 730 Series

### Pre-Mix

#### Domestic Models

BAR730DX - Pre-Mix

BAR730CP - Cold Plate

BAR730 - Base Model

Item No. \_\_\_\_\_

Specifier Identification No. \_\_\_\_\_

Model No. \_\_\_\_\_

Quantity \_\_\_\_\_

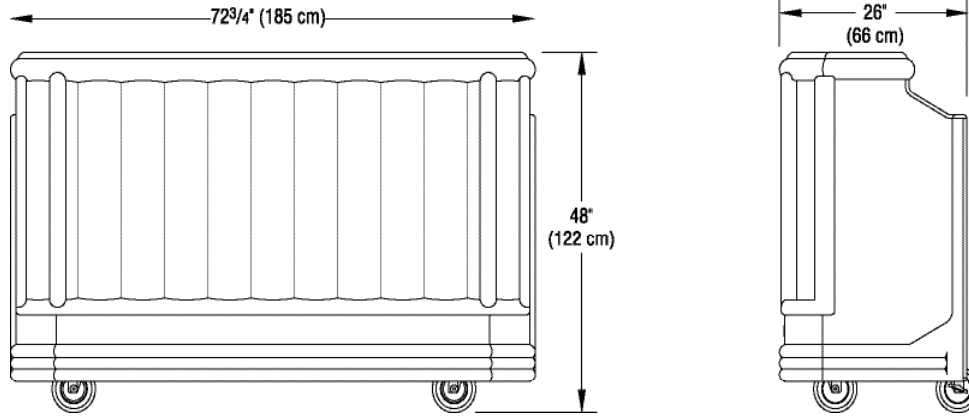

BAR730DX/BAR730CP/BAR730

## Specifications

Dimension Tolerance: +/- 1/4" (0,64 cm)

Code	Description	Overall Dimensions L x W x H	Case lbs./cube Kg/m <sup>3</sup>
BAR730DX	Deluxe model with one 6-button Wunder-Bar® gun, 1 sealed-in cold plate, 1 CO <sub>2</sub> chain, 1 7-bottle speed rail, 1 waste water bin, 2 retainer straps, and 1 each 80 lb. (37 Kg.) center ice sink and cover.	72 3/4" x 26" x 48" (185 x 66 x 122 cm)	300 (58.75) 136 (1,61)
BAR730CP	1 sealed-in cold plate, 1 CO <sub>2</sub> chain, 1 7-bottle speed rail, 1 waste water bin, 2 retainer straps, and 1 each 80 lb. (37 Kg.) center ice sink and cover.	72 3/4" x 26" x 48" (185 x 66 x 122 cm)	290 (58.75) 132 (1,65)
BAR730	1 7-bottle speed rail, 1 waste water bin, 2 retainer straps, and 1 each 80 lb. (37 Kg.) center ice sink and cover.	72 3/4" x 26" x 48" (185 x 66 x 122 cm)	257 (58.75) 117 (1,65)

## Optional Accessories

- Wire Shelving  730WS
  - Retaining Strap  730STP (2 each w/Cambar)
  - Retaining Chain for CO<sub>2</sub> canisters  730CHN (1 each w/Cambar)
  - 7-Bottle Speed Rail  730SR (1 each w/Cambar)
  - Custom Decorating Kit  730CKIT
- (Includes instructions, 18 each mounting plates, 18 each washers, 18 each wing nuts)

## Standard Colors

- Two-tone Gray Marble (188)  Black (110)  Two-tone Brown Mahogany (189)
- Granite Gray (191)  Granite Green (192)  Granite Red (193)
- Granite Sand (194)  Granite Gray w/Black base (420)
- Granite Green w/Black base (421)  Granite Red w/Black base (422)
- Granite Sand w/Black base (423)

## Architect Specs

The pre-mix portable bar shall be a Cambar, 730 Series, manufactured by Cambro Mfg. Co., Huntington Beach, CA 92648 U.S.A. It shall be a Cambro Model... It shall be constructed of molded high-density polyethylene and foam-injected polyurethane with a built-in bumper. It shall have an access passage in the middle compartment for a water line or electrical cord. It shall have a step-down drink preparation area that can be fit with 2 glass rail mats. It shall have 4 each 6" (15,2 cm) swivel casters, 2 w/ brakes, on a molded-in aluminum chassis. It shall be available with a Premium 6-button Wunder-Bar® pre-mix soda gun, sealed-in 6-circuit "roof top" design cold plate and CO<sub>2</sub> chain. It shall have an oversized, 7-bottle partitioned speed rail with towel grips, a waste-water bin and an 80 lb (37 Kg.) center ice sink and slide-back cover. It shall have 2 retainer straps. It shall have a detachable front that lifts off. All models shall be available in 4 solid colors and 2 color combinations.

## Approvals



© 2002 Cambro Manufacturing Company 5801 Skylab Road, Huntington Beach, California 92647-2056-U.S.A.  
Telephone (1)714 848 1555 Toll Free 800 854 7631 Customer Service Hot Line 800 833 3003

Printed in USA