

Ingredient Bins

Standard

- Models IBSF27 – 27 gallon (102 L)
- IB32 – 32 gallon (121 L)
- IB36 – 34 gallon (129 L)
- IB44 – 43 gallon (161 L)

Item No. _____

Specifier Identification No. _____

Model No. _____

Quantity _____



Features & Benefits

- Stores and transports a wide variety of dry ingredients such as flour, sugar, rice or grains. Perfect for restaurants, food manufacturers or commissaries.
- Available in 27, 32, 34, and 43 gallon (102, 121, 129, 161 L) capacity to meet standard industry requirements for storage and transportation of bulk foods.
- One-piece, seamless single-wall polyethylene bin construction is extremely durable. Won't rust or corrode. Liquids and dry foods will not stick or seep between seams.
- FDA accepted material. Meets all food contact requirements and eliminates need for liners.
- Smooth interior and exterior are easy to clean.
- Injection molded Camwear® polycarbonate lids are transparent, break resistant and offer quick and easy identification of contents. Slide-back feature for easy access.
- Working height permits storage under standard work tables.
- Heavy-duty 3" (7,6 cm) casters, 2 front swivel, 2 fixed, are bolted into molded-in steel plates and will not pull out or fall off.
- No assembly required.
- Available in White (148) only with Clear (135) cover.



IBSF27



IB32



IB36



IB44

Approvals



Ingredient Bins

Standard

Models IBSF27 – 27 gallon (102 L)
 IB32 – 32 gallon (121 L)
 IB36 – 34 gallon (129 L)
 IB44 – 43 gallon (161 L)

Item No. _____

Specifier Identification No. _____

Model No. _____

Quantity _____

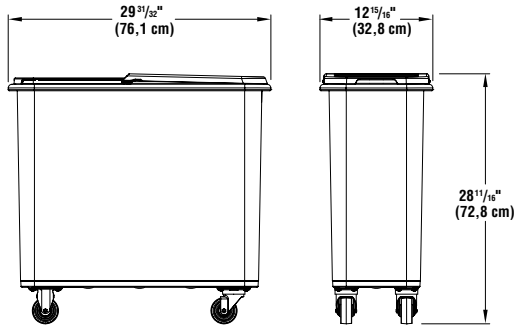

IBSF27

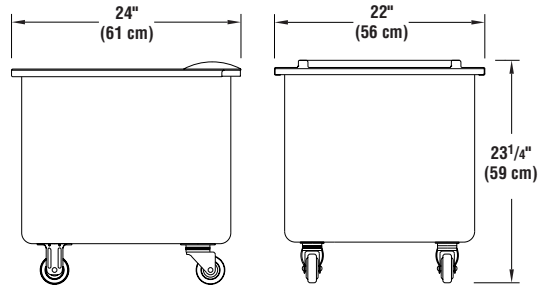

IB32

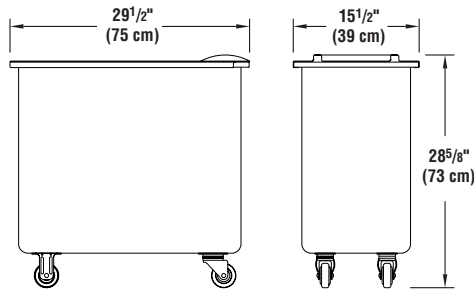

IB36

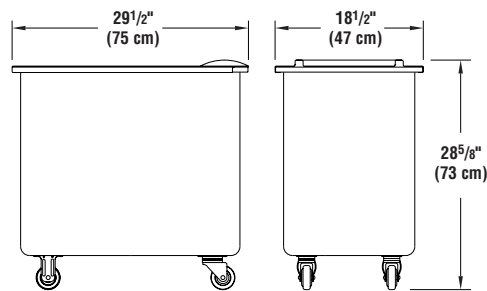

IB44

Specifications

Dimension Tolerance: +/- 1/4" (0,64 cm)

Code	Description	Volume Capacity	Load Capacity		Exterior Dimensions W x D x H	Case lbs./cube Kg/m ³
			Sugar	Flour		
IBSF27	27 gal. Ingredient Bin (102 L)	3.56 Cubic feet (0,100) Cubic meters	216 lbs. (98 kg.)	150 lbs. (68 kg.)	12 ¹⁵ / ₁₆ " x 29 ³¹ / ₃₂ " x 28 ¹¹ / ₁₆ " (32,8 x 76,1 x 72,8 cm)	28.5 (6.91) 11,2 (0,196)
IB32	32 gal. Ingredient Bin (121 L)	4.28 Cubic feet (0,121) Cubic meters	215 lbs. (97,5 kg.)	160 lbs. (73 kg.)	22" x 24" x 23 ¹ / ₄ " (56 x 61 x 59 cm)	27.75 (7.50) 13 (0,21)
IB36	34 gal. Ingredient Bin (129 L)	4.54 Cubic feet (0,128) Cubic meters	252 lbs. (114 kg.)	180 lbs. (82 kg.)	15 ¹ / ₂ " x 29 ¹ / ₂ " x 28 ⁵ / ₈ " (39 x 75 x 73 cm)	30 (8.51) 14 (0,24)
IB44	43 gal. Ingredient Bin (161 L)	5.69 Cubic feet (0,161) Cubic meters	320 lbs. (145 kg.)	230 lbs. (104 kg.)	18 ¹ / ₂ " x 29 ¹ / ₂ " x 28 ⁵ / ₈ " (47 x 75 x 73 cm)	30.75 (9.14) 14 (0,26)

Architect Specs

The Ingredient Bins shall be Cambro Model..., manufactured by Cambro Mfg. Co., Huntington Beach, CA 92648 U.S.A. Each unit shall be one piece, seamless, single-wall molded construction made of FDA Approved white polyethylene. Unit capacity shall range from 27 - 43 gallons (102 - 161 L) and/or 3.56 - 5.69 cu. ft. (0,100 - 0,161 cubic meters).

It shall have four each 3" (7,6 cm) casters with 1¹/₄" (3,2 cm) wide tread, 2 front swivel and 2 fixed, mounted on molded-in steel plates. It shall have an injection molded, transparent, slide-back polycarbonate lid. It shall not exceed 29" (73,6 cm) in height so that it can store under standard work tables. It shall be available in white only with a clear cover.

Approvals



© Cambro Manufacturing Company 5801 Skylab Road, Huntington Beach, CA 92647-2056, U.S.A.
 Telephone 714 848 1555 Toll Free 800 854 7631 Customer Service Department 800 833 3003