

## Camcrisper®

Model CC32 - 32 gallon (121 L)

StoreSafe

### Features & Benefits

- Use as part of a HACCP food safety program to help prevent cross contamination and minimizes unnecessary handling. Create a completely self-contained system for storing, washing and transporting bulk produce.
- First, transfer produce out of cartons into clean Camcrisper bin, cover and roll into cooler for safe storage. When ready to prep, roll bin out, wash and rinse produce in Camcrisper, never placing produce onto contaminated drain counters next to sink drains! Roll clean produce into kitchen for prepping.
- Volume capacity is 4.35 cubic feet (1,23 cubic meters).
- Holding capacity is:
  - Unfinished iceberg lettuce - 1 case (24 heads)
  - Finished iceberg lettuce - 1.75 cases (42 heads)
- One-piece, seamless single-wall polyethylene construction is extremely durable. Won't rust or corrode. Liquids and dry foods will not stick or seep between seams.
- FDA accepted material. Meets all food contact requirements and eliminates need for liners. Will not transfer odors or flavors.
- Clear polycarbonate slide-back lid lets you check contents and add ice as needed.
- NSF listed threaded faucet drain with standard hose hook-up makes draining and cleaning easy.
- Polycarbonate drain shelf keeps produce above standing water.
- Four each 3" (7,6 cm) extra wide sturdy casters, 2 swivel and 2 fixed, offer easy maneuvering and handling.
- No assembly required
- Available in white only with a clear cover.

Item No. \_\_\_\_\_

Specifier Identification No. \_\_\_\_\_

Model No. \_\_\_\_\_

Quantity \_\_\_\_\_

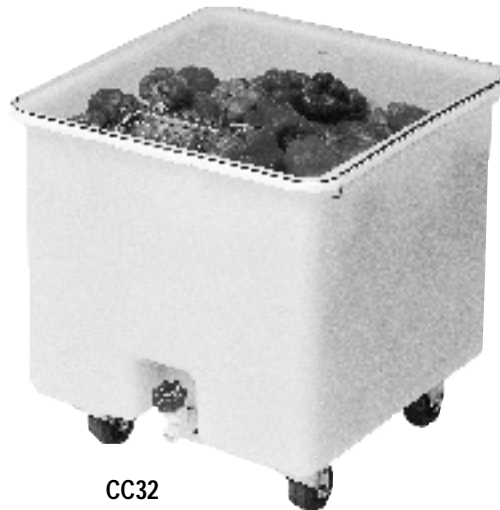

CC32

### Approvals



# Camcrisper®

Model CC32 - 32 gallon (121 L)

Item No. \_\_\_\_\_

Specifier Identification No. \_\_\_\_\_

Model No. \_\_\_\_\_

Quantity \_\_\_\_\_

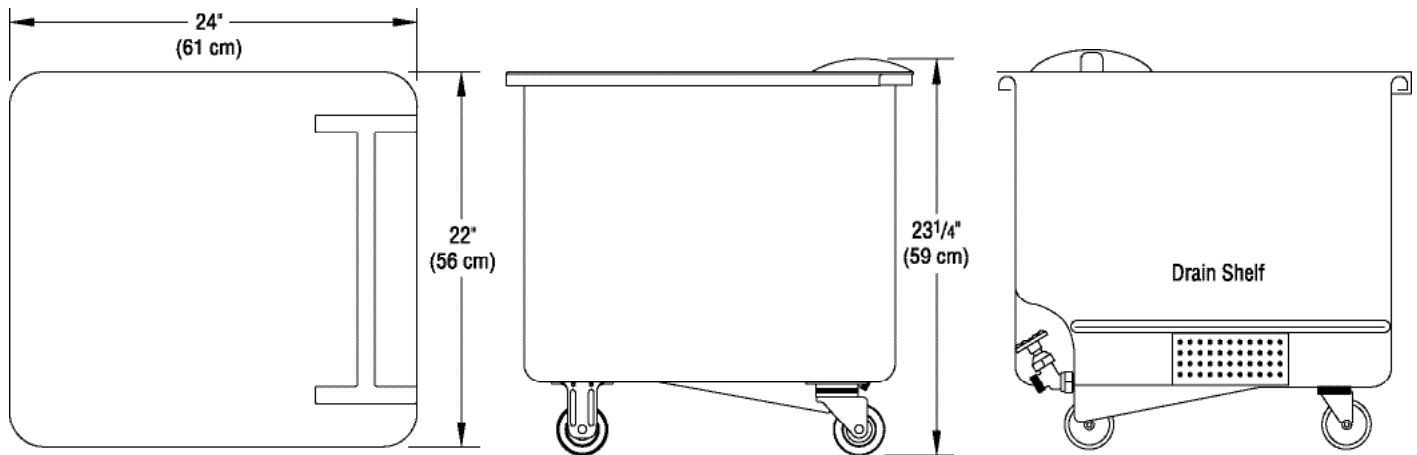

## Specifications

Dimension Tolerance: +/- 1/4" (0,64 cm)

Code	Description	Volume Capacity	Load Capacity (Lettuce)	Exterior Dimensions W x D x H	Case lbs./cube Kg/m <sup>3</sup>
CC32	Vegetable Crisper	4.35 Cubic Feet (1,23 Cubic Meters) 32 gal. (121 L)	24 heads (unfinished) 42 heads (finished)	22" x 24" x 23 1/4" (56 x 61 x 59 cm)	30 (7.66) 114 (0,21)

## Architect Specs

The vegetable crisper shall be a Camcrisper Vegetable Crisper, manufactured by Cambro Mfg. Co., Huntington Beach, CA 92648 U.S.A. It shall be a Cambro Model CC32. It shall be a one piece, seamless, single wall molded construction made of FDA Approved white polyethylene. Capacity shall be 32 gallons (121 L) and/or 4.35 cubic feet. (1,23 cubic meters). It shall be able to accommodate 24 heads of unfinished iceberg lettuce or 42 heads of finished iceberg lettuce. It shall have four each 3" (7,6 cm) casters, 2 swivel and 2 fixed. It shall have one polycarbonate drain shelf and an NSF listed, threaded faucet drain. It shall be available in white only with a clear cover.

## Approvals



**CAMBRO**  
MANUFACTURING COMPANY  
<http://www.cambro.com>

© 2002 Cambro Manufacturing Company 5801 Skylab Road, Huntington Beach, California 92647-2056-U.S.A.  
Telephone (1)714 848 1555 Toll Free 800 854 7631 Customer Service Hot Line 800 833 3003

Printed in USA