

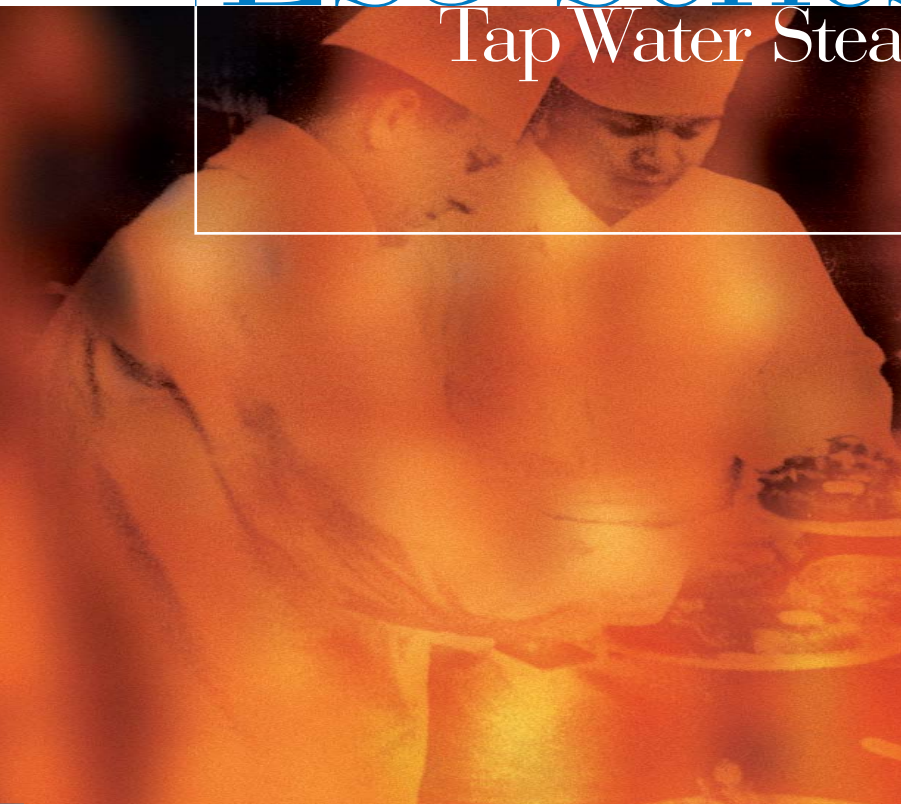

EmberGlo®

ES5 Series

Tap Water Steamers



Engineered to handle a
demanding workload with ease

ES5 Series

Tap Water Steamers Half Pan Size



Wider Menu Variety

Not too long ago, the primary functions of food steamers were to re-hydrate bakery items, plump cook a hot dog or quick thaw frozen foods. Today, foodservice operators have discovered they can broaden their menu by making more use of steam heat.

From appetizers to desserts, we found that steam heat can be used to cook, warm, re-hydrate and freshen almost every type of pre-cooked, refrigerated, fresh or frozen food.

Our ES5 series steamer lets you prepare your most popular menu items in advance and refrigerate until you're ready to steam and serve. All the precious moisture, texture and flavor of your foods can be maintained through the convenient use of steam heat.

Simple to Use—Easy to Operate

The ES5 series food steamers have been engineered to handle the most demanding workload. ES5 steamers are furnished with an adjustable lid hinge that gives you the option of opening the lid to either a 60° or 90° position. The hinge also includes counter-balanced springs to prevent the lid from slamming.

Cooking your favorite dishes has never been so easy. On your command, the EmberGlo steamer starts working almost immediately—injecting gentle spurts of tap water into the generator, producing clean, hot steam.

The ES5PB and ES5T direct water hook up models include a six foot flexible hose and quick disconnect fittings...making installation a snap! Direct-water hook-up provides a constant water supply to the unit and allows the water line to be removed for easy cleaning—without shutting off the kitchen's water supply.

Our ES5M, ES5PBS and ES5TS portable models have self contained one gallon capacity water pans—allowing these units to be easily moved from one place to another for your operating convenience... the perfect model for any task.

EmberGlo's ES5T and ES5TS automatic models include timers, offering you even greater possibilities to expand your menu.

The main control timer may be set for any cooking time, automatically injecting steam at 20 second intervals. A buzzer signal and light will alert you when the cooking cycle is complete. These models also include a manual button, allowing you to hydrate rolls, melt cheese, warm a deli sandwich—all at the push of a button.



ES5 Series - Direct Hookup
Model ES5T

ES5 Series - Direct Hookup
Model ES5PB

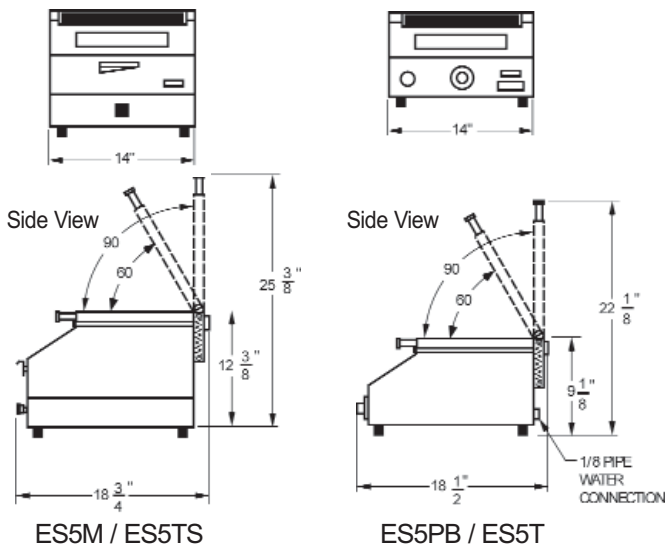

Engineered to handle a
demanding workload with ease

ES5 Series

Tap Water Steamers Half Pan Size



Wider Menu Variety

Not too long ago, the primary functions of food steamers were to re-hydrate bakery items, plump cook a hot dog or quick thaw frozen foods. Today, foodservice operators have discovered they can broaden their menu by making more use of steam heat.

From appetizers to desserts, we found that steam heat can be used to cook, warm, re-hydrate and freshen almost every type of pre-cooked, refrigerated, fresh or frozen food.

Our ES5 series steamer lets you prepare your most popular menu items in advance and refrigerate until you're ready to steam and serve. All the precious moisture, texture and flavor of your foods can be maintained through the convenient use of steam heat.

Simple to Use—Easy to Operate

The ES5 series food steamers have been engineered to handle the most demanding workload. ES5 steamers are furnished with an adjustable lid hinge that gives you the option of opening the lid to either a 60° or 90° position. The hinge also includes counter-balanced springs to prevent the lid from slamming.

Cooking your favorite dishes has never been so easy. On your command, the EmberGlo steamer starts working almost immediately—injecting gentle spurts of tap water into the generator, producing clean, hot steam.

The ES5PB and ES5T direct water hook up models include a six foot flexible hose and quick disconnect fittings...making installation a snap! Direct-water hook-up provides a constant water supply to the unit and allows the water line to be removed for easy cleaning—without shutting off the kitchen's water supply.

Our ES5M, ES5PBS and ES5TS portable models have self contained one gallon capacity water pans—allowing these units to be easily moved from one place to another for your operating convenience... the perfect model for any task.

EmberGlo's ES5T and ES5TS automatic models include timers, offering you even greater possibilities to expand your menu.

The main control timer may be set for any cooking time, automatically injecting steam at 20 second intervals. A buzzer signal and light will alert you when the cooking cycle is complete. These models also include a manual button, allowing you to hydrate rolls, melt cheese, warm a deli sandwich—all at the push of a button.



ES5 Series - Direct Hookup
Model ES5T

ES5 Series - Direct Hookup
Model ES5PB

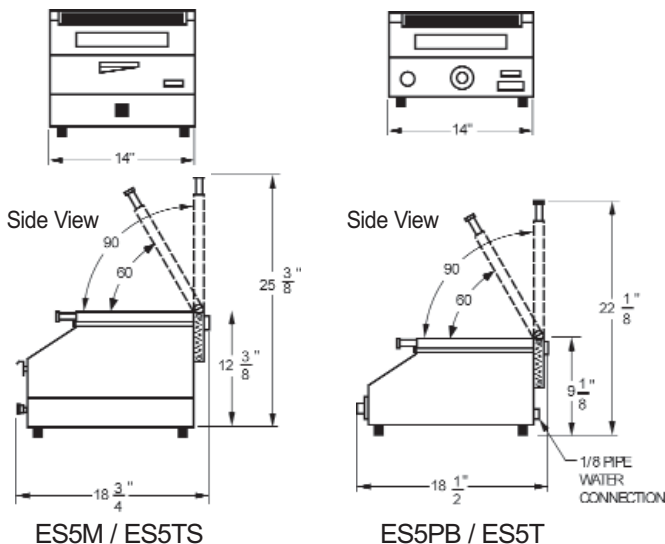



ES5 Series - Self-Contained Water Supply Model ES5TS



ES5 Series - Self-Contained Water Supply Model ES5M



Specialized Features

Type: Adjustable hinged top opening
 Food Pan: 4" deep, half size
 Tap water operation
 No hood system needed
 Self contained removable water pan or direct water hookup

- ES5 Series - 120V, 1500 watts, 12.5 amps
- ES5PBS - **Manual push button** - self contained water supply
- ES5M - **Manual pump** - self contained water supply
- ES5TS - **Automatic timer** - self contained water supply
- ES5PB - **Manual push button** - water line connection
- ES5T - **Automatic timer** - water line connection



Tortilla Rack 5608-71

Steamer - Generator Cleaning Brush 8450-62



Mesh Food Pan w/ Separator 5608-53



Egg Poacher 5608-61

- ES5 1800 Series - 120V, 1800 watts, 15 amps
 Temperature recovery time decreased by 20%
- ES5M18 - **Manual pump** - self contained water supply
- ES5TS18 - **Automatic timer** - self contained water supply
- ES5PB18 - **Manual push button** - water line connection

Accessories for ES5 Series

Item Descriptions	Part Number	Dimensions	Shipping Weight
Tortilla Rack w/ Handle	5608-71	10 1/4"L x 7 5/8"W x 3 1/4"H	1 lb
Mesh Food Pan Grid & Separator	5608-53	10 1/8"L x 8 5/8"W x 3"H	1 1/2 lb
Three in One Basket Set w/ Handle	5608-70	10 3/8"L x 8 1/8"W x 3"H	1 1/2 lb
1/2 Pan Size Basket w/ Handle	5608-72	10 3/8"L x 8 1/8"W x 3"H	1 1/4 lb
Two of 1/4 Pan Size Basket w/ Handle	5608-73	7 7/8"L x 5 1/8"W x 3"H	1 lb
Egg Poacher	5608-61	12 3/4"L x 10 1/2"W	4 lb
Steamer Generator Cleaning Brush	8450-62	7 3/4"L	1/2 lb

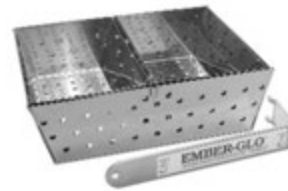

Half Pan Size Basket - 5608-72
 Quarter Pan Size Basket (2 pk) - 5608-73
 3 in One Basket Set (1 Half and 2 Quarters) - 5608-70
 (Basket Sets come with a Handle)

Specifications

Model Number	Type	Dimensions	Electrical	Electrical Connection	Model Number
ES5PBS	Food steamer/cooker with self-contained water supply, removable water drawer and push button operation	14" Wide 18 3/4" Deep 25 3/8" High	120V-60Hz, 1500 watts, 12.5 amps	3 wire cord	40 lbs.
ES5M	Food steamer/cooker with self-contained water supply, removable water drawer and manual pump operation		120V-60Hz, 1500 watts, 12.5 amps		48 lbs.
ES5M18			120V-60Hz, 1800 watts, 15 amps		49 lbs.
ES5TS	Food steamer/cooker with self-contained water supply, removable water drawer, 30 minuter timer, single shot puts button operation, ready light and buzzer	120V-60Hz, 1500 watts, 12.5 amps	49 lbs.		
ES5TS18		120V-60Hz, 1800 watts, 15 amps			
ES5PB	Food steamer/cooker with direct water hook-up, 6' hose with quick connect fittings and push button operation	14" Wide 18 3/4" Deep 22 1/8" High	120V-60Hz, 1500 watts, 12.5 amps		40 lbs.
ES5PB18			120V-60Hz, 1800 watts, 15 amps		
ES5T	Food steamer/cooker with direct water hook-up, 6' hose with quick connect fittings, 30 minute timer, single shot push button, ready light and buzzer		120V-60Hz, 1500 watts, 12.5 amps	41 lbs.	

All models contain 4" deep, half size food pan.
 For Export Only: Models ES5M and ES5PB available for export with 220V-50Hz., 1500 watts, 6.8 amps.
 Export models shipped less cord and U.S. agency approvals.
 Fixed timed cooking cycle available, call factory for further information



*Now you can have all the fresh,
flavorful advantages of food steaming –
plus the proven dependability and
efficiency of EmberGlo engineering
without the restriction of supplying
distilled or demineralized water. It all
adds up to greater convenience for you.*



EmberGlo

EmberGlo

A Division of Midea International Inc.

4140 West Victoria Street

Chicago, Illinois 60646

tel 773.604.8700

fax 773.604.4070

web www.emberglo.com

e-mail sales@emberglo.com



Quality Designed for Proven Performance



ES5 Series - Self-Contained Water Supply Model ES5TS



ES5 Series - Self-Contained Water Supply Model ES5M



Specialized Features

Type: Adjustable hinged top opening
 Food Pan: 4" deep, half size
 Tap water operation
 No hood system needed
 Self contained removable water pan or direct water hookup

- ES5 Series - 120V, 1500 watts, 12.5 amps
- ES5PBS - **Manual push button** - self contained water supply
- ES5M - **Manual pump** - self contained water supply
- ES5TS - **Automatic timer** - self contained water supply
- ES5PB - **Manual push button** - water line connection
- ES5T - **Automatic timer** - water line connection



Tortilla Rack 5608-71

Steamer - Generator Cleaning Brush 8450-62



Mesh Food Pan w/ Separator 5608-53



Egg Poacher 5608-61

- ES5 1800 Series - 120V, 1800 watts, 15 amps
 Temperature recovery time decreased by 20%
- ES5M18 - **Manual pump** - self contained water supply
- ES5TS18 - **Automatic timer** - self contained water supply
- ES5PB18 - **Manual push button** - water line connection

Accessories for ES5 Series

Item Descriptions	Part Number	Dimensions	Shipping Weight
Tortilla Rack w/ Handle	5608-71	10 1/4"L x 7 5/8"W x 3 1/4"H	1 lb
Mesh Food Pan Grid & Separator	5608-53	10 1/8"L x 8 5/8"W x 3"H	1 1/2 lb
Three in One Basket Set w/ Handle	5608-70	10 3/8"L x 8 1/8"W x 3"H	1 1/2 lb
1/2 Pan Size Basket w/ Handle	5608-72	10 3/8"L x 8 1/8"W x 3"H	1 1/4 lb
Two of 1/4 Pan Size Basket w/ Handle	5608-73	7 7/8"L x 5 1/8"W x 3"H	1 lb
Egg Poacher	5608-61	12 3/4"L x 10 1/2"W	4 lb
Steamer Generator Cleaning Brush	8450-62	7 3/4"L	1/2 lb

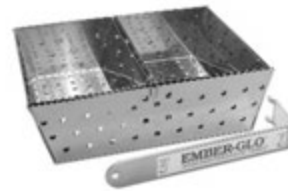

Half Pan Size Basket - 5608-72
 Quarter Pan Size Basket (2 pk) - 5608-73
 3 in One Basket Set (1 Half and 2 Quarters) - 5608-70
 (Basket Sets come with a Handle)

Specifications

Model Number	Type	Dimensions	Electrical	Electrical Connection	Model Number
ES5PBS	Food steamer/cooker with self-contained water supply, removable water drawer and push button operation	14" Wide 18 3/4" Deep 25 3/8" High	120V-60Hz, 1500 watts, 12.5 amps	3 wire cord	40 lbs.
ES5M	Food steamer/cooker with self-contained water supply, removable water drawer and manual pump operation		120V-60Hz, 1500 watts, 12.5 amps		48 lbs.
ES5M18			120V-60Hz, 1800 watts, 15 amps		49 lbs.
ES5TS	Food steamer/cooker with self-contained water supply, removable water drawer, 30 minuter timer, single shot puts button operation, ready light and buzzer	120V-60Hz, 1500 watts, 12.5 amps	49 lbs.		
ES5TS18		120V-60Hz, 1800 watts, 15 amps			
ES5PB	Food steamer/cooker with direct water hook-up, 6' hose with quick connect fittings and push button operation	14" Wide 18 3/4" Deep 22 1/8" High	120V-60Hz, 1500 watts, 12.5 amps		40 lbs.
ES5PB18			120V-60Hz, 1800 watts, 15 amps		
ES5T	Food steamer/cooker with direct water hook-up, 6' hose with quick connect fittings, 30 minute timer, single shot push button, ready light and buzzer		120V-60Hz, 1500 watts, 12.5 amps	41 lbs.	

All models contain 4" deep, half size food pan.
 For Export Only: Models ES5M and ES5PB available for export with 220V-50Hz., 1500 watts, 6.8 amps.
 Export models shipped less cord and U.S. agency approvals.
 Fixed timed cooking cycle available, call factory for further information



*Now you can have all the fresh,
flavorful advantages of food steaming –
plus the proven dependability and
efficiency of EmberGlo engineering
without the restriction of supplying
distilled or demineralized water. It all
adds up to greater convenience for you.*



EmberGlo

EmberGlo

A Division of Midea International Inc.

4140 West Victoria Street

Chicago, Illinois 60646

tel 773.604.8700

fax 773.604.4070

web www.emberglo.com

e-mail sales@emberglo.com



Quality Designed for Proven Performance