



CTF

Countertop Freezer & Ice Cream Freezer

KEY ASPECTS

SPECIAL FEATURES:

- 3 adjustable shelves (CTF-3HC)
- 2 adjustable shelves (CTF-2HC)
- Right hinge self closing door
- Environmentally friendly hydrocarbon refrigerant

OPTIONS:

- Lighted door graphic
- Graphics



Complies with 2017 DOE standards for commercial freezer and ice cream freezer



TECHNICAL SUMMARY

MODEL	SIZE				ELECTRICAL			REFRIGERATION			OTHER	
	Dimensions (inches) Width x Depth x Height	Cubic Feet	Net Weight (lbs.)	Shipping Weight (lbs.)**	Voltage/Hz/Phase	Running Amps	Max kWh/24hr	Compressor HP	Refrigerant	Temperature	No. of Optional Baskets	Container Quantity
CTF-2HC	22 1/2 x 20 3/4 x 20 7/8	1.9	88	99	115/60/1	2.1	2.4	1/4	R-290	-15° to +15°F	2	304
CTF-3HC	24 x 21 x 26 5/8	3.4	108	119	115/60/1	3.6	2.8	2/5	R-290	-15° to +15°F	3	171

**Does not include weight of pallets when needed



ENERGY PERFORMANCE VERIFIED
RENDIMENT ENERGETIQUE VERIFIE

CTF-3HC

CTF-2HC

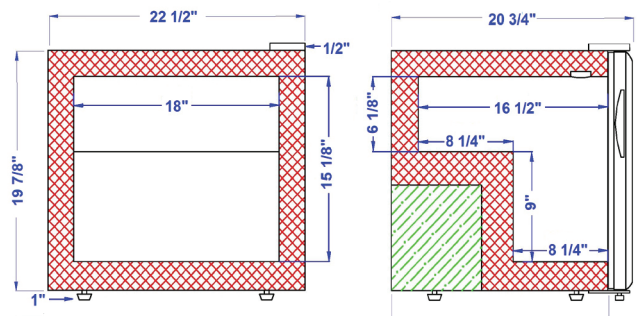

CTF-3HC

