

PLAN VIEW

GROMMET

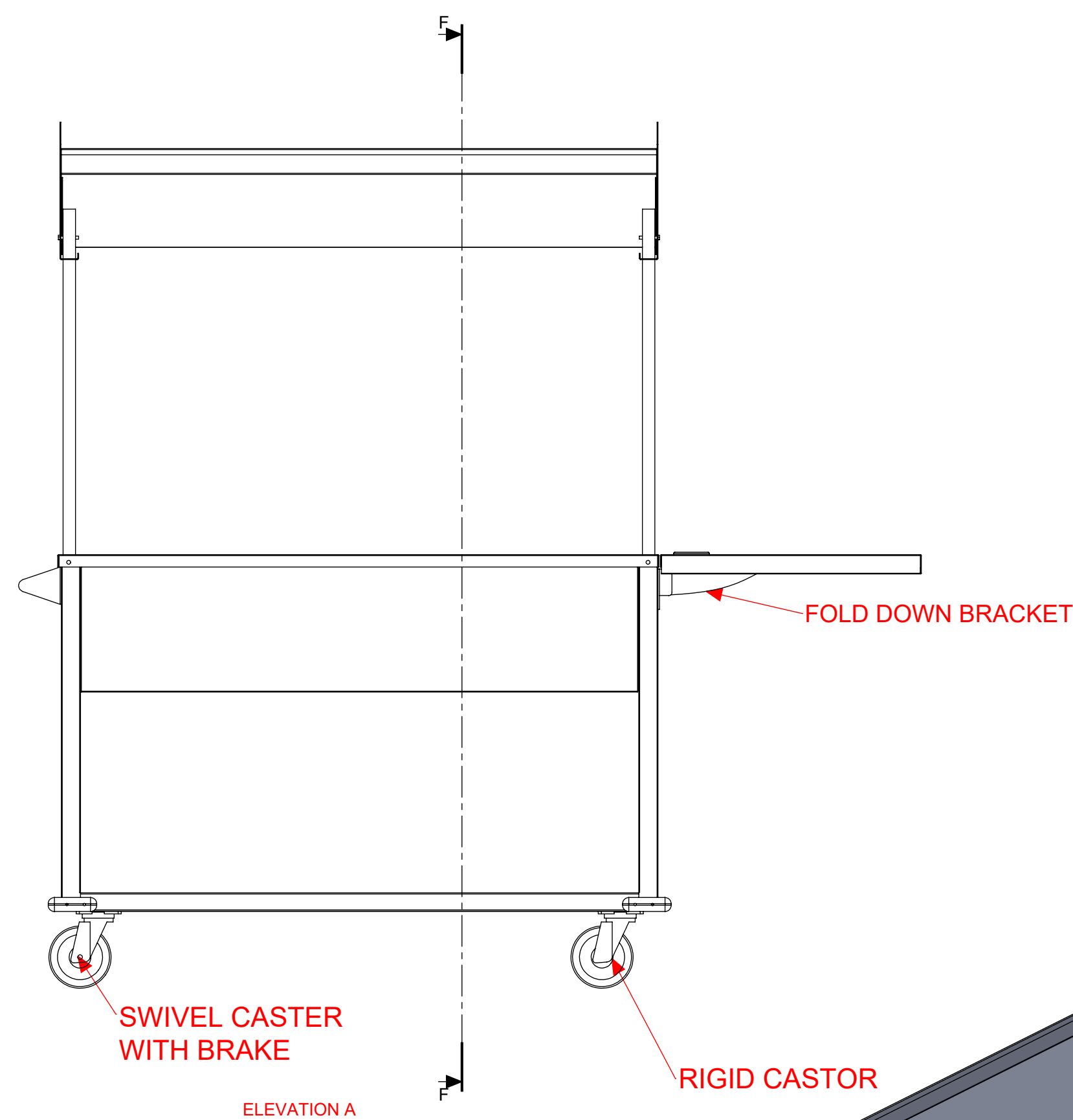

ELEVATION A

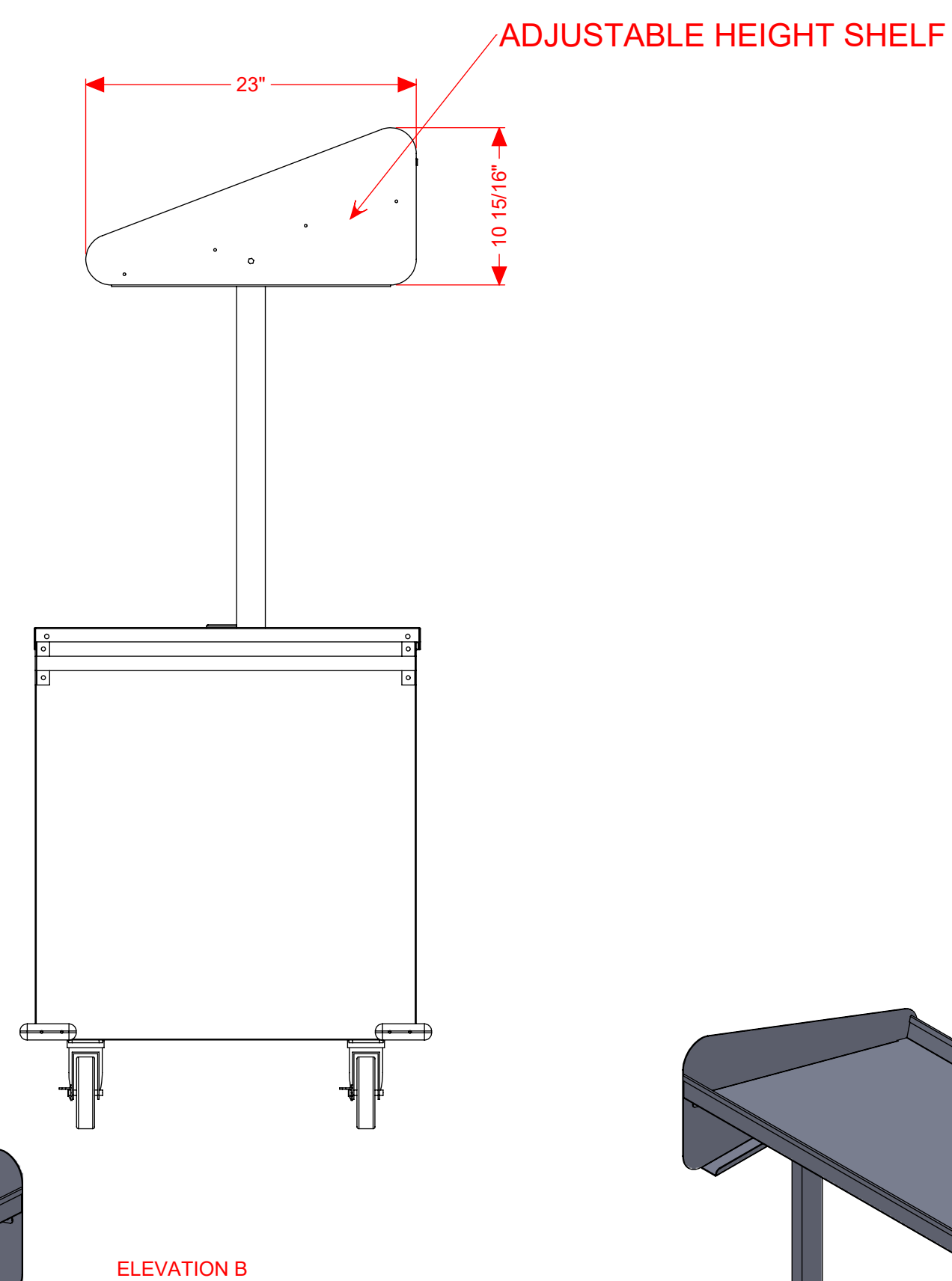

ELEVATION B

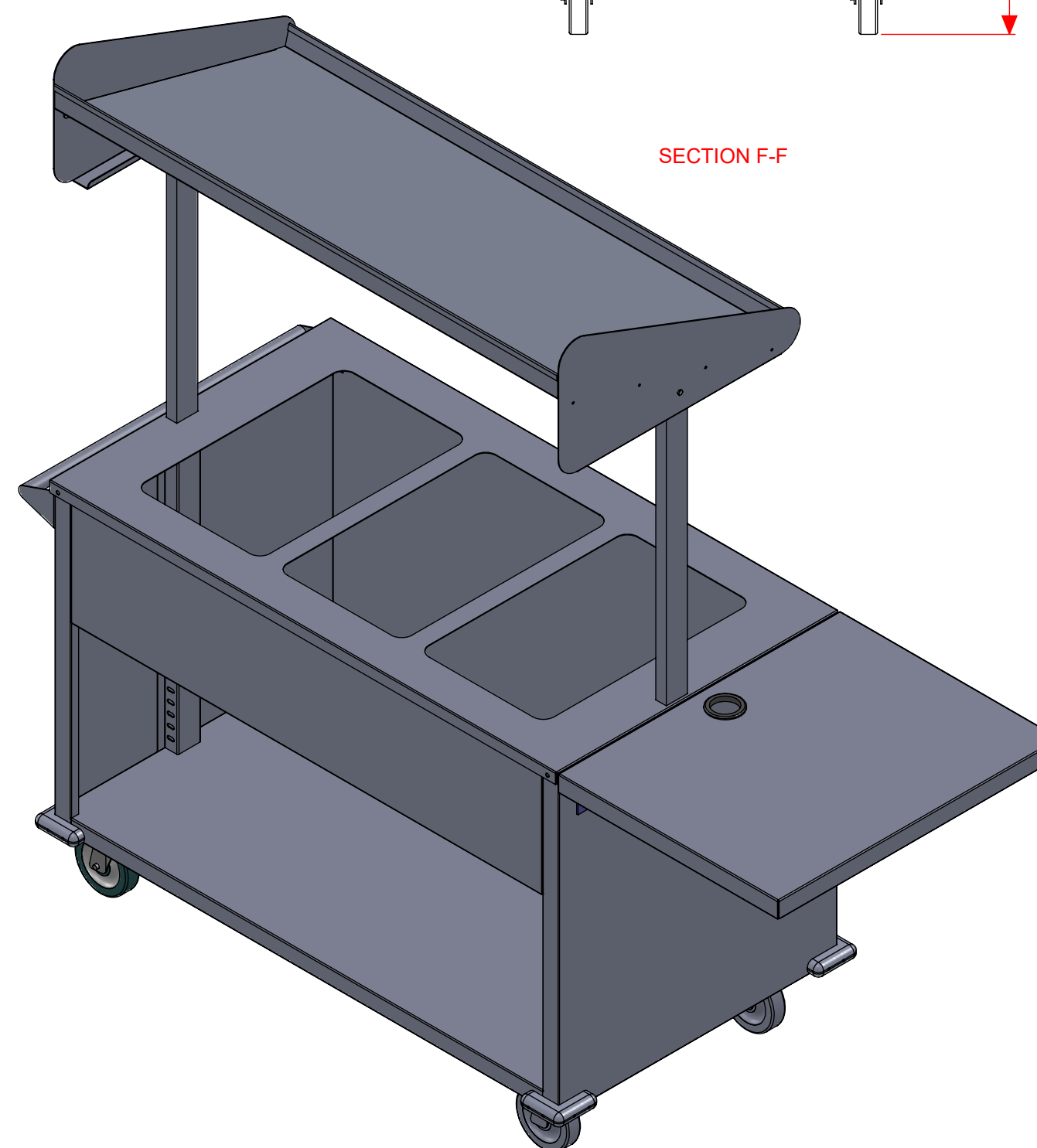
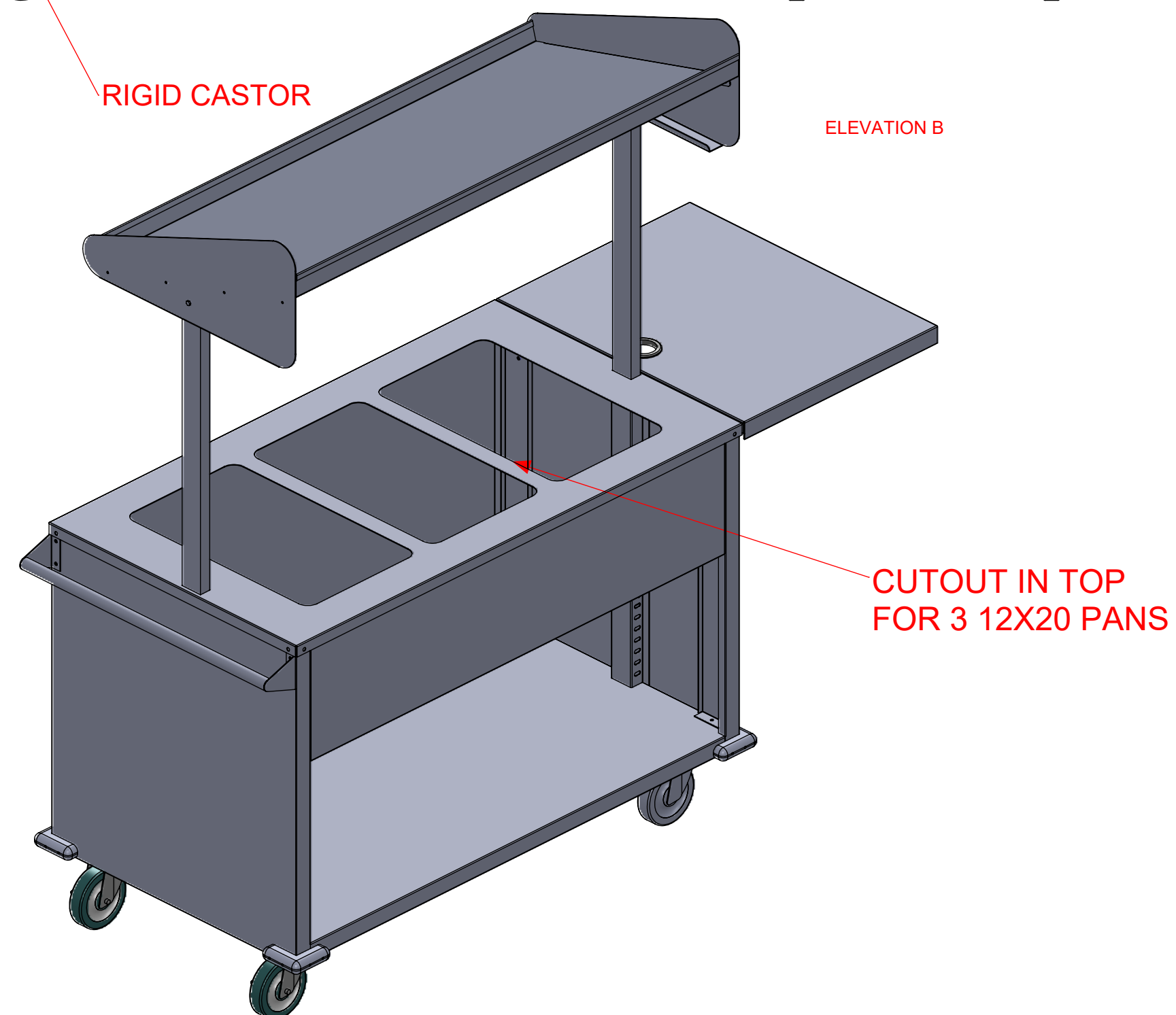

SECTION F-F

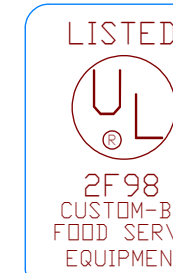

1 Foodservice equipment manufactured by American Foodservice Company is built in accordance with the latest requirements and standards of NSF International (sanitation) and Underwriters Laboratories (safety).  
2 In the event a state or local code requirement exceeds those of NSF International and/or Underwriters Laboratories, failure to notify American Foodservice Company in advance of production and in writing, may result in the equipment failing to pass local inspection(s) and/or additional charges for making modifications to the equipment.

◇ GENERAL NOTES:

○ COMPONENTS

	MANUFACTURER, PART#, AND DESCRIPTION	AFC PART #	SUPPLIED BY:	INSTALLED BY:
①	2 CHG RIDIG CASTER	043302	SIS	SIS
②	2 CHG CASTER/WITH BRAKE	043301	SIS	SIS
③	3 CHG Q24-0520 2.5" DIA GROMMET	623080	SIS	SIS
④	3 CHG J19-4967 FOLD DOWN TRAY RAIL BRACKET	042628	SIS	SIS
⑤	4 CORNER BUMPTER		SIS	SIS
⑥			SIS	SIS
⑦			SIS	SIS
⑧			SIS	SIS
⑨			SIS	SIS
⑩			SIS	SIS
⑪			SIS	SIS
⑫			SIS	SIS
⑬			SIS	SIS
⑭				
⑮				
⑯				
⑰				
⑱				
⑲				
⑳				
㉑				
㉒				
㉓				
㉔				
㉕				
㉖				
㉗				

FINISH SCHEDULE:

SSL = STAINLESS STEEL LAMINATE	PLY = Plywood	S/S = Stainless Steel	BRK = Brick
PLL = PLASTIC LAMINATE	WOOD = Wood	STL = Steel	CVB = Cove Base
MMS = Man Made Stone	STA = Stain	GLV = Galvanized Metal	M/D = Molding
STN = Stone	PNT = Paint	ALU = Aluminum	GLS = Glass
SLS = Solid Surface	TLE = Tile	SND = Sound Deadener	INS = Insulation
CTB = Cutting Board			

①	14 GA 304 S/S
②	16 GA 304 S/S
③	18 GA 304 S/S
④	20 GA 304 S/S
⑤	1" OD S/S TUBE
⑥	
⑦	
⑧	
⑨	
⑩	
⑪	
⑫	
⑬	
⑭	
⑮	
⑯	
⑰	
⑱	
⑲	
⑳	

CUSTOMER APPROVAL

APPROVED BY: \_\_\_\_\_ DATE: \_\_\_\_\_

APPROVED AS NOTED: \_\_\_\_\_ DATE: \_\_\_\_\_

REVISE & RESUBMIT: \_\_\_\_\_ DATE: \_\_\_\_\_

AFC APPROVAL

APPROVED BY: \_\_\_\_\_ DATE: \_\_\_\_\_

REVISIONS

△	DATE	REV. BY:	CHECKED BY:	DESCRIPTION
△				

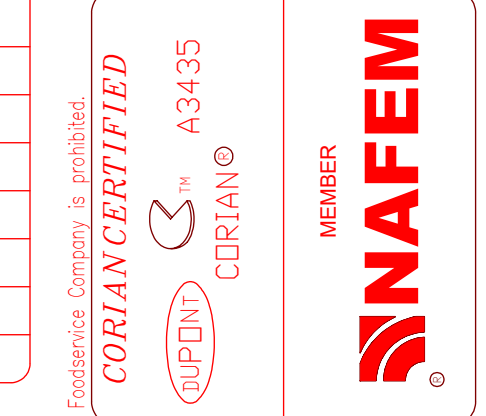

The confidential drawing is the property of American Foodservice Company. Reproduction and/or distribution without the expressed written consent of American Foodservice Company is prohibited.

PROJECT NAME & LOCATION:

ITEM DESCRIPTION: **BREAKFAST CART WITH OVERSHELF**

DATE: \_\_\_\_\_

SCALE: 3/4" = 1'0"

DRAWN BY: RVB

CHECKED BY: \_\_\_\_\_

SUBMITTED BY: \_\_\_\_\_

PROJECT/PRODUCT#: \_\_\_\_\_

BC-ASY

SHEET NO. S1 of 1