

KRATOS

HEATED CABINET MANUAL



28W-152
28W-153
28W-154
28W-155



Central Restaurant Products®

7750 Georgetown Road • Indianapolis, IN 46268

800.222.5107 • www.centralrestaurant.com

HEATED CABINET MANUAL

Thank you for choosing to purchase from Kratos. Every Kratos product is manufactured with the customer in mind by providing the best value without sacrificing quality. The Kratos heater-proofer is an aluminum transport cabinet with heaters to function as a hot food holding cabinet, and/or as a proofing cabinet.

TABLE OF **Contents**

03 RECEIVING INSTRUCTIONS

04 WARNINGS

05 PARTS VIEWS

14 OPERATING INSTRUCTIONS

16 CLEANING INSTRUCTIONS

17 ELECTRIC CIRCUIT

18 WARRANTY INFORMATION

HEATED CABINET MANUAL

Receiving & Inspecting EQUIPMENT

Care must be taken during unloading so the equipment is not damaged while being moved into the building.

1. Visually inspect the exterior of the package. Note any damage and report it to the delivering carrier immediately.
2. If damaged, open and inspect the contents with the carrier.
3. In the event that there is concealed damage upon opening, notify the carrier. Notification should be made verbally as well as in written form.
4. Request an inspection by the shipping company of the damaged equipment. This should be done within 10 days from receipt of the equipment.
5. Freight carriers can supply the necessary damage forms upon request.
7. Retain all crating material until an inspection has been made or waived.

HEATED CABINET MANUAL

Warnings & Cautions



WARNING



Follow all food safety guidelines. Pre-heat the cabinet to the desired temperature before placing cooked, hot food into the cabinet. This is not a re-thermalizing cabinet. Food must be at the appropriate temperature before being placed in this cabinet. Use a food probe to check internal food temperature—the cabinet temperature is not necessarily the internal food temperature.

WARNING



Only factory approved service agents should attempt to service, repair, or replace electrical components, wiring, or power cord.

WARNING



This cabinet is for hot food holding applications only.

WARNING



Unplug the cabinet before cleaning or servicing. Do not wash the cabinet with a water jet or high pressure water.

CAUTION



Do not spray or pour water into the module. To clean the cabinet, wip with a damp cloth and dry with a towel. Use only cleaning agents approved for aluminum.

CAUTION



Water dripping onto the floor from open doors can be a slip hazard.

HEATED CABINET MANUAL

EXPLODED
VIEWS

Parts

Heated Cabinet — Drawers

DRAWERS

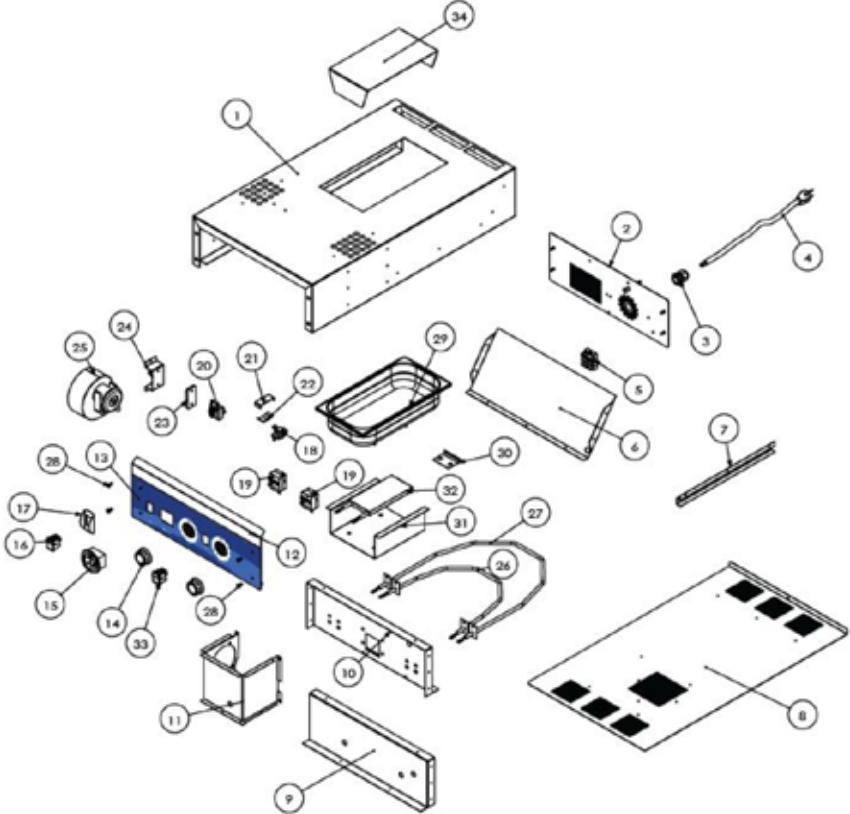

HEATED CABINET MANUAL

Replacement PARTS

Heated Cabinet — Drawers

DRAWER

Drawer Replacement Parts

No.	Photo	Part No.	Part Description	HCD1500 Qty	HCD1500H Qty
03		HCD-030	Cable Bushing	1	1
04		HCD-031	Power Cable	1	1
05		HCD-026	Terminal Block	1	1
14		HCD-035	Knob	2	1
15		HCD-024	Thermometer	1	1
16		HCD-016	Main Switch with light Red	1	1
18		HCD-019	Limit Temp. Thermostat	1	1
19		HCD-034	Temp. Thermostat	2	1
20		HCD-017	Transformer	1	1
25		HCD-012	Blower and Motor Assembly	1	1
27		HCD-011	Heating element 900W	1	1
28		HCD-010	Heating element 600W	1	1
29		HCD-008	SS Water Pan	1	N/A
32		HCD-009	Heating element 600W	1	N/A
33		HCD-036	Switch Heat/Proof Red	1	N/A

HEATED CABINET MANUAL

EXPLODED VIEWS

Parts

Heated Cabinet — Cabinet

CABINET

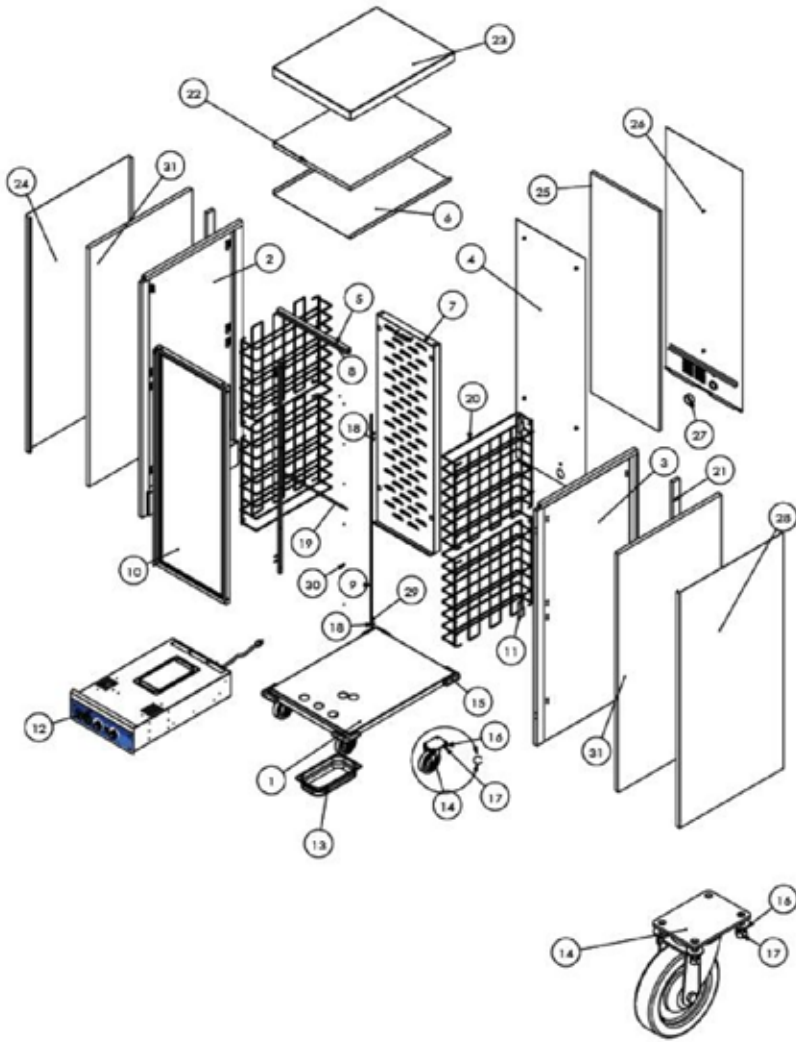

HEATED CABINET MANUAL

EXPLODED VIEWS

Parts

Heated Cabinet — Cabinet

CABINET

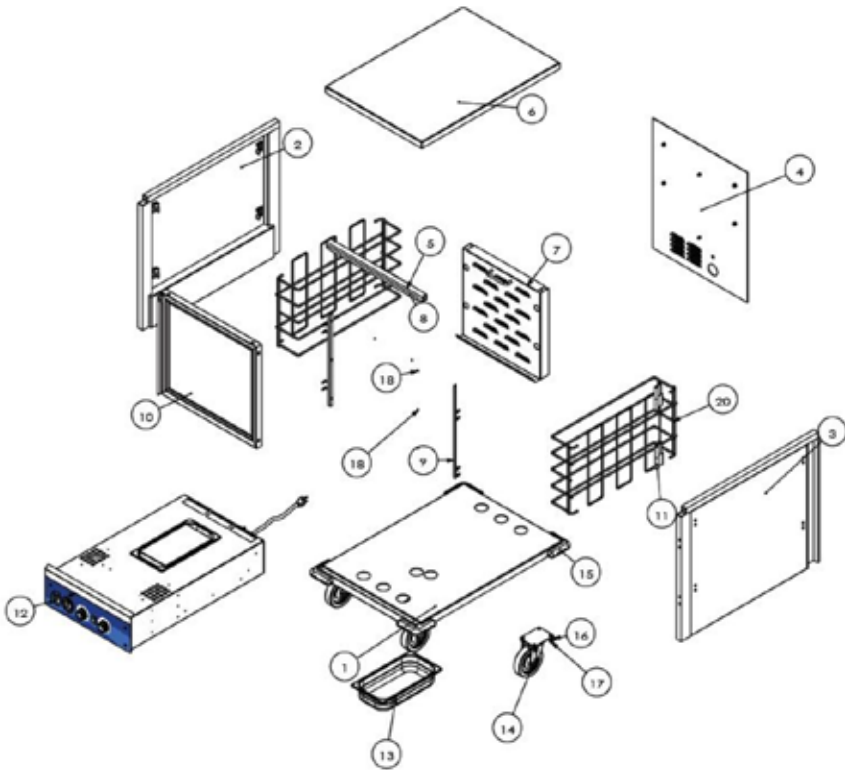

HEATED CABINET MANUAL

Operating INSTRUCTIONS

Heated Cabinet

PROOFING INSTRUCTIONS

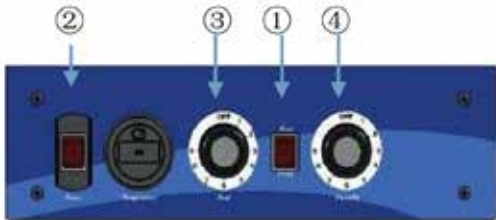

- 1) Set Combination Module switch to PROOF
- 2) Set POWER switch to the ON position. Power indicator light.
- 3) Set TEMPERATURE control to 2.
- 4) Set HUMIDITY control to 9.
- 5) Pre-heat cabinet until desired temperature and humidity is reached (typical heat-up time from 77°(25°C) ambient to 95°(35°C) and 95% relative humidity is approximately 30 minutes).
- 6) Adjust settings as necessary to reach desired temperature and humidity levels.

NOTE: The internal air circulation blower and 1500w heater element (controlled with the Heat Thermostat) will operate continuously when the power switch is turned ON.

HEAT THERMOSTAT

The controlling range is 80°F to 185°F. The dial numbers, 1 thru 9, do not relate to a specific calibrated temperature. Temperature settings must be obtained through familiarization with the unit. The dial also has an OFF position to turn heater unit off.

HUMIDITY THERMOSTAT

To control humidity range from 30% to 100%, humidity settings must be obtained through familiarization with the unit. The dial numbers, 1 thru 9, do not relate to a specific calibrated humidity. The dial also has an OFF position to turn humidity off.

To maintain low heat range between 85°F to 100°F, switch to proof mode and adjust heat knob to desired heat range. Allow 45 minutes to pre-heat in proof cycle.

HEATED CABINET MANUAL

Operating INSTRUCTIONS

Heated Cabinet

BASIC CABINET SETUP

- A. Refer to DATA PLATE for electrical requirements. Cabinets rated at 120V 1500 watts must be plugged into a 125 VAC 15 amp receptacle and must be used on an individual branch circuit. DO NOT MODIFY CORD PLUG.
- B. With POWER switch OFF, plug into 125 VAC grounded receptacle.
- C. Fill water pan to top with clean HOT tap water for Proofing or if moisture is desired for Holding. Check water level every 3 hours (2 hours when Proofing) and refill with clean HOT tap water as necessary. Water pan does not have to be filled for Heating. Proofing requires water pan to be filled.

HEATING INSTRUCTIONS

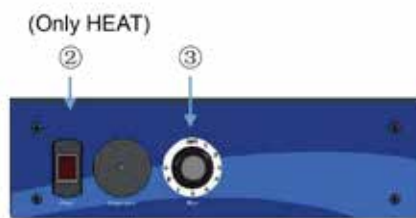
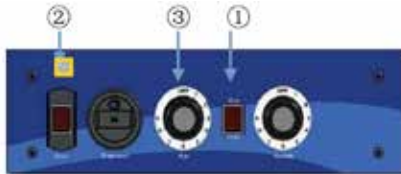

- 1) Set Combination Module switch to HEAT
- 2) Set POWER switch to the ON position. Power indicator light.
- 3) Set TEMPERATURE control to 9.
- 4) Pre-heat cabinet until desired temperature is reached (typical heat-up time from 77°(25°C) ambient to 160°(71°C) is approximately 45 minutes). Cabinet with insulate temperature is reached 185°(85°C) approximately 45 minutes.
- 5) Re-set TEMPERATURE control and adjust as necessary to reach desired temperature (setting 6-8 is typical for 150°(66°) to 160°(71°C)).

HEATED CABINET MANUAL

Cleaning INSTRUCTIONS

The equipment has been designed to require minimum maintenance and has been constructed to meet National Sanitation Foundation and U.S. Public Health Service standards. Non-toxic chemical cleaners or mild detergents are recommended for cleaning of fixtures. DO NOT use steel wools of any kind. Steel wool particles will work into the grains of the metal causing corrosion. Also, these particles can cause a health hazard. If scouring is required, use a non-abrasive type of cleaner. Do not use caustic solutions on your equipment. Hosing or steam cleaning should not be necessary keep these fixtures clean and sanitary. Do not allow water or steam to come into contact with electrical components. Never Power wash or steam clean the cabinet with the power drawer inserted.

CAUTION

Be sure to disconnect power source before cleaning and servicing the unit. Liability for improper or careless use is the responsibility of the equipment owner or persons servicing the unit, including the authorized service agent.

HEATED CABINET MANUAL

Electric CIRCUIT

Heated Cabinet

ELECTRIC SCHEMATIC POWER SUPPLY

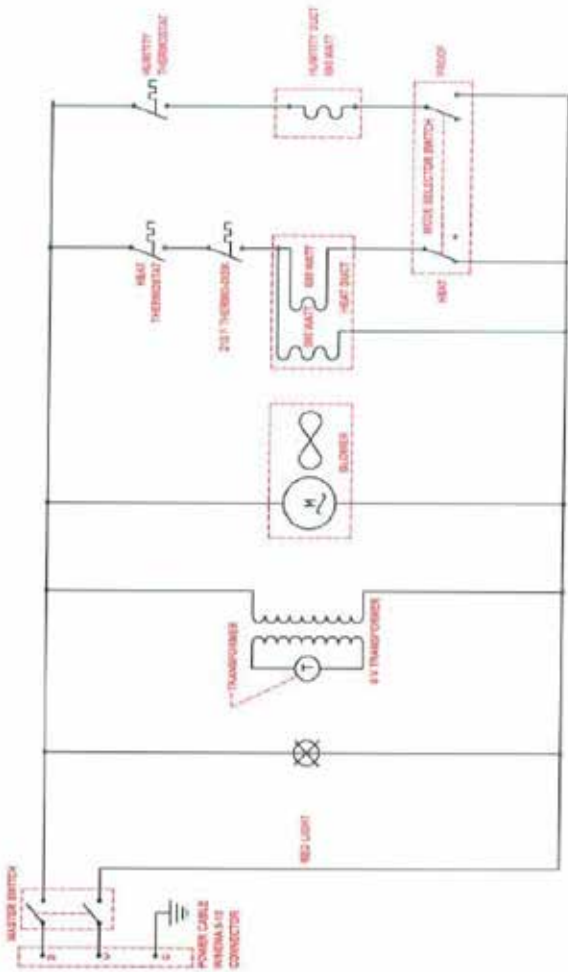

HEATED CABINET MANUAL

Warranty INFORMATION

One-Year Limited Warranty

Kratos offers a one-year warranty to the original purchaser of new equipment. The unit will be free of defects in material and workmanship for a period of 1 year from the date of delivery. Warranty is not transferrable. Kratos, at its own discretion, will provide replacement components, replace the entire unit, or refund the purchase price to satisfy the warranty obligation. Kratos makes no other warranties, express or implied, statutory or otherwise, and hereby disclaims all implied warranties, including the implied warranties of merchantability and of fitness for a particular purpose.

The one-year limited warranty does not cover:

- Failure to install and/or use equipment within proper operating conditions as specified by Kratos.
- Outdoor use will void the warranty. The finish is not guaranteed in mobile applications where the table can be damaged due to improper securement.
- Products that have been modified, abused, or misused. Any products that have been exposed to corrosive or other cleaners not intended for use on stainless steel will void the warranty.
- Any products sold outside the continental United States.
- Any products where the original sale cannot be determined. No order number, invoice, or receipt to provide proof of purchase will void any warranty coverage.
- Labor or service not authorized by Kratos is not covered under this warranty.
- Freight damage must be reported at the time of delivery and addressed with the carrier for compensation.
- Kratos will not be liable for any parties that experience loss of product, consequential damage, lost business or any other expenses.
- Defects, or damage due to improper maintenance, wear and tear, abuse, misuse, vandalism, or natural disasters.

For Warranty Inquiries

To obtain warranty information or make a claim against this warranty, please contact the location where you purchased the product.

If purchased on www.centralrestaurant.com, **call 800-215-9293 or email**