

# **CENPRO**

## **INSULATED FOOD PAN CARRIER AND BEVERAGE DISPENSER MANUAL**



**Central Restaurant Products®**

7750 Georgetown Road • Indianapolis, IN 46268

800.222.5107 • [www.centralrestaurant.com](http://www.centralrestaurant.com)

# INSULATED FOOD PAN CARRIER & BEVERAGE DISPENSER MANUAL

Thank you for choosing to purchase from CenPro. We design every CenPro product with the customer in mind. Our goal is to provide our customers the best value for all their storage and transport needs. CenPro stainless steel utility carts are NSF approved so you can have the peace of mind they will meet your location's needs. These carts are made of durable stainless steel material and are easy to assemble so you can get to work right away. Be sure to check out [www.centralrestaurant.com](http://www.centralrestaurant.com) for the full line of CenPro products.

## TABLE OF **Contents**

**03 RECEIVING** INSTRUCTIONS

---

**04 OPERATION** INSTRUCTIONS

---

**05 CLEANING** INSTRUCTIONS

---

**06 ASSEMBLY** INSTRUCTIONS

---

**07 WARRANTY** INFORMATION

---

# INSULATED FOOD PAN CARRIER & BEVERAGE DISPENSER MANUAL

## Receiving & Inspecting EQUIPMENT

Care must be taken during unloading so the equipment is not damaged while being moved into the building.

1. Visually inspect the exterior of the package. Any damage should be noted and reported to the delivering carrier immediately.
2. If damaged, open and inspect the contents with the carrier.
3. In the event that the exterior is not damaged, yet upon opening, there is concealed damage to the equipment, notify the carrier. Notification should be made verbally as well as in written form.
4. Request an inspection by the shipping company of the damaged equipment. This should be done within 10 days from receipt of the equipment.
5. Freight carriers can supply the necessary damage forms upon request.
6. Retain all crating material until an inspection has been made or waived.

# INSULATED FOOD PAN CARRIER & BEVERAGE DISPENSER MANUAL

## Operation INSTRUCTIONS

### Insulated Food Pan Carrier & Beverage Dispenser

1. Wash and rinse the interior/exterior before using each time.
2. If serving hot beverages in the dispenser, filling the unit with hot water first will help to improve heat retention.
3. If serving cold beverages in the dispenser, filling the unit with cold water first will help to improve cold retention.
4. Check to make sure all gaskets are in place. Fill the container to maximum capacity and lock the lid in place.
5. Frequent opening of the lid will have a negative impact on temperature retention.
6. **WARNING** Liquids can overflow or come out of the top vent cap if the unit is overfilled.  
**DO NOT FILL HIGHER THAN 1.25" FROM THE TOP OF THE UNIT.**

# INSULATED FOOD PAN CARRIER & BEVERAGE DISPENSER MANUAL

## Cleaning INSTRUCTIONS

1. Clean each unit with a sponge or cloth along with mild detergent and sanitizing solution. For the food pan carrier, use of a brush is okay to remove food or debris from the interior. Wipe the unit dry with a cloth and store in cool, dry area.
2. Unscrew the union nut which will allow the faucet to be removed from the unit
3. Unscrew the bonnet from the faucet to reveal the rubber seat cup and stem. Remove the seat cup.
4. Push back the union nut and remove the metal "C" ring. Unscrew wing nut to remove spout. Be careful not to lose small parts.
5. Push the lever down to the locked position to clean the top of the bonnet.
6. Clean all parts of the faucet with a cleaning solution. Use a faucet brush to clean the insides of the faucet and spout.

# INSULATED FOOD PAN CARRIER & BEVERAGE DISPENSER MANUAL

## Assembly INSTRUCTIONS

### Faucet

1. Place the small rubber washer on the spout and place the spout inside the unit.
2. Place the large washer on the spout from the outside of the unit.
3. Screw the wing nut on spout and fit the union nut on the spot. Replace the metal "C" ring.
4. Replace the rubber seat cup on the spring and stem end of the faucet.
5. Apply pressure to secure the seat cup and screw the bonnet on to the faucet body.
6. Screw Faucet onto the spout and tighten union nut.

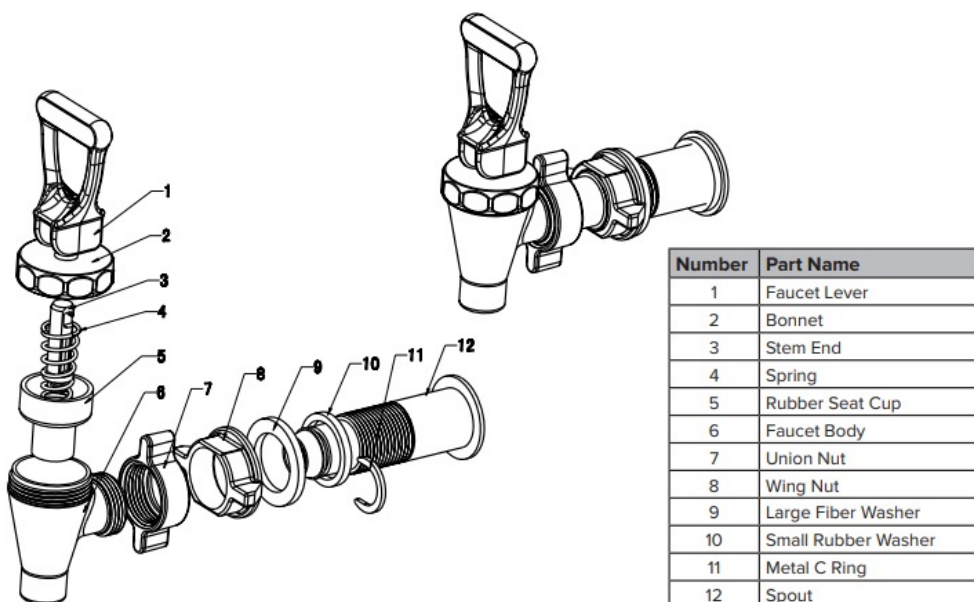

# INSULATED FOOD PAN CARRIER & BEVERAGE DISPENSER MANUAL

## Warranty INFORMATION

### 90 Day Limited Warranty

CenPro offers a 90 day warranty to the original purchaser of new equipment, the model of equipment will be free of defects in material and workmanship for a period of 90 days from the date of delivery. Warranty is not transferrable. CenPro, at its own discretion, will provide replacement components, replace the entire unit or refund the purchase price to satisfy the warranty obligation.

The 90 day limited warranty does not cover:

- Failure to install and/or use equipment within proper operating conditions as specified by CenPro.
- Outdoor use will void the warranty. The finish is not guaranteed in mobile applications where the table can be damaged due to not being secured to the floor.
- Products that have been modified, abused, or misused. Any products that have been exposed to corrosive or other cleaners not intended for use on aluminum will void the warranty.
- Any products sold outside the contiguous United States.
- Any products where the original sale cannot be determined. No order #, invoice or receipt to provide proof of purchase will result in no warranty coverage.
- Labor or service not authorized by CenPro is not covered under this warranty.
- Freight damage must be made at time of delivery and addressed with the carrier for compensation.
- CenPro will not be liable for any parties that experience loss of product, consequential damage, lost business or any other expenses.

#### For Warranty Inquiries

To obtain warranty information or make a claim against this warranty, please contact the location where you purchased the product.

If purchased on [www.centralrestaurant.com](http://www.centralrestaurant.com), **call 800-215-9293** or email **[sales@centralrestaurant.com](mailto:sales@centralrestaurant.com)**.