

KRATOS

CONVECTION OVEN

MANUAL



29M-001
29M-002
29M-003

Central Restaurant Products®

7750 Georgetown Road • Indianapolis, IN 46268

800.222.5107 • www.centralrestaurant.com

CONVECTION OVEN MANUAL

Thank you for choosing to purchase from Kratos. Every Kratos product is manufactured with the customer in mind by providing the best value without sacrificing quality. Kratos Convection Ovens are ETL-certified to meet key sanitation needs.

TABLE OF **Contents**

03 RECEIVING INSTRUCTIONS

04 SAFETY INFORMATION

05 EXTERIOR DIAGRAM

06 SPECIFICATIONS

07 OPERATION INSTRUCTIONS

08 CLEANING INSTRUCTIONS

09 TROUBLESHOOTING INSTRUCTIONS

10 PARTS VIEW & LIST

12 WARRANTY INFORMATION

CONVECTION OVEN MANUAL

Receiving & Inspecting EQUIPMENT

Care must be taken during unloading so the equipment is not damaged while being moved into the building.

1. Visually inspect the exterior of the package. Note any damage and report it to the delivering carrier immediately.
2. If damaged, open and inspect the contents with the carrier.
3. In the event that there is concealed damage upon opening, notify the carrier. Notification should be made verbally as well as in written form.
4. Request an inspection by the shipping company of the damaged equipment. This should be done within 10 days from receipt of the equipment.
5. Freight carriers can supply the necessary damage forms upon request.
7. Retain all crating material until an inspection has been made or waived.

CONVECTION OVEN MANUAL

Safety Information

Save these instructions and always follow safety guidelines when operating electrical equipment.

1. Read and understand all instructions before operating this equipment.
2. These convection ovens are for commercial purposes only.
3. Keep all cords, plugs, and other electrical components away from liquids to prevent electrical shock.
4. Never touch the hot surfaces while in use.
5. Unplug the oven when not in use and before cleaning.
6. Do not operate the convection oven with any noticeable damage or malfunctions to the oven, cord and plug.
7. Designed for indoor use only, do not use outdoors.
8. Ensure your outlet and voltage is correct for the plug type
9. Before unplugging the unit, turn the timer and temperature knobs both to the "OFF" position.
10. Never place metal utensils or oversized foods inside the cabinet that could lead to electrical shock or fire.
11. Do not store anything on top of the oven.
12. Keep clear of all flammable materials during operation.
13. Do not clean with metal scouring pads which will shorten the life of the unit and increase electrical shock risks.
14. Do not place materials such as paper, cardboard, plastic, etc. in this oven.
15. Avoid scratching the tempered glass door which will affect the unit's heat retention
16. Use of accessories not recommended by the manufacturer may result in injury or damage to the unit.
17. Only trained adults should operate this unit and any children nearby need supervised.
18. This appliance is not intended for use by anyone with reduced physical sensory or mental capabilities, or lack of experience and knowledge, unless they have been given supervision or instruction concerning use of the appliance by a person responsible for their safety.
19. Ensure the unit is on a flat surface that is well ventilated. The appliances should ALWAYS be supervised during operation. DO NOT leave the appliance unattended without powering off.

CONVECTION OVEN MANUAL

Exterior Diagram

And Key Components

1. Handle
2. Door assembly
3. Timer
4. Power light
5. Heating light
6. Thermostat
7. Foot
8. Shell

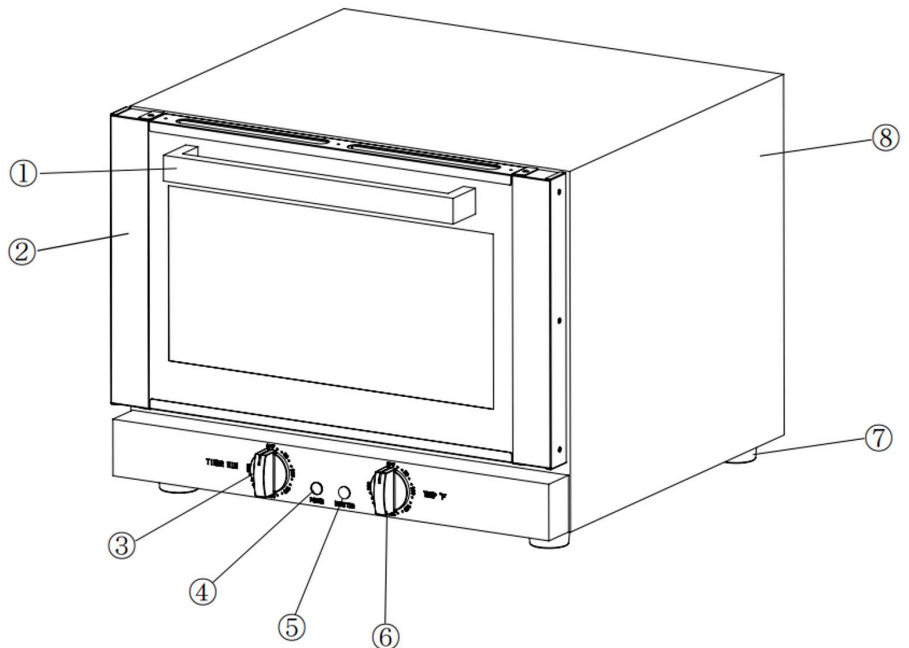

Accessories

Roasting Racks

29M-020- replacement rack for 29M-001
quarter size convection oven

29M-021- replacement rack for 29M-002 and

29M-003 half size convection ovens

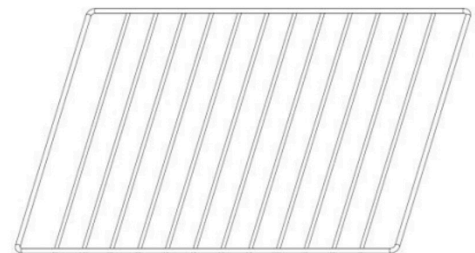

CONVECTION OVEN MANUAL

Specifications

Convection Ovens

MODEL NO.	VOLTAGE/POWER	DIMENSIONS	UNIT WEIGHT	PLUG
29M-001	120V/60Hz/1440W	W18.7"xD19.8"xH15.0"	32.4lbs	ETL
29M-002	120V/60Hz/1600W	W22.8"xD22.4"xH16.0"	43.4lbs	ETL
29M-003	208-240V/60Hz/2800W	W22.8"xD22.4"xH20.1"	52.0lbs	ETL

BEFORE USING YOUR OVEN

Before using your oven for the first time, please note these instructions:

1. The oven is not to be installed closer than 12" to a combustible surface and needs kept 4" distance from wall.
2. Wash the roasting racks with soap and water. (NOTE: Do not use a spray or abrasive polishing agent.)
3. Gently wipe down interior cabinet with a damp cloth. Be careful not to add excess water or get soap/water on the element
4. After the cabinet and racks are dry, place the racks back inside the oven.
5. Close the oven door and allow it to preheat at the highest temperature setting for 5 minutes.
6. The heating element is lubricating and will burn off extra grease at first use. It is normal to see a small amount of smoke.
7. Turn off the oven then and open the door to allow any smoke to leave the cabinet.

CONVECTION OVEN MANUAL

Operation INSTRUCTIONS

Convection Ovens

OPERATION

To start your oven, you first select the desired cooking temperature then the desired cook time. Oven will then begin heating.

CAUTION: During the baking process, make sure that no metal comes in contact with the electric heating elements.

CAUTION: Wear oven mitts when dealing with any product inside the oven.

1. Plug in your oven
2. Adjust temperature control knob to desired cooking temperature.
3. Temperature indicator light will shut off once desired temperature has been reached.
4. Load product into the oven
5. Set timer between 0-120 minutes
 - a. The timer is independent and can be adjusted during cooking cycle
6. Timer reaches zero and timer chimes
7. Unload the oven using oven mitts.
8. If more time is needed, follow the steps again to continue baking.

Overheating protection

If the temperature of this oven reaches an unsafe limit, the electrical components will shut off to prevent overheating and damage to components.

CONVECTION OVEN MANUAL

Cleaning INSTRUCTIONS

Convection Ovens

Cleaning & Maintaining Your Oven

1. Unplug the unit and allow it to cool
2. Wash the roasting racks with soap and water. (NOTE: Do not use a spray or abrasive polishing agent.)
3. Gently wipe down interior cabinet with a damp cloth. Be careful not to add excess water or get soap/water on the element
4. After the cabinet and racks are dry, place the racks back inside the oven.

CONVECTION OVEN MANUAL

Troubleshooting

INSTRUCTIONS

Convection Ovens

Troubleshooting

Problem: The oven does not become hot after being switched on.

- Be sure that the timer switch is set.
- Be sure that the temperature control knob is set.

Problem: There is a metallic sound when the oven is in use.

- Do not attempt to dismantle the oven.
- Contact your service agent right away to examine the fan.

Problem: Food is often overcooked or burned, even when cooked according to the recipe.

- Check that the fan motor is operating normally.
- Contact your service agent to examine the temperature control knob.

CONVECTION OVEN

MANUAL

Parts

VIEW & LIST

Convection
Ovens

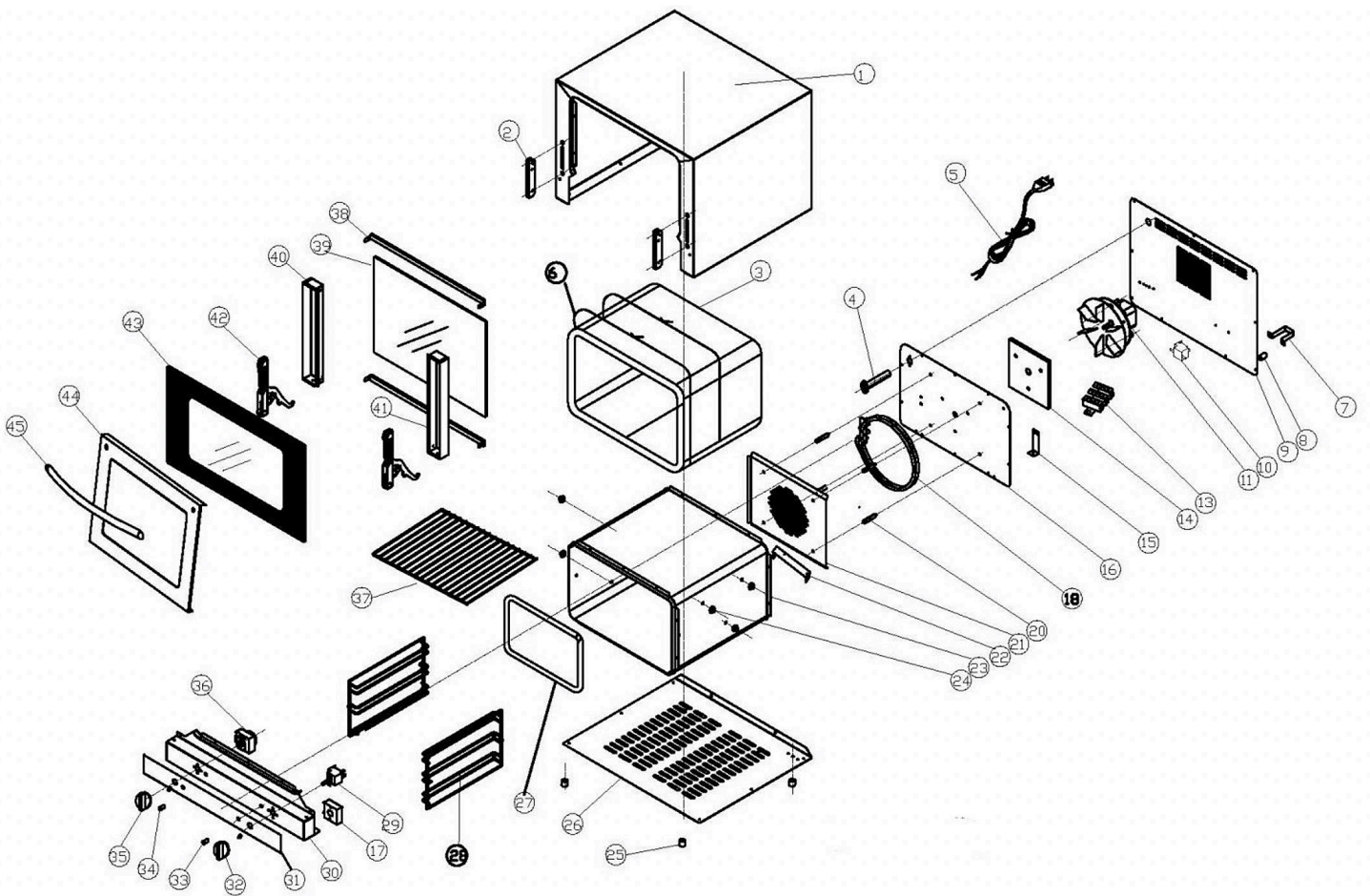

CONVECTION OVEN MANUAL

Parts

VIEW & LIST

Convection Ovens

NO PART NAME

- 1 Shell
- 2 Hinge wheel
- 3 Insulation
- 4 Exhaust pipe
- 5 Power cord
- 6 Wire for insulation
- 7 Space holder
- 8 Wire buckle
- 9 Rear board
- 10 Temperature limiter
- 11 Fully Fan motor assembly
- 13 Terminalblock
- 14 Motor insulation
- 15 Connection plate
- 16 Middle board
- 17 Functional switch
- 18 Heating element
- 20 Connection pole
- 21 Fan cover
- 22 Sensor bracket
- 23 Interior
- 24 Screws for grid assembling

NO PART NAME

- 25 Foot
- 26 Bottom board
- 27 Door gasket
- 28 Tray grid
- 29 Thermostat
- 30 Control box
- 31 Control panel
- 32 Thermostat knob
- 33 Heating light
- 34 Power light
- 35 Timer knob
- 36 Timer
- 37 Baking tray
- 38 Upper and lower door clip
- 39 Inner glass
- 40 Left door frame
- 41 Right door frame
- 42 Hinge assembly
- 43 Outer glass
- 44 Front door frame
- 45 Handle

CONVECTION OVEN MANUAL

Warranty INFORMATION

One-Year Limited Warranty

Kratos offers a one-year warranty to the original purchaser of new equipment. The unit will be free of defects in material and workmanship for a period of 1 year from the date of delivery. Warranty is not transferrable. Kratos, at its own discretion, will provide replacement components, replace the entire unit, or refund the purchase price to satisfy the warranty obligation. Kratos makes no other warranties, express or implied, statutory or otherwise, and hereby disclaims all implied warranties, including the implied warranties of merchantability and of fitness for a particular purpose.

The one-year limited warranty does not cover:

- Failure to install and/or use equipment within proper operating conditions as specified by Kratos.
- Outdoor use will void the warranty. The finish is not guaranteed in mobile applications where the oven can be damaged due to improper securement.
- Products that have been modified, abused, or misused. Any products that have been exposed to corrosive or other cleaners not intended for use on stainless steel will void the warranty.
- Any products sold outside the continental United States.
- Any products where the original sale cannot be determined. No order number, invoice, or receipt to provide proof of purchase will void any warranty coverage.
- Labor or service not authorized by Kratos is not covered under this warranty.
- Freight damage must be reported at the time of delivery and addressed with the carrier for compensation.
- Kratos will not be liable for any parties that experience loss of product, consequential damage, lost business or any other expenses.
- Defects, or damage due to improper maintenance, wear and tear, abuse, misuse, vandalism, or natural disasters.

For Warranty Inquiries

To obtain warranty information or make a claim against this warranty, please contact the location where you purchased the product.

If purchased on www.centralrestaurant.com, call **800-215-9293** or email **sales@restaurant.com**.