

KRATOS

PROJECT NAME: _____
 LOCATION: _____
 ITEM #: _____ QTY: _____
 MODEL: _____

16 GAUGE STAINLESS STEEL COMPARTMENT SINKS



29N-008-LT

29N-001

29N-008-RT

SPECIFICATIONS

ITEM	29N-001	29N-002	29N-008-LT	29N-008-RT
BOWLS	3	3	1	1
WIDTH	87"	90"	40"	40"
DEPTH	25.5"	24"	23.5"	23.5"
HEIGHT	44.5"	44.5"	45.5"	45.5"
WORK SURFACE HEIGHT	35.25"	35.25"	35.25"	35.25"
STAINLESS STEEL TYPE	304	304	304	304
GAUGE	16	16	16	16
BOWL SIZE W" X L" X H"	16x20x14	18x18x14	18x18x12	18x18x12
BACKSPLASH HEIGHT	10"	10"	10"	10"
DRAINBOARDS	2	2	1	1
SINK WEIGHT	135 LBS.	140 LBS.	57 LBS.	57 LBS.

FEATURES

- MADE OF HIGH QUALITY 16 GAUGE 304 STAINLESS STEEL
- STURDY STAINLESS STEEL LEGS WITH BULLET FEET
- CROSS BRACES ON LEGS PROVIDE MAXIMUM STABILITY
- ROLLED EDGES & BACKSPLASH KEEP WATER OFF OF THE FLOOR
- 10" BACKSPLASH
- 18" DRAINBOARD(S) OFFER CONVENIENT STORAGE
- COMES WITH 1.5" IPS DRAIN CONNECTION & 3 1/2" BASKET STRAINER(S)
- FAUCETS SOLD SEPARATELY
- NSF CERTIFIED

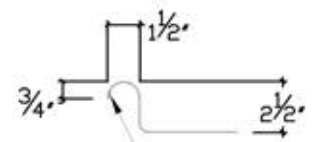
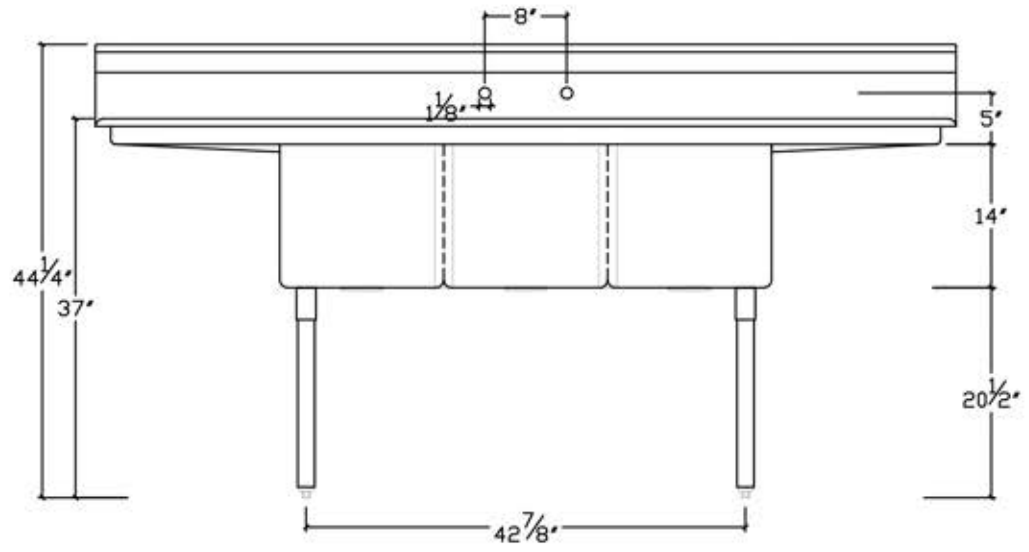
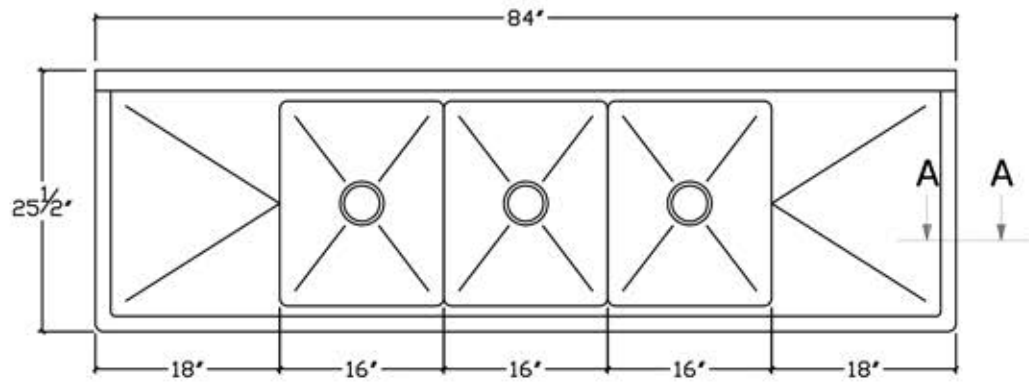

CLOSED HEM
(TO INSIDE OF SINK)

SECTION A-A

- GENERAL NOTES**
- * TOP - 16 GA. 304 S/S #3 POL.
 - * LEGS - 16 GA. 1-5/8 DIA. S/S TUBING.
 - * FEET - S/S ADJUSTABLE FEET.
 - * ALL SEAMS WELDED & POLISHED
 - * NO BURRS OR SHARP EDGES
 - * MEETS NSF STD. 2
- FEATURES**
- * 9 3/4" BACK SPLASH.
 - * 3 1/2" DRAIN BASKET INCLUDED.

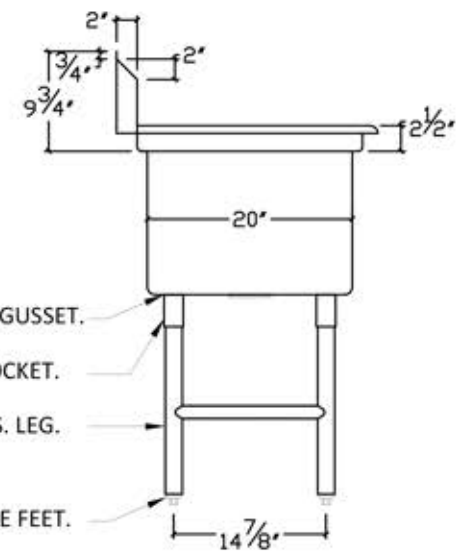

STAINLESS STEEL COMPARTMENT SINKS

29N-001
ITEM NUMBER



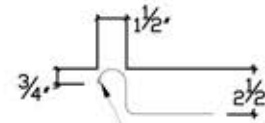
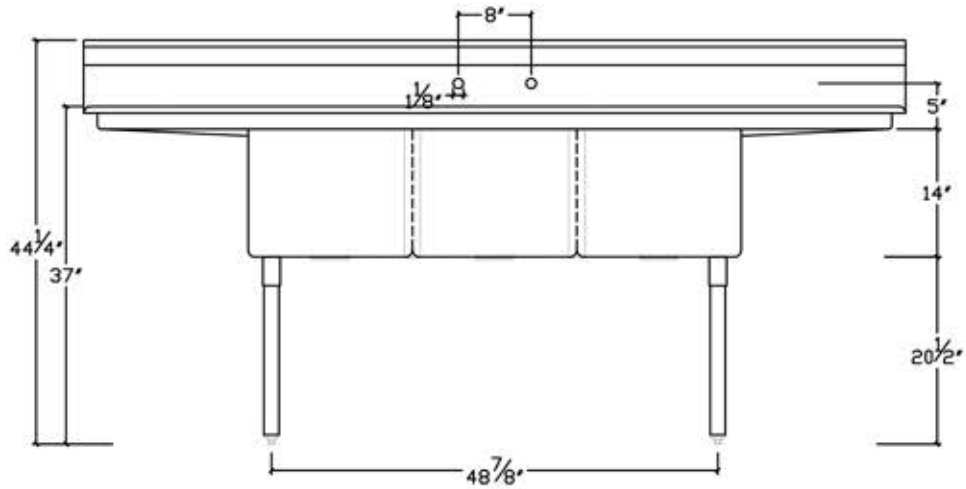
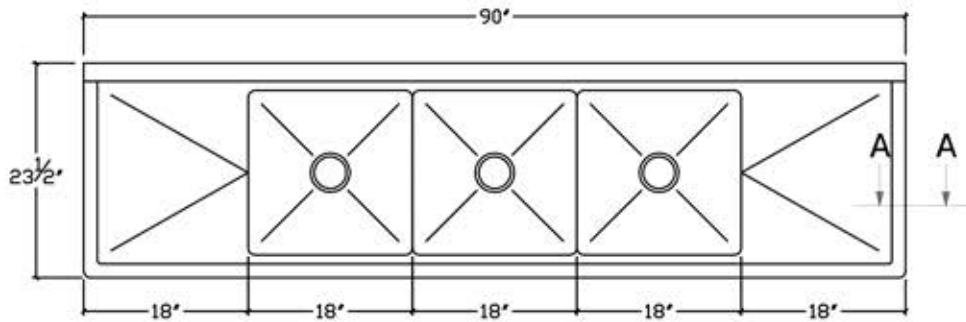

CLOSED HEM
(TO INSIDE OF SINK)

SECTION A-A

GENERAL NOTES

- * TOP - 16 GA. 304 S/S #3 POL.
 - * LEGS - 16 GA. 1-5/8 DIA. S/S TUBING.
 - * FEET - S/S ADJUSTABLE FEET.
 - * ALL SEAMS WELDED & POLISHED
 - * NO BURRS OR SHARP EDGES
 - * MEETS NSF STD. 2
- FEATURES
- * 9 3/4" BACK SPLASH.
 - * 3 1/2" DRAIN BASKET INCLUDED.

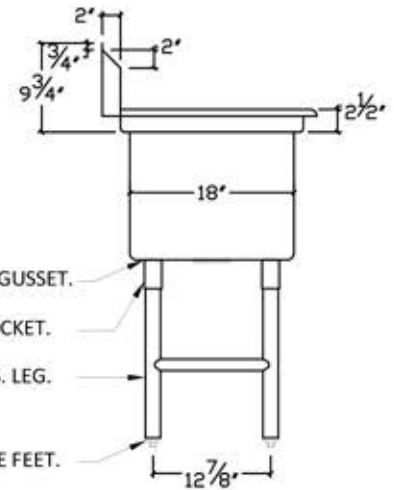

KRATOS

**STAINLESS STEEL
COMPARTMENT SINKS**

29N-002

ITEM NUMBER



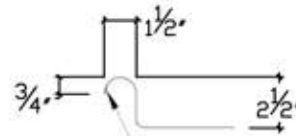
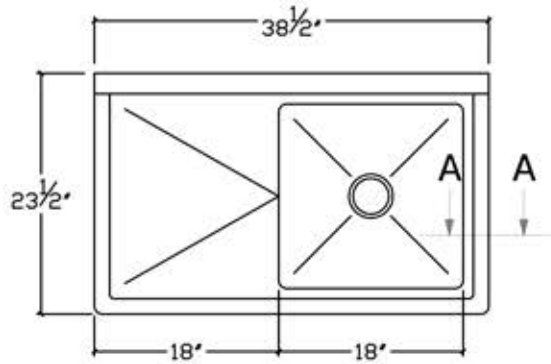

CLOSED HEM
(TO INSIDE OF SINK)

SECTION A-A

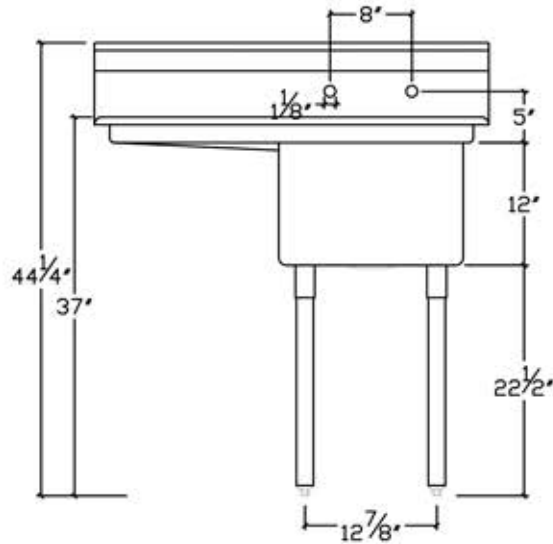

GENERAL NOTES

- * TOP - 16 GA. 304 S/S #3 POL.
 - * LEGS - 16 GA. 1-5/8 DIA. S/S TUBING.
 - * FEET - S/S ADJUSTABLE FEET.
 - * ALL SEAMS WELDED & POLISHED
 - * NO BURRS OR SHARP EDGES
 - * MEETS NSF STD. 2
- FEATURES
- * 9 3/4" BACK SPLASH.
 - * 3 1/2" DRAIN BASKET INCLUDED.

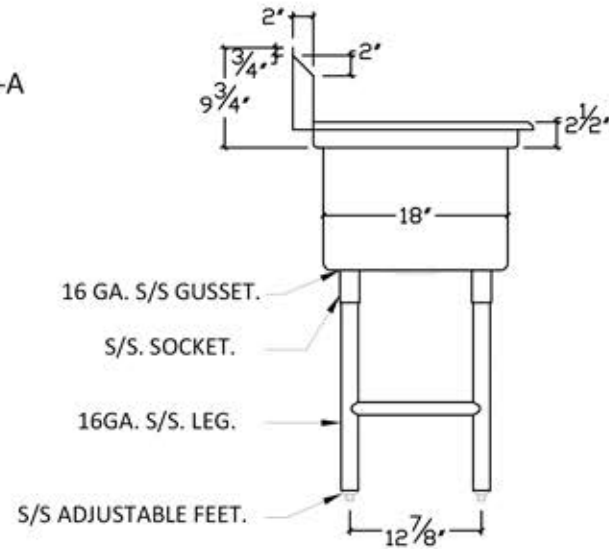

KRATOS

**STAINLESS STEEL
COMPARTMENT SINKS**

29N-008-LT

ITEM NUMBER



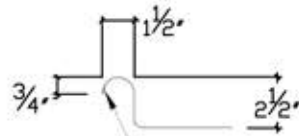
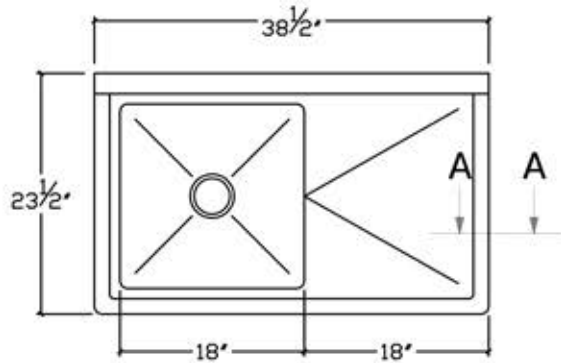

CLOSED HEM
(TO INSIDE OF SINK)

SECTION A-A

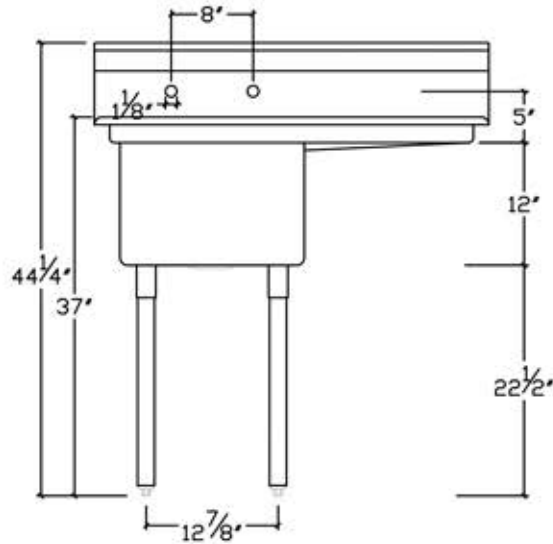

GENERAL NOTES

- * TOP - 16 GA. 304 S/S #3 POL.
 - * LEGS - 16 GA. 1-5/8 DIA. S/S TUBING.
 - * FEET - S/S ADJUSTABLE FEET.
 - * ALL SEAMS WELDED & POLISHED
 - * NO BURRS OR SHARP EDGES
 - * MEETS NSF STD. 2
- FEATURES
- * 9 3/4" BACK SPLASH.
 - * 3 1/2" DRAIN BASKET INCLUDED.

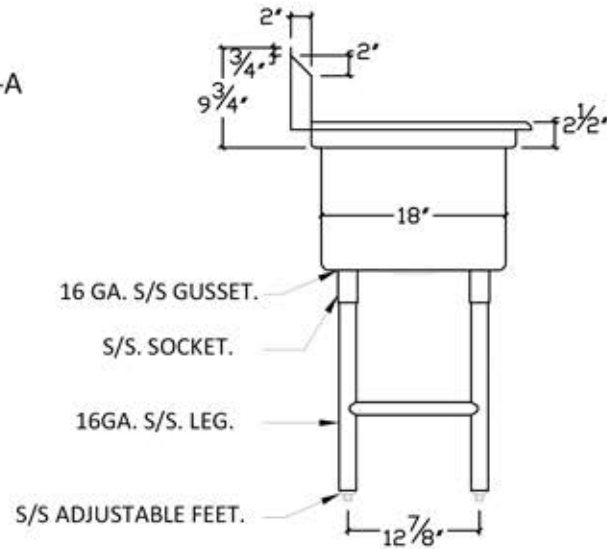

KRATOS

**STAINLESS STEEL
COMPARTMENT SINKS**

29N-008-RT

ITEM NUMBER

