

# KRATOS

PROJECT NAME: \_\_\_\_\_

LOCATION: \_\_\_\_\_

ITEM #: \_\_\_\_\_ QTY: \_\_\_\_\_

MODEL: \_\_\_\_\_

## CHARBROILERS

*Transform your countertop  
into a cooking surface!*



29Y-003



29Y-001



Intertek



Intertek



29Y-002

## FEATURES

- REMOVABLE CAST IRON COOKING GRATES
- SHIPS READY TO USE FOR NATURAL GAS, FIELD CONVERTIBLE TO LIQUID PROPANE
- INDEPENDENT CONTROLS FOR EACH BURNER FOR USER VERSATILITY
- CAST IRON RADIANTS ENSURE A HOT COOKING SURFACE
- 1 YEAR WARRANTY
- ETL, ETL SANITATION CERTIFIED

## SPECIFICATIONS

ITEM	WIDTH	DEPTH	HEIGHT	BURNERS	BTU	GAS TYPE	COOKING AREA
29Y-001	24"	29.5"	15.25"	2	70,000	NAT/LP	20.6 x 24
29Y-002	36"	29.5"	15.25"	3	105,000	NAT/LP	20.6 x 36
29Y-003	48"	29.5"	15.25"	4	140,000	NAT/LP	20.6 x 48



PROJECT NAME: \_\_\_\_\_

LOCATION: \_\_\_\_\_

ITEM #: \_\_\_\_\_ QTY: \_\_\_\_\_

MODEL: \_\_\_\_\_

## CHARBROILERS

**SIDE**

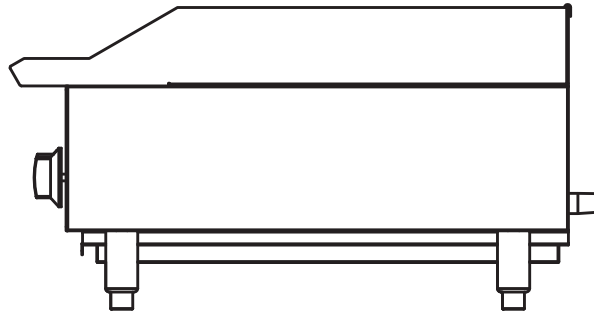

DEPTH 29.5"

**FRONT**

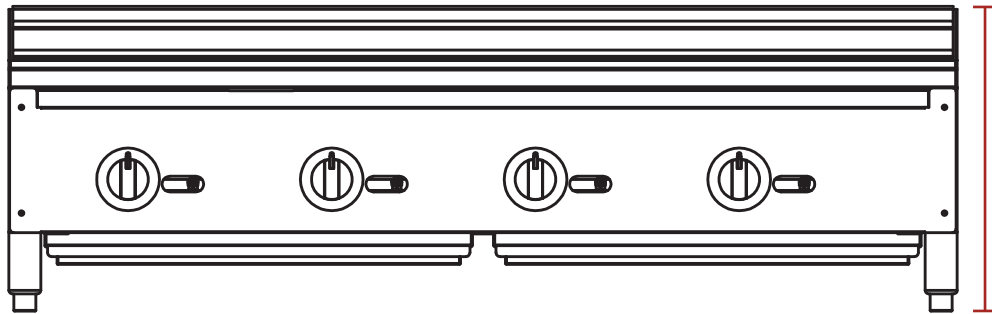

HEIGHT  
15.25"

COOKING AREA  
20.6" x 48"

**TOP**

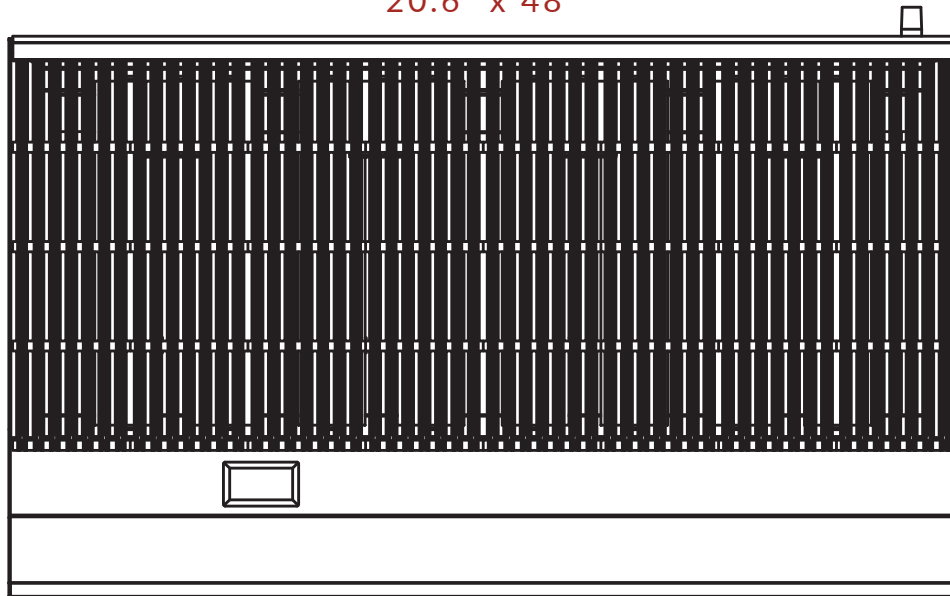

WIDTH 48"



PROJECT NAME: \_\_\_\_\_

LOCATION: \_\_\_\_\_

ITEM #: \_\_\_\_\_ QTY: \_\_\_\_\_

MODEL: \_\_\_\_\_

# CHARBROILERS

**SIDE**

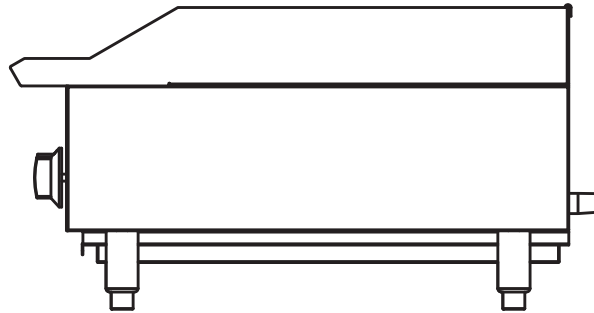

DEPTH 29.5"

**FRONT**

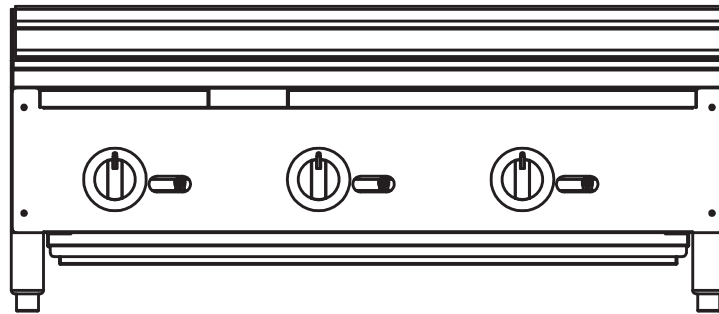

HEIGHT  
15.25"

COOKING AREA  
20.6" x 36"

**TOP**

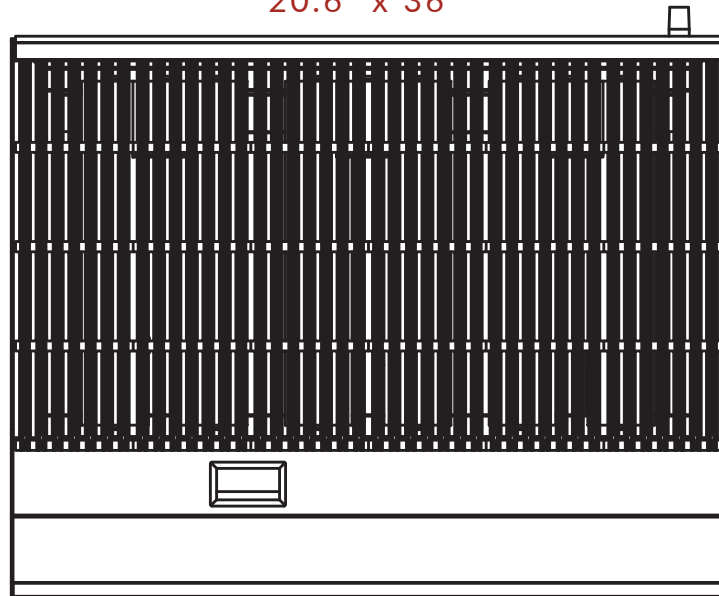

WIDTH 36"

## CHARBROILERS

**SIDE**

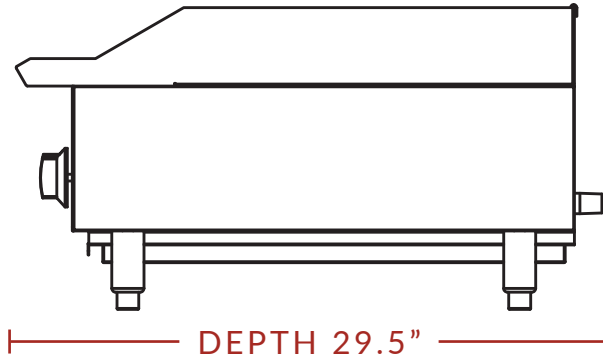

**FRONT**

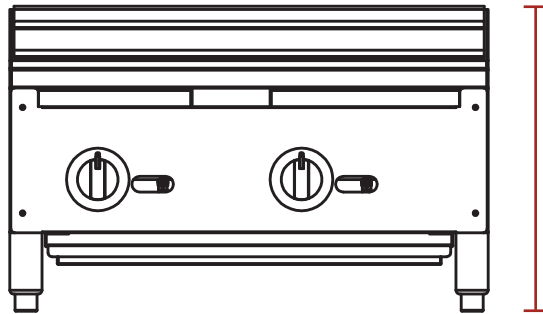

COOKING AREA  
20.6" x 24"

**TOP**

