

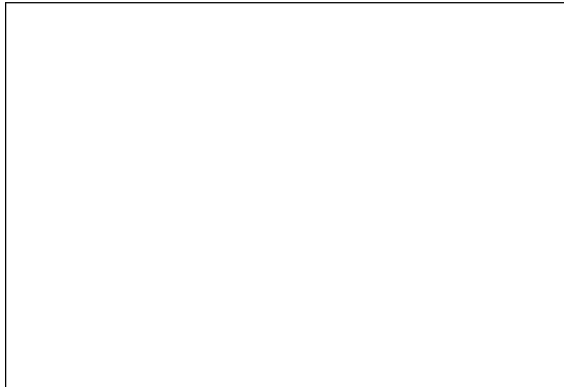

Fred Silver  
& Company

# 360° Dome Mirrors

Available in Acrylic and PETG



- Provides 360° viewing area.
- Ideal for retail applications, larger viewing area acts as a great deterrent to theft.
- Ideal for manufacturing applications, larger viewing area prevents accidents.
- Comes with chain kit so it can be suspended or can be directly mounted to ceiling or wall.

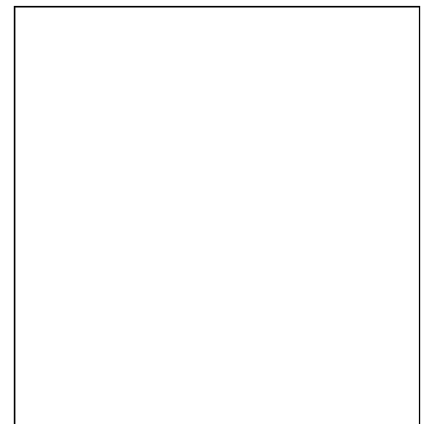
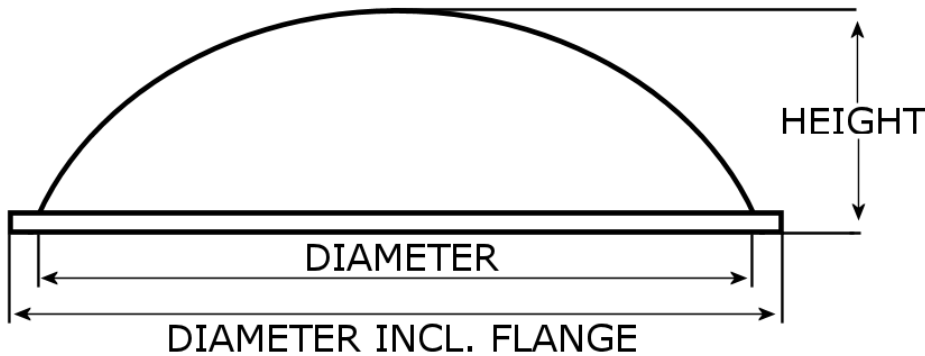

ACRYLIC MODELS				
MODEL #	DIAMETER	DIAMETER INCL. FLANGE	HEIGHT/DEPTH	SHIP WEIGHT
DOME-X-18	18"	19.125"	8.25"	4 lbs.
DOME-X-26	26"	27.125"	10.125"	6 lbs.
DOME-X-32	32"	33.25"	13.875"	9 lbs.
DOME-X-36	36"	37.375"	15.5"	16 lbs.
DOME-X-48	48"	47.75"	18"	34 lbs.

PETG MODELS				
MODEL #	DIAMETER	DIAMETER INCL. FLANGE	HEIGHT/DEPTH	SHIP WEIGHT
PG-DOME-18	18"	19.125"	8.25"	4 lbs.
PG-DOME-26	26"	27.125"	10.125"	6 lbs.
PG-DOME-32	32"	33.25"	13.875"	9 lbs.
PG-DOME-36	36"	37.375"	15.5"	16 lbs.
PG-DOME-48	48"	47.75"	18"	34 lbs.

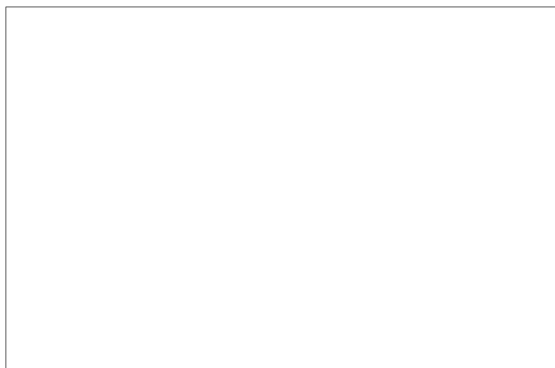

- Provides 180° viewing area.
- Ideal for retail and industrial applications, can be placed at end of aisles to prevent collisions.
- Can be directly mounted to ceiling or wall with standard screws using pre-drilled holes in mirror flange. (Screws not included)

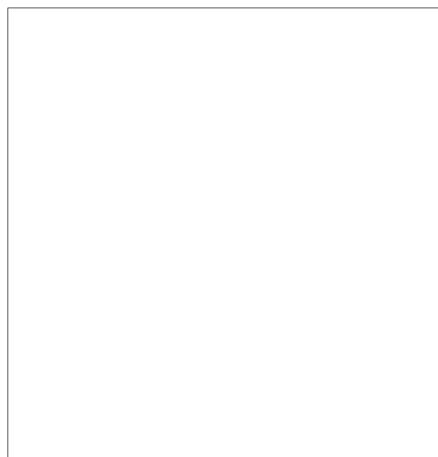
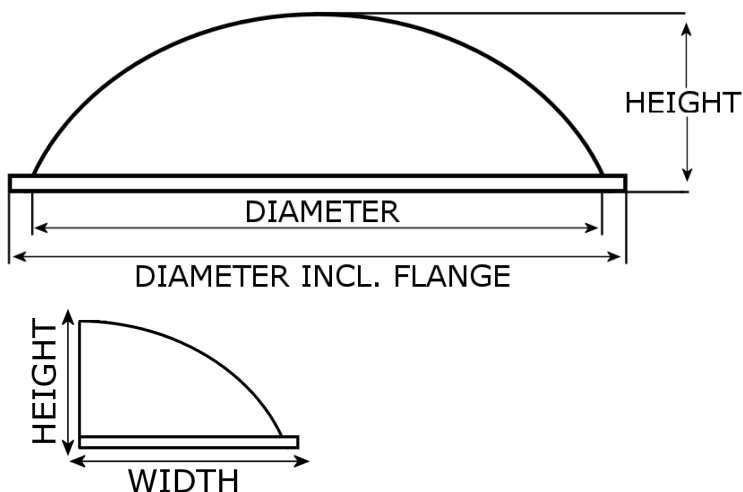

**ACRYLIC MODELS**

MODEL #	DIAMETER	DIAMETER INCL. FLANGE	HEIGHT/DEPTH	SHIP WEIGHT
H-DOME-18	1/2 of 18"	1/2 of 19.125"	8.25"	2 lbs.
H-DOME-26	1/2 of 26"	1/2 of 27.125"	10.125"	3 lbs.
H-DOME-32	1/2 of 32"	1/2 of 33.25"	13.875"	5 lbs.
H-DOME-36	1/2 of 36"	1/2 of 37.375"	15.5"	6 lbs.
H-DOME-48	1/2 of 48"	1/2 of 47.75"	18"	17 lbs.

**PETG MODELS**

MODEL #	DIAMETER	DIAMETER INCL. FLANGE	HEIGHT/DEPTH	SHIP WEIGHT
PG-HD-18	1/2 of 18"	1/2 of 19.125"	8.25"	2 lbs.
PG-HD-26	1/2 of 26"	1/2 of 27.125"	10.125"	3 lbs.
PG-HD-32	1/2 of 32"	1/2 of 33.25"	13.875"	5 lbs.
PG-HD-36	1/2 of 36"	1/2 of 37.375"	15.5"	6 lbs.
PG-HD-48	1/2 of 48"	1/2 of 47.75"	18"	17 lbs.



Fred Silver  
& Company

90° Quarter Dome Mirrors

Available in Acrylic and PETG

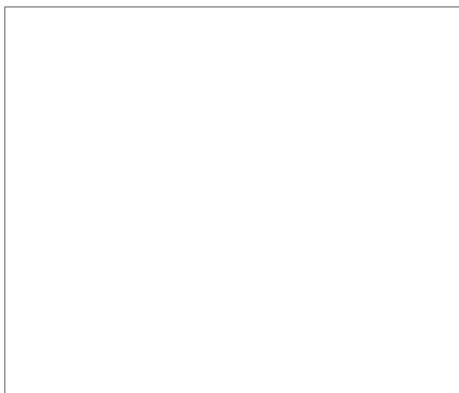

- Provides 90° viewing area.
- Ideal for retail and industrial applications, can be placed in corners to prevent collisions at "L" intersections.
- Can be directly mounted to ceiling with standard screws using pre-drilled holes in mirror flange. (Screws not included)

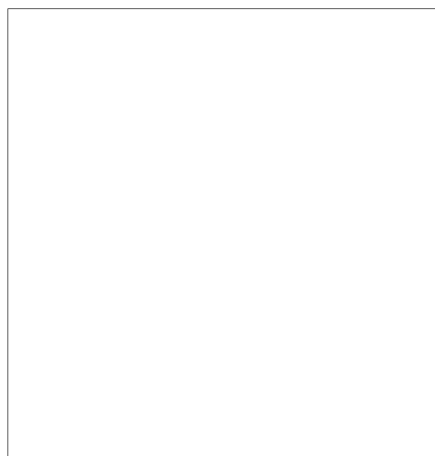
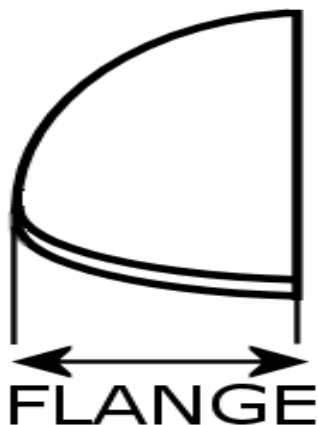

ACRYLIC MODELS				
MODEL #	WIDTH	WIDTH INCL. FLANGE	HEIGHT/DEPTH	SHIP WEIGHT
Q-DOME-18	8.625"	9.875"	9"	1 lbs.
Q-DOME-26	12.325"	13"	10.625"	3 lbs.
Q-DOME-32	15"	16.5"	13.5"	4 lbs.
Q-DOME-36	17.25"	18.25"	16.5"	5 lbs.
Q-DOME-48	22.5"	23.75"	19"	8 lbs.

PETG MODELS				
MODEL #	WIDTH	WIDTH INCL. FLANGE	HEIGHT/DEPTH	SHIP WEIGHT
PG-QD-18	8.625"	9.875"	9"	1 lbs.
PG-QD-26	12.325"	13"	10.625"	3 lbs.
PG-QD-32	15"	16.5"	13.5"	4 lbs.
PG-QD-36	17.25"	18.25"	16.5"	5 lbs.
PG-QD-48	22.5"	23.75"	19"	8 lbs.