



# FLAV-R-SAVOR® PORTABLE HOLDING CABINETS

Models FSHC-6W1, FSHC-6W2 FSHC-7-1, FSHC-7-2

The Hatco Flav-R-Savor Portable Holding Cabinet is capable of holding all types of hot foods at optimum serving temperatures. Thermostatically-controlled *heat* and *humidity* allows you to prepare food in advance of peak periods and hold it for hours.

## FLEXIBILITY

This easy to maneuver Portable Holding Cabinet is made of stainless steel and painted silver-gray top, sides, and back. It features a digital temperature readout and a large tempered glass or insulated stainless steel door. Convenient tray slides hold food pans on 3" (76 mm) centers or 1½" (38 mm) centers, and can be removed easily for cleaning.

The Flav-R-Savor Portable Holding Cabinet is perfect for serving counters, buffet lines, drive-up windows, point-of-service or preparation areas. FSHC-6W1 and -6W2 units are small enough to fit under normal kitchen counters when ordered with low profile casters.

The countertop Flav-R-Savor Holding and Display Cabinet can be mounted on top of the Portable Holding Cabinet to create a hot food merchandising system. This combination provides storage and generates impulse sales of hot foods in shopping malls, sport venues, convention centers, and amusement parks.

Portable Holding Cabinets can be stacked one on top of the other providing two separate humidified temperature zones. Ideal for schools, hospitals, concessions, and cafeterias where backup food storage is needed.

The Glo-Ray® Carving Station is available to be placed on top of the Flav-R-Savor Portable Holding Cabinet to create a complete serving station for buffet lines.

## QUALITY

The following features assure the finest performance for years to come:

- Thermostatically-controlled heat and humidity holds hot food at optimum serving temperatures longer.
- Allows preparation of food in advance of peak serving periods.
- Electrical components, controls, and water reservoir are located at the top for easy access.
- Adjustable humidity and temperature controls, digital temperature readout, insulated side walls, field reversible glass doors, large swivel casters with wheel locks, and 6' (1829 mm) recessed cord and plug are standard.



Model FSHC-7-1 with standard 4" (102 mm) casters and accessory food pans



CHANGE FOR THE BETTER WITH ENERGY STAR



Model FSĐT-1X stacked on Model FSHC-7-1 with accessory food pans



FSHC-7-1/FSHC-7-1 stacked with accessory hardware and food pans



Model FSHC-6W1 with optional *Designer* Color on side and top, and accessory food pans



CHANGE FOR THE BETTER WITH ENERGY STAR



METAL SHEATHED AIR HEATING ELEMENTS  
GUARANTEED AGAINST BURNOUT AND BREAKAGE  
FOR TWO YEARS.

HATCO CORPORATION P.O. Box 340500 Milwaukee, WI 53234-0500 U.S.A.  
(800) 558-0607 • (414) 671-6350 • Fax (800) 543-7521 • Int'l. Fax (414) 671-3976  
www.hatcocorp.com • E-mail: equipsales@hatcocorp.com

Form No. FSHC-1005(S)-1

Printed in U.S.A.



# FLAV-R-SAVOR® PORTABLE HOLDING CABINETS

Models FSHC-6W1, FSHC-6W2 FSHC-7-1, FSHC-7-2

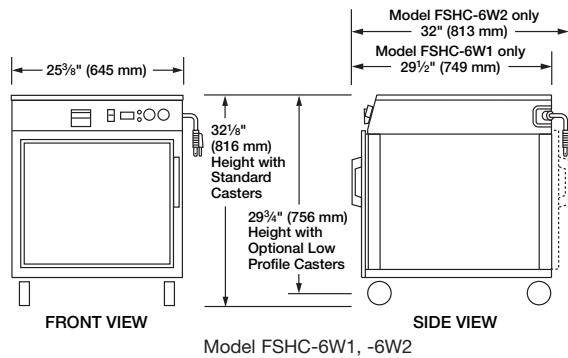

Model FSHC-6W1, -6W2

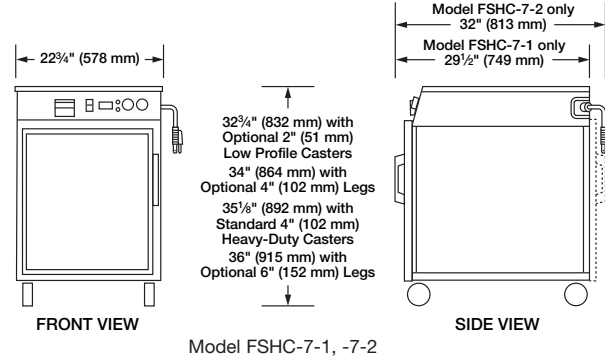

Model FSHC-7-1, -7-2

## SPECIFICATIONS

Model	Type	Rack Style	Shipping Weight
FSHC-6W1	1 Door	Adjustable Angle Slides*	175 lbs. (79 kg)
FSHC-6W2†	2 Door	Adjustable Angle Slides*	179 lbs. (81 kg)
FSHC-7-1	1 Door	Adjustable Angle Slides*	168 lbs. (76 kg)
FSHC-7-2†	2 Door	Adjustable Angle Slides*	172 lbs. (78 kg)

\* 7 slides on each side. Sheet Pans not included.

† Two-door pass-through single cabinet, **not** two units stacked.

• 6 slides on each side. Sheet Pans not included.

## WATER QUALITY REQUIREMENTS

Water supply in excess of 3.0 grains of hardness per gallon (GPG) (.75 grains of hardness per liter) must be treated and softened before being used. Water containing over 3.0 GPG (.75 GPL) will decrease the efficiency and reduce the operating life of the unit.

**Note: Product failure caused by liming or sediment buildup is not covered under warranty.**

## Pan Capacity

Model FSHC-6W1 and -6W2 include stainless steel angle slides which will accommodate six 18" x 26" (457 x 660 mm) sheet pans on 3" (76 mm) centers, eleven 18" x 26" (457 x 660 mm) sheet pans on 1 1/2" (38 mm) centers, or twelve 12" x 20" (305 x 508 mm) food pans (six 2/1 Gastronorm pans) on 3" (76 mm) centers, or eleven 2/1 Gastronorm pans on 1 1/2" (38 mm) centers.

Models FSHC-7-1 and -7-2 include stainless steel angle slides which will accommodate seven 12" x 20" (305 x 508 mm) food pans or 18" x 26" (457 x 660 mm) sheet pans on 3" (76 mm) centers, or fifteen 18" x 26" (457 x 660 mm) sheet pans on 1 1/2" (38 mm) centers with purchase of extra angle slides.

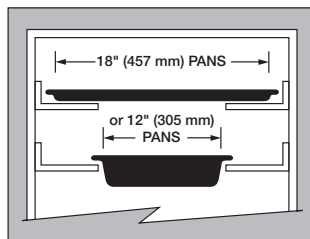

## OPTIONS (NOT FOR RETROFIT)

- Designer Colors (Side Panels and Top): Warm Red, Black, Gray Granite, White Granite, Navy Blue, Hunter Green
- Stainless Steel Side Panels, Back, and Top (FSHC-7-1, -7-2 only, no back panel on two-door models)
- Stainless Steel Door (In lieu of Glass Door) (FSHC-7-1, -7-2 only)
- 2" (51 mm) Low Profile Casters (In lieu of standard Casters)
- 4" (102 mm) Adjustable Legs (In lieu of standard Casters) (FSHC-7-1, -7-2 only)
- 6" (152 mm) Stainless Steel Legs (In lieu of standard Casters) (FSHC-7-1, -7-2 only)

## PRODUCT SPECS

### Portable Holding Cabinet

The humidity-controlled heated Portable Holding Cabinet shall be a Flav-R-Savor® Model ....., rated at ....volts, and ....watts, as manufactured by the Hatco Corporation, Milwaukee, WI 53234 U.S.A.

The cabinet shall have ....door(s), tray slides (or holding rack), insulated side walls, 4" (102 mm) swivel casters with wheel locks

## DIMENSIONS

FSHC-6W1: 25 3/8"W x 29 1/2"D x 32 1/8"H (645 x 749 x 816 mm).

FSHC-6W2: 25 3/8"W x 32"D x 32 1/8"H (645 x 813 x 816 mm).

FSHC-7-1: 22 3/4"W x 29 1/2"D x 35 1/4"H (578 x 749 x 895 mm) on 4" (102 mm) Casters.

FSHC-7-2: 22 3/4"W x 32"D x 35 1/4"H (578 x 813 x 895 mm) on 4" (102 mm) Casters.

Cabinet Opening: FSHC-6W1, -6W2 – 21 1/2"W x 19"H (546 x 483 mm).

FSHC-7-1, -7-2 – 18 1/2"W x 22"H (470 x 559 mm).

Top Surface: FSHC-6W1, -6W2 – 25 3/8"W x 25 7/8"D (645 x 657 mm).

FSHC-7-1, -7-2 – 22 5/8"W x 25 7/8"D (575 x 657 mm).

## VOLTAGE

FSHC-7-1, -7-2: 120 volts, 60 Hz, 1697 watts, 14.1 amps (uses NEMA 5-15P, NEMA 5-20P – Canada).

FSHC-6W1, -6W2: 120 volts, 60 Hz, 1697 watts, 14.1 amps (uses NEMA 5-15P, NEMA 5-20P – Canada).

Export voltages available.

## CORD LOCATION

FSHC-7-1, -7-2: Facing controls, left-hand side panel, bottom right corner.

FSHC-6W1, -6W2: Back of unit, top right side.

## PLUG CONFIGURATIONS

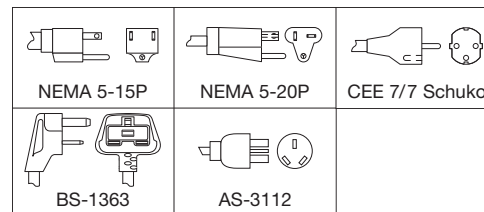

- Audible Low-Water Alarm (FSHC-7-1, -2 only)

## ACCESSORIES

- Stacking Hardware
- Glo-Ray® Carving Station
- Extra Pan Slides
- Sheet Pans – Full and Half-size

or 4" (102 mm) legs, and a 6' (1829 mm) cord and plug. It shall include a water reservoir, humidity selector switch, temperature selector dial, on-off switch, and indicating lights.

Accessories shall include Glo-Ray® Carving Station, sheet pans, and stacking hardware for multiple cabinets.