



MINI DISPLAY WARMER

Models MDW-1X, -2X

The Hatco Mini Display Warmer holds and serves products like sandwiches, cookies, and pretzels at temperatures up to 180°F (82°C). Perfect for convenience stores, restaurants, recreational facilities, and theme parks, and anywhere there is limited counterspace.

FLEXIBILITY

The non-humidified Mini Display Warmer allows food to be showcased on three magnetically adjustable shelves for maximum visibility. One or two-door models are available for server and self-serve operations. The optional hood with backlit sign cutout can be rotated to face any side. Unit available in *Designer* colors with black hood.

QUALITY

The following features assure the finest performance for years to come:

- Three magnetically adjustable shelves for horizontal or slanted displays provide flexibility for a variety of product choices.
- Tempered glass sides and incandescent light to showcase food products.
- Optional hood with backlit sign cutout (sign included) can be rotated to face any side.
- Single door or pass-through models available. Doors are field reversible for right or left opening and can be on any side of the unit.
- Thermostat control with rocker switch for precise temperature control.



Model MDW-1X with optional hood with backlit sign cutout on one side (sign included)



Magnetically adjustable shelves provide flexibility for a variety of product choices

METAL SHEATHED AIR HEATING ELEMENTS
GUARANTEED AGAINST BURNOUT AND BREAKAGE
FOR TWO YEARS.



HATCO CORPORATION P.O. Box 340500 Milwaukee, WI 53234-0500 U.S.A.
(800) 558-0607 • (414) 671-6350 • Fax (800) 543-7521 • Int'l. Fax (414) 671-3976
www.hatcocorp.com • E-mail: equipsales@hatcocorp.com

Form No. MDW Spec Sheet

Printed in U.S.A.
July 2009



MINI DISPLAY WARMER

Models MDW-1X, -2X

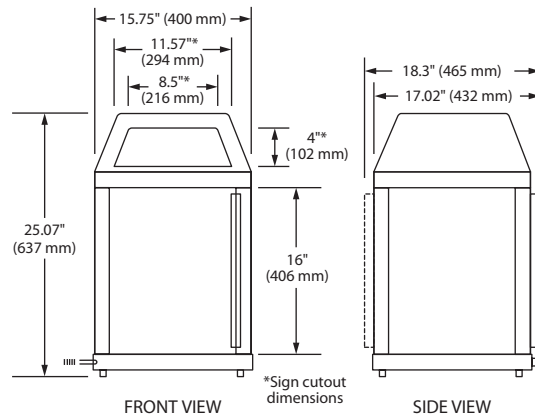

SPECIFICATIONS

Model	Type	Shipping Weight
MDW-1X	1 Door w/3 Shelves	47 lbs. (21 kg)
MDW-2X	2 Doors w/3 Shelves	50 lbs. (23 kg)

DIMENSIONS

MDW-1X: 15.75" W x 17.02" D x 25.07" H (400 x 432 x 637 mm).

MDW-2X: 15.75" W x 18.3" D x 25.07" H (400 x 465 x 637 mm).

Cabinet Opening: 12.4" W x 15.6" H (315 x 396 mm).

VOLTAGE

120 volts, 470 watts, 3.9 amps (uses NEMA 5-15P).

CORD LOCATION

Facing controls, bottom right corner.

PLUG CONFIGURATIONS

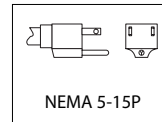

OPTIONS (NOT FOR RETROFIT)

- Designer Colors:* Warm Red, Black (standard), Gray Granite, White Granite, Navy Blue, Hunter Green, Antique Copper
- Hood with Backlit Sign Cutout on One Side (Sign included)

PRODUCT SPECS

Mini Display Warmer

The Mini Display Warmer shall be a Model ... rated at ... volts and ... watts, as manufactured by the Hatco Corporation, Milwaukee, WI 53234 U.S.A.

With 24/7 service (U.S. and Canada only), the Mini Display Warmer

Cabinet shall have ... door(s), tempered glass sides and doors, and incandescent display light. It shall include a temperature selector dial, on-off rocker switch, three adjustable shelves, and a 6' (1829 mm) cord with plug attached.