



FLAV-R-FRESH® IMPULSE DISPLAY CABINETS

Models FDWD-1, FDWD-1X, FDWD-2, FDWD-2X

Hatco has a profitable way to create impulse food sales with the Flav-R-Fresh® Holding and Display Cabinet. Controlled moisturized heat lets you display and hold hot foods longer using minimum counter space.

FLEXIBILITY

The Hatco Flav-R-Fresh® has separate heat and humidity controls to keep crisp foods crisp and moist foods moist, not just for minutes but for hours. It holds everything from hot pretzels to 15" (381 mm) pizzas, croissants to bagels, and even hot dogs and meat pies.

Electrical components, controls, and water reservoir are located at the top for easy access. Electronic controls monitor cabinet temperature.

Models with two doors are available for pass-through convenience and a variety of merchandising racks help enhance food appeal.

The Hatco Flav-R-Fresh is ideal for restaurants, pizzerias, convenience stores, concession stands, snack bars, and kiosks.

QUALITY

The following features assure the finest performance for years to come:

- The new rounded Euro designed cabinet features tempered glass sides and door for full-view display.
- Teflon coated, incandescent light enhances food appeal while safe-guarding food products from bulb breakage.
- Single- or double-door opening models.
- Food decals and merchandising signs are available to help promote product.
- Available in *Designer* colors: Warm Red, Black, Gray Granite, White Granite, Navy Blue, Hunter Green, Antique Copper, non-standard colors are non-returnable
- Doors are reversable (excludes self-closing door)



Model FDWD-1 with accessory 3-tier Pretzel Tree rack and accessory sign from www.hatcographics.com

Equipment
On Signage Program
Hatcographics.com



Model FDWD-2X with stationary 4-shelf multi-purpose rack

GRAPHIC DECALS (Adhesive)



Hot Pizza

Hot Pretzels

Designed to attract attention and stimulate sales, Flav-R-Fresh offers eye-catching food decals (Pizza, Hot Pizza, or Hot Pretzels in bright red with yellow letters)



ONE YEAR ON-SITE PARTS AND LABOR WARRANTY,
PLUS ONE ADDITIONAL YEAR PARTS-ONLY WARRANTY
ON ALL METAL SHEATHED AIR HEATING ELEMENTS.

HATCO CORPORATION P.O. Box 340500 Milwaukee, WI 53234-0500 U.S.A.
(800) 558-0607 • (414) 671-6350 • Fax (800) 543-7521 • Int'l. Fax (414) 671-3976
www.hatcocorp.com • E-mail: equipsales@hatcocorp.com

Form No. FDWD Spec Sheet

Printed in U.S.A.
September 2012



FLAV-R-FRESH® IMPULSE DISPLAY CABINETS

Models FDWD-1, FDWD-1X, FDWD-2, FDWD-2X

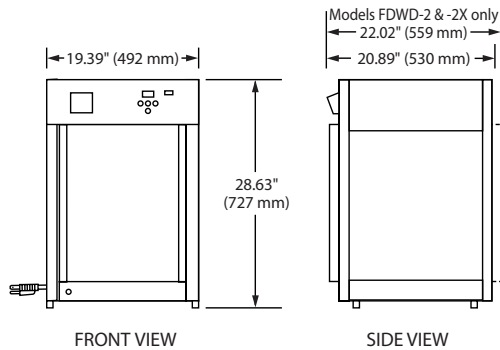

DIMENSIONS

FDWD-1, FDWD-1X: 19.39"W x 20.89"D x 28.63"H*
(492 x 530 x 727 mm).

FDWD-2, FDWD-2X: 19.39"W x 22.02"D x 28.63"H*
(492 x 559 x 727 mm).

* Height includes standard 1" (25 mm) legs.

SPECIFICATIONS

Model* ^o	Type	Rack Style	Shipping Weight
FDWD-1	1 Door	Circle Rack [†] with Rack Motor	90 lbs. (41 kg)
FDWD-1X	1 Door	Multi-Purpose Rack without Rack Motor	90 lbs. (41 kg)
FDWD-2	2 Doors	Circle Rack [†] with Rack Motor	90 lbs. (41 kg)
FDWD-2X	2 Doors	Multi-Purpose Rack without Rack Motor	90 lbs. (41 kg)

* Models FDWD-1 and FDWD-2 include rack motor. Models with "X" designator do not have revolving display and are NOT available for retrofit.

^o Non-humidified units available, unit will only operate in dry mode.

[†] Pretzel Rack available in lieu of Circle Rack.

WATER QUALITY REQUIREMENTS

Water supply in excess of 3.0 grains of hardness per gallon (GPG) (.75 grains of hardness per liter) must be treated and softened before being used. Water containing over 3.0 GPG (.75 GPL) will decrease the efficiency and reduce the operating life of the unit.

Note: Product failure caused by liming or sediment buildup is not covered under warranty.

Cabinet Opening:

FDWD-1, -1X, -2, -2X: 15.75"W x 19.75"H (400 x 502 mm).

VOLTAGE

FDWD-1, -1X, -2, -2X: 120 volts, 60 Hz, 1390 watts, 11.6 amps (uses NEMA 5-15P).

Export voltages available.

CORD LOCATION

FDWD-1, -1X, -2, -2X:

Facing controls, left-hand side panel, lower right corner.

PLUG CONFIGURATIONS

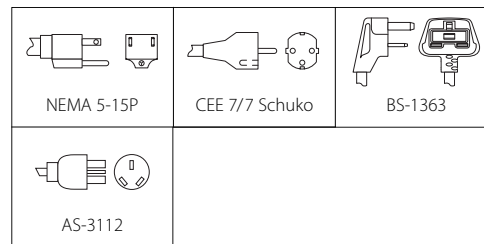

OPTIONS (NOT FOR RETROFIT)

- Designer Colors: Warm Red, Black, Gray Granite, White Granite, Navy Blue, Hunter Green, Antique Copper, non-standard colors are non-returnable
- Self-closing door, in lieu of standard door. Left hinge only, not field reversible
- 6" Sign Holder (for control side only)
- 6³/₈", one-sided sign holder, one per side, 3 max
- 3", 3-sided Sign Holder (FDWD-1, -1X only, signs not included)

ACCESSORIES

- 4" (102 mm) Adjustable Legs
- 4-Tier Circle Rack with Pan Retainers (Requires motorless rack coupling on -X models)
- 4-Shelf Multi-Purpose Rack (Each shelf 13.63"W x 12.62"D (346 x 321 mm))
- 3-Tier Pretzel Tree (Requires rack coupling on -X models)
- Motorless Rack Coupling (For -X models only)
- Graphic Adhesive Decals (3 per set)
Pizza Photo Hot Pizza Hot Pretzel

Display Rack Selection

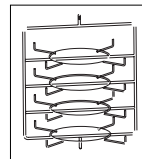

**4-Tier Circle Rack
FDW4TCR**
Rack Opening:
3.25" (83 mm)
Maximum
15" (381 mm)
diameter pans

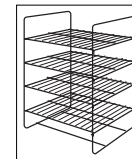

**4-Shelf Multi-Purpose
Rack*
FDW4SMP**
Rack Opening:
3.5" (89 mm)

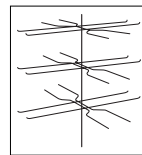

**3-Tier Pretzel Tree
FDW3TPT**
Rack Opening:
5.88" (149 mm)

* Accommodates half-size sheet pans (Not included).

PRODUCT SPECS

Impulse Display Cabinet

The humidity controlled Impulse Display Cabinet shall be a Flav-R-Fresh® Model ... rated at ... volts and ... watts, as manufactured by the Hatco Corporation, Milwaukee, WI 53234 U.S.A.

The cabinet shall have ...door(s), tempered glass sides, stationary rack (or revolving display), and fluorescent display light. It shall include a water reservoir, electronic controls, on-off switch, and indicating lights.

A 6' (1829 mm) cord with plug shall be attached.

Accessories shall include merchandising racks, display sign holders (signs not included), and food graphic decals.

One year on-site parts and labor warranty, plus one additional year parts-only warranty on all metal sheathed air heating elements with 24/7 parts and service assistance (U.S. and Canada only)

HATCO CORPORATION P.O. Box 340500 Milwaukee, WI 53234-0500 U.S.A. • (800) 558-0607 • (414) 671-6350
Fax (800) 543-7521 • Int'l. Fax (414) 671-3976 • www.hatcocorp.com • E-Mail: equipsales@hatcocorp.com