



IMPORTANT NOTE:

Locate the Specification Label on unit to determine exact Model Name and electrical specifications. This information is needed to identify the correct replacement parts. See exploded view illustration(s) for Specification Label location.



Use of replacement parts other than those supplied by Hatco Corporation may result in damage to unit or injury to personnel and will void all warranties.

Intelligent Toast-Qwik® Conveyor Toaster

ITQ Series

<u>Model Name</u>	<u>Page</u>
ITQ-875-1C.....	2
ITQ-1000-1C.....	4
ITQ-1750-2C.....	6

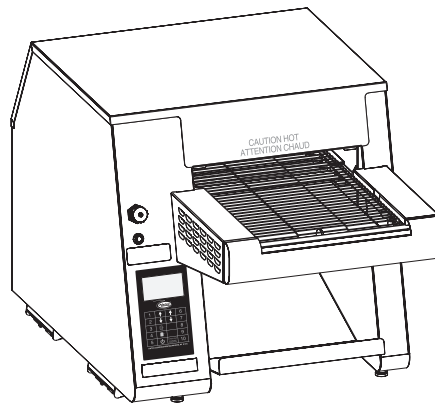
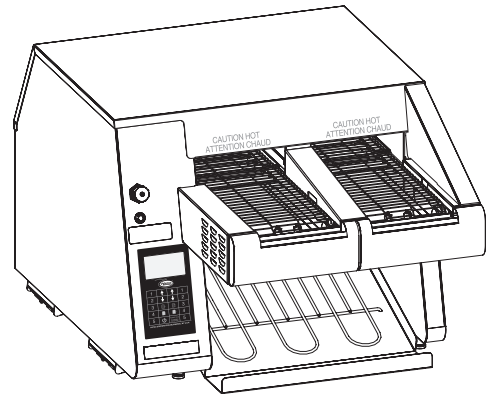
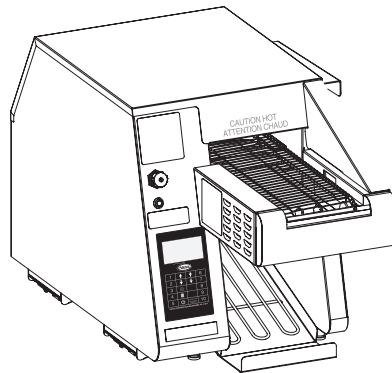

Replacement Parts List

Model ITQ-875-1C

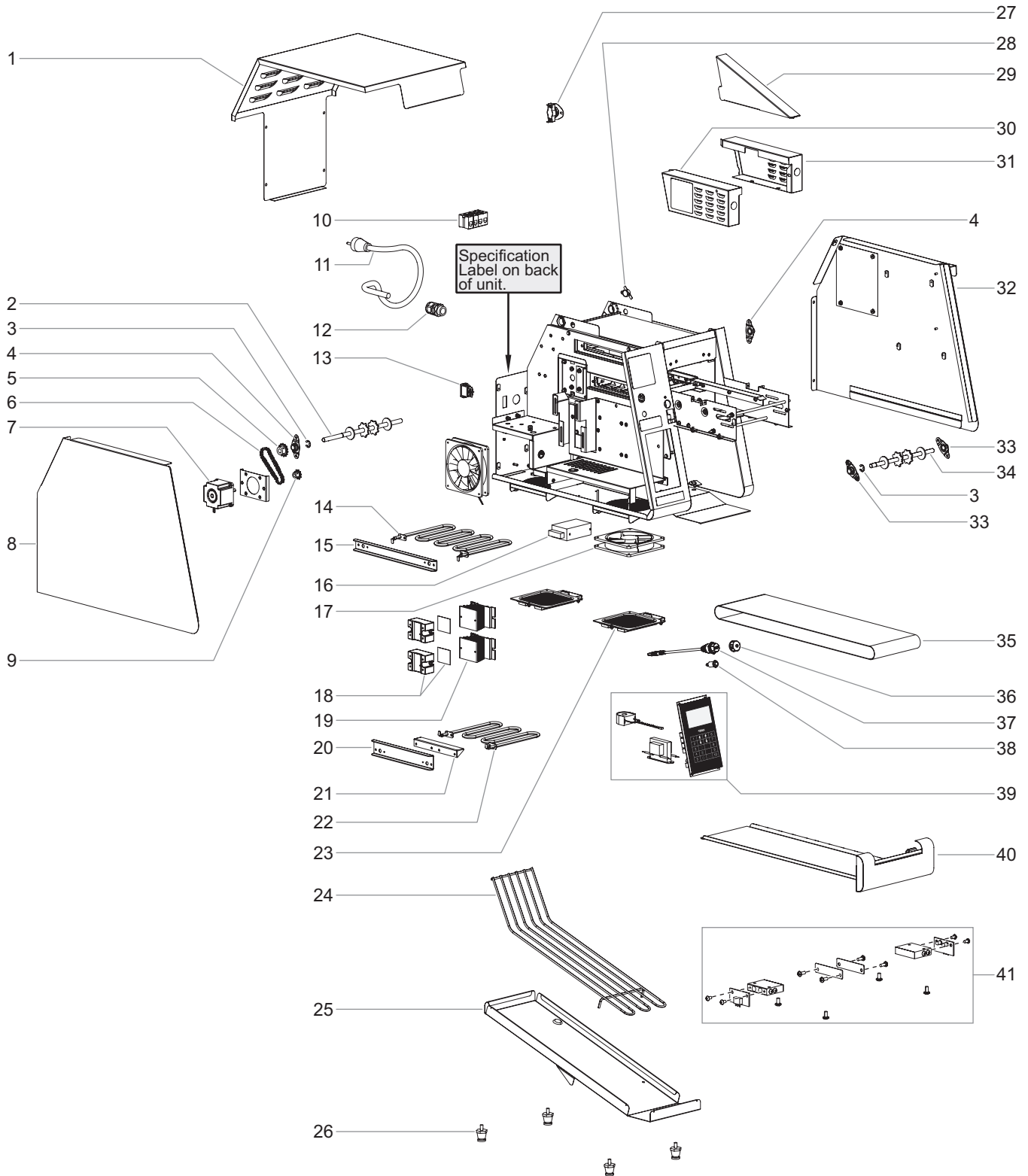

Parts For Model ITQ-875-1C

Item	Description	Part Number	Qty.
1	Top Cover	04.56.282.00	1
2	Drive Shaft Assembly	04.56.293.00	1
3	E-Ring	05.11.035.00	2
4	Bearing Assembly, Rear	04.05.286.00	2
5	Driven Sprocket	05.09.062.00	1
6	Drive Chain	05.03.075.00	1
7	Stepper Motor, Conveyor	02.12.121.00	1
8	Side Cover, Left	04.05.988.00	1
9	Drive Sprocket	05.09.061.00	1
10	Terminal Block	R02.15.047.00	1
11	Power Cord w/Plug		
	NEMA 6-20P (standard)	02.18.111.00	1
	NEMA L6-20P (optional)	02.18.186.00	1
12	Cord Grip	R02.20.259.00	1
13	Power Switch, Rocker	02.19.161.00	1
14	Heating Element, Upper, 1650 W		
	208 V	02.05.960.00	1
	240 V	02.05.987.00	1
15	Bracket, Top Element	04.05.975.00	1
16	Power Supply	02.17.064.00	1
17	Fan, Cooling	02.12.163.00	2
18	Solid State Relay Kit (includes thermal pad)	R02.01.355.00	2
19	Heat Sink, Relay	04.09.872.00	2
20	Bracket, Bottom Element	04.05.897.00	1
21	Belt Support, Element Bracket	04.05.874.00	1
22	Heating Element, Lower, 1050 W		
	208 V	02.05.961.00	1
	240 V	02.05.988.00	1

Item	Description	Part Number	Qty.
23	Filter, Wire Mesh	R02.12.138.00	2
24	Toast Chute Slide	04.56.284.00	1
25	Toast Chute	04.56.283.00	1
26	Leg, 1"	R05.30.081.00	4
27	High Limit Thermostat	R02.16.118.00	1
28	High Limit Thermostat, Mechanical	02.16.192.00	1
29	Heat Shield	04.56.199.00	1
30	Side Cover, Conveyor, Left	04.56.122.00	1
31	Side Cover, Conveyor, Right	04.56.123.00	1
32	Side Cover, Right	04.56.560.00	1
33	Bearing Assembly, Front	04.05.387.00	2
34	Shaft Assembly, Front	04.56.302.00	1
35	Conveyor Belt	05.03.073.00	1
36	Waterproof Cap, USB	02.18.513.00	1
37	USB Cable	02.18.478.00	1
38	Indicator Light, Red	02.19.151.00	1
39	Electronic Touchpad Control Kit *	R02.01.385A.00	1
40	Crumb Tray	R04.56.285.00	1
41	Product Sensor Kit	R02.01.368.00	1
	Wiring Diagram	10-01-1259	

* Electronic Touchpad Control Kit contains electronic control, current sensor, 24 V transformer, and a USB flash drive. Failure of any one of these components requires replacement of all three.

NOTE: All electrical components on Model ITQ-875-1C are designed to operate on supply voltages between 208 V and 240 V.

NOTE: The last four digits in a ten digit numerical serial number are the manufacturing date code.

Example: Serial number 9625061331 has a date code of "1331" which indicates the following: 1331



Model ITQ-1000-1C

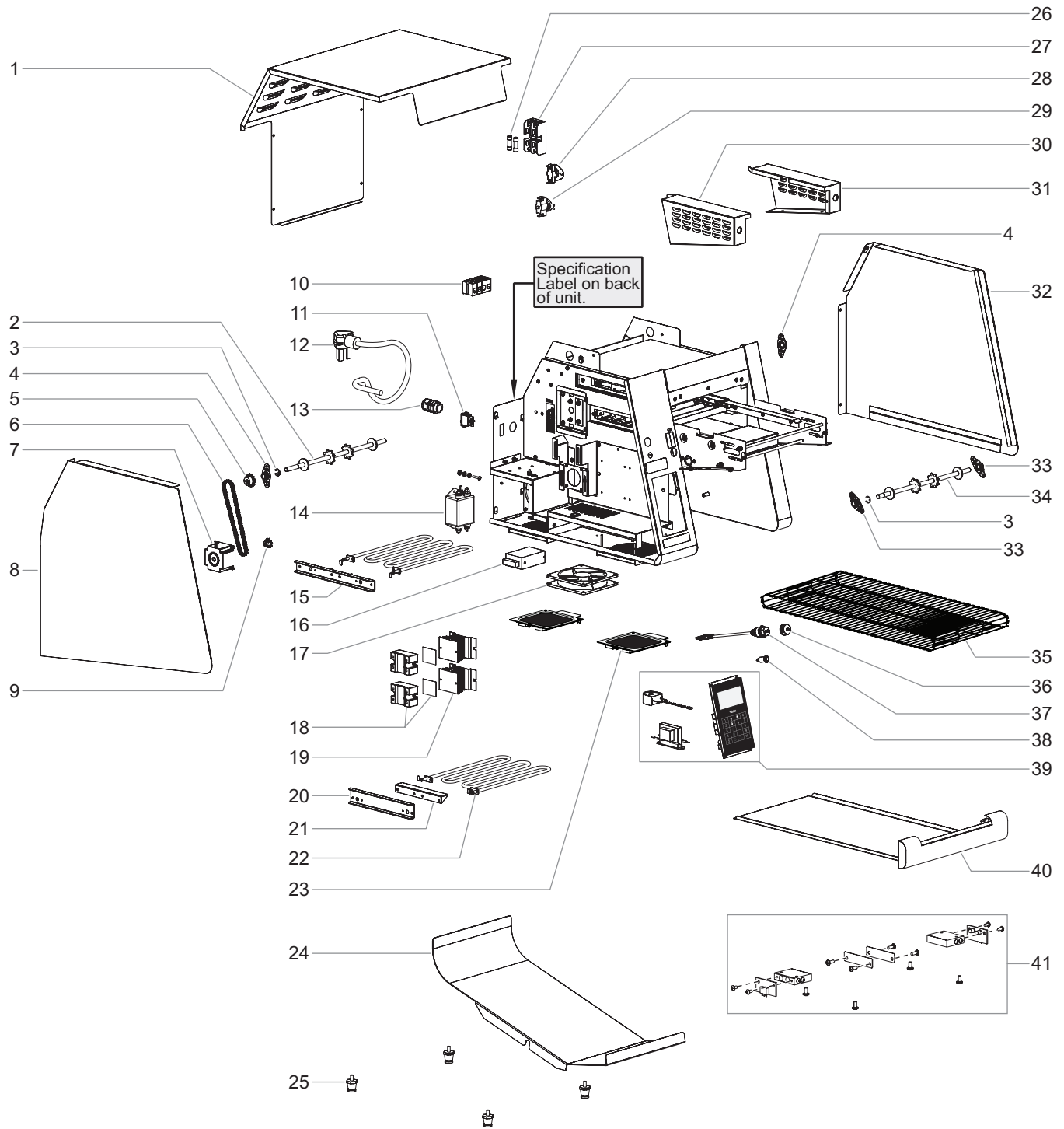

Parts For Model ITQ-1000-1C

Item	Description	Part Number	Qty.
1	Top Cover	04.05.920.00	1
2	Drive Shaft Assembly	04.05.932.00	1
3	E-Ring	05.11.035.00	2
4	Bearing Assembly, Rear	04.05.286.00	2
5	Driven Sprocket	05.09.062.00	1
6	Drive Chain	05.03.070.00	1
7	Stepper Motor, Conveyor	02.12.121.00	1
8	Side Cover, Left	04.05.958.00	1
9	Drive Sprocket	05.09.061.00	1
10	Terminal Block	R02.15.047.00	1
11	Power Switch, Rocker	02.19.161.00	1
12	Power Cord w/Plug		
	NEMA 6-30P (standard)	02.18.122.00	1
	NEMA L6-30P (optional)	02.18.150.00	1
	CEE 7/7 Schuko	02.18.038.00	1
	No Plug	02.18.103.00	1
13	Cord Grip	R02.20.259.00	1
14	EMI Filter (CE only)	02.13.359.00	1
15	Bracket, Top Element	04.05.940.00	1
16	Power Supply	02.17.064.00	1
17	Fan, Cooling	02.12.125.00	2
18	Solid State Relay Kit (includes thermal pad)	R02.01.355.00	2
19	Heat Sink, Relay	04.09.872.00	2
20	Bracket, Bottom Element	04.05.897.00	1
21	Belt Support, Element Bracket	04.05.874.00	1
22	Heating Element		
	208–240 V, 2150 W	02.05.886.00	2
	230 V, 1800 W	02.05.953.00	2

Item	Description	Part Number	Qty.
23	Filter, Wire Mesh	R02.12.138.00	2
24	Toast Chute	04.05.921.00	1
25	Leg, 1"	R05.30.081.00	4
26	Fuse, 250 V, 15 A (includes 2)	R02.03.052.02	1
27	Fuse Block	02.03.022.00	1
28	High Limit Thermostat	R02.16.118.00	1
29	High Limit T-Stat, Manual (CE only)	02.16.195.00	1
30	Side Cover, Conveyor, Left	04.05.828.00	1
31	Side Cover, Conveyor, Right	04.05.829.00	1
32	Side Cover, Right	04.05.959.00	1
33	Bearing Assembly, Front	04.05.387.00	2
34	Shaft Assembly, Front	04.05.933.00	1
35	Conveyor Belt	05.03.069.00	1
36	Waterproof Cap, USB	02.18.513.00	1
37	USB Cable	02.18.478.00	1
38	Indicator Light, Red	02.19.151.00	1
39	Electronic Touchpad Control Kit *	R02.01.385A.00	1
40	Crumb Tray	R04.56.006.00	1
41	Product Sensor Kit	R02.01.368.00	1
42	Filter Retrofit Kit (not shown) †	R04.56.145.00	1
	Wiring Diagram	10-01-1069	

* Electronic Touchpad Control Kit contains electronic control, current sensor, 24 V transformer, and a USB flash drive. Failure of any one of these components requires replacement of all three.

† Filter Retrofit Kit can be ordered for units with date code 1343 and older to replace old-style foam filters with current wire mesh filters.

NOTE: All electrical components on Model ITQ-1000-1C are designed to operate on supply voltages between 208 V and 240 V.

The shaded areas contain electrical information for **International models only**.

NOTE: The last four digits in a ten digit numerical serial number are the manufacturing date code.

Example: Serial number 9625061331 has a date code of "1331" which indicates the following:

1331
 └── Week Thirty-One
 └── Year 2013

Model ITQ-1750-2C

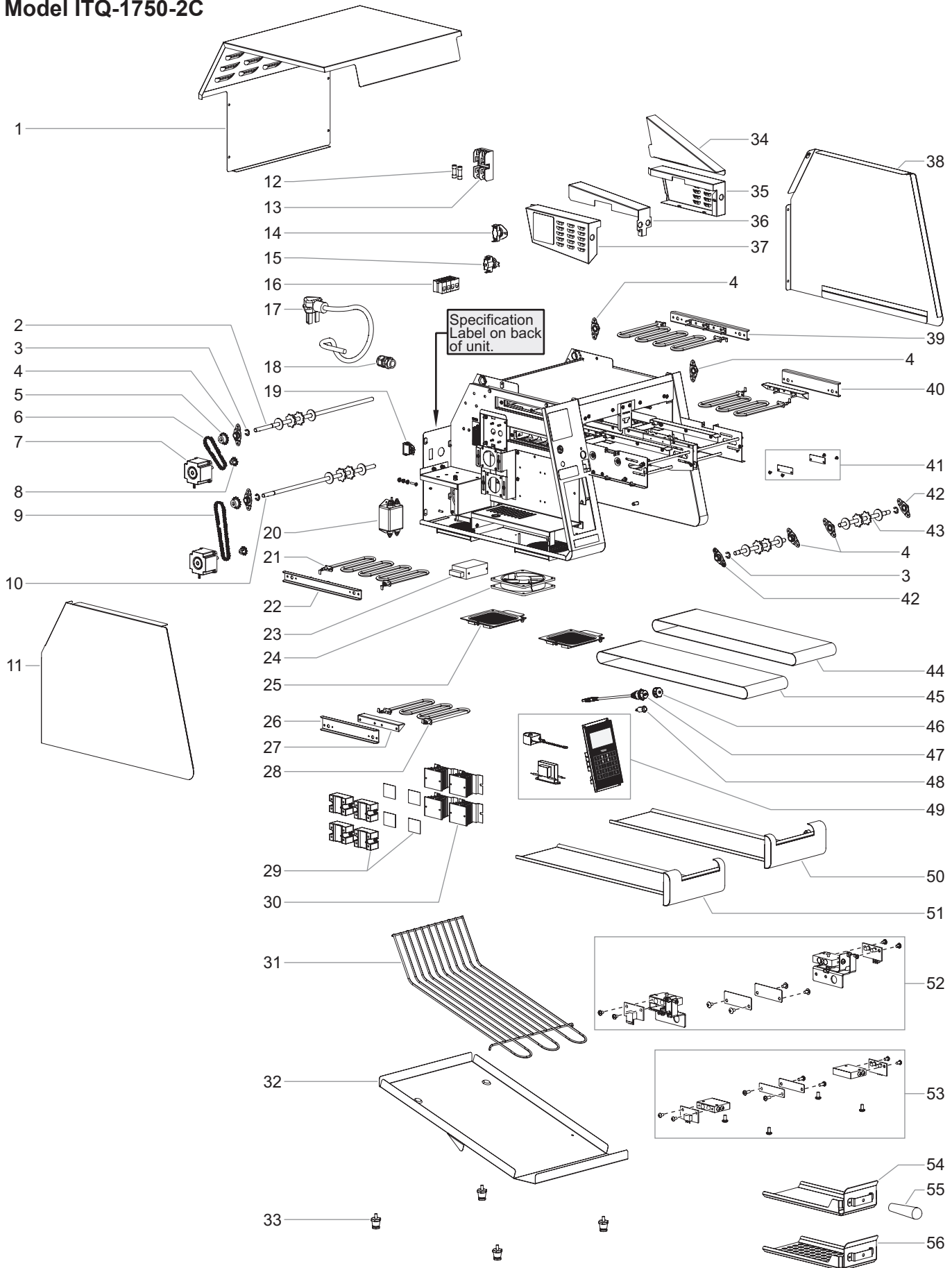

Parts For Model ITQ-1750-2C

Item	Description	Part Number	Qty.
1	Top Cover	04.56.098.00	1
2	Drive Shaft Assembly, Left	04.56.116.00	1
3	E-Ring	05.11.035.00	4
4	Bearing Assembly	04.05.286.00	6
5	Driven Sprocket	05.09.062.00	2
6	Drive Chain, 8.5"	05.03.075.00	1
7	Stepper Motor, Conveyor	02.12.121.00	2
8	Drive Sprocket	05.09.061.00	2
9	Drive Chain, 13"	05.03.074.00	1
10	Drive Shaft Assembly, Right	04.56.117.00	1
11	Side Cover, Left	04.05.988.00	1
12	Fuse, 250 V, 15 A (includes 2)	R02.03.052.02	2
13	Fuse Block	02.03.022.00	1
14	High Limit T-Stat		1
15	High Limit T-Stat, Manual (CE only)	02.16.195.00	1
16	Terminal Block	R02.15.047.00	1
17	Power Cord w/Plug		
	NEMA 6-30P (standard)	02.18.122.00	1
	NEMA L6-30P (optional)	02.18.150.00	1
	No Plug	02.18.103.00	1
18	Cord Grip	R02.20.259.00	1
19	Power Switch, Rocker	02.19.161.00	1
20	EMI Filter (CE only)	02.13.359.00	1
21	Heating Element, Upper, 1500 W		
	208 V	02.05.996.00	2
	240 V	02.05.997.00	2
	230 V	02.05.955.00	2
22	Bracket, Top Element	04.56.975.00	1
23	Power Supply	02.17.064.00	1
24	Fan, Cooling	02.12.125.00	2
25	Filter, Wire Mesh	R02.12.138.00	2
26	Bracket, Bottom Element	04.05.897.00	1
27	Belt Support, Element Bracket	04.05.874.00	2
28	Heating Element, Lower, 980 W		
	208 V	02.05.998.00	2
	240 V	02.05.999.00	2
	230 V	02.05.956.00	2

Item	Description	Part Number	Qty.
29	Solid State Relay Kit (includes thermal pad)	R02.01.355.00	4
30	Heat Sink, Relay	04.09.872.00	4
31	Toast Chute Slide	04.56.228.00	1
32	Toast Chute	04.56.229.00	1
33	Leg, 1"	R05.30.081.00	4
34	Heat Shield	04.56.199.00	1
35	Side Cover, Conveyor, Right	04.56.123.00	1
36	Center Cover, Conveyor	04.56.106.00	1
37	Side Cover, Conveyor, Left	04.56.122.00	1
38	Side Cover, Right	04.56.127.00	1
39	Bracket, Top Element, w/Standoff	04.56.553.00	1
40	Bracket, Bottom Element, w/ Standoff	04.56.552.00	1
41	Reflector Assembly ▲ ‡	R04.56.721.00	2
42	Bearing Assembly w/Nut, Front	04.05.387.00	2
43	Shaft Assembly, Front	04.56.115.00	2
44	Conveyor Belt, Right, 45-1-1/2"	05.03.072.00	1
45	Conveyor Belt, Left, 48"	05.03.073.00	1
46	Waterproof Cap, USB	02.18.513.00	1
47	USB Cable	02.18.478.00	1
48	Indicator Light, Red	02.19.151.00	1
49	Electronic Touchpad Control Kit *	R02.01.385B.00	1
50	Crumb Tray, Right	R04.56.100.00	1
51	Crumb Tray, Left	R04.56.099.00	1
52	Product Sensor/Reflector Kit— Date Code 1716 and newer	R00.02.0112.00	1
53	Product Sensor/Reflector Kit— Date Code 1715 and older	R02.01.368.00	1
54	Food Paddle, Standard	R04.56.182.00	1
55	Handle, Food Paddle	05.30.182.00	1
56	Food Paddle, Perforated	R04.56.183.00	1
57	Filter Retrofit Kit (not shown) †	R04.56.145.00	1
	Wiring Diagram	10-01-1102	

▲ For units with date code **1715** and older, use Reflector Assembly P/N R04.56.218.00.

‡ Included with Product Sensor/Reflector Kit.

* Electronic Touchpad Control Kit contains electronic control, current sensor, 24 V transformer, and a USB flash drive. Failure of any one of these components requires replacement of all three.

† Filter Retrofit Kit can be ordered for units with date code 1343 and older to replace old-style foam filters with current wire mesh filters.

The shaded areas contain electrical information for **International models only**.

NOTE: The last four digits in a ten digit numerical serial number are the manufacturing date code.

Example: Serial number 9625061331 has a date code of "1331" which indicates the following: 1331

└─ Week Thirty-One
└─ Year 2013

AUTHORIZED PARTS DISTRIBUTORS • DISTRIBUTEURS DE PIÈCES AUTORISÉS

ALABAMA

Jones McLeod Appl. Svc.
Birmingham 205-251-0159

ARIZONA

Service Solutions Group
Phoenix 602-234-2443

Byassee Equipment Co.
Phoenix 602-252-0402

CALIFORNIA

Industrial Electric
Commercial Parts & Service, Inc.
Huntington Beach 714-379-7100

Chapman Appl. Service
San Diego 619-298-7106

P & D Appliance
Commercial Parts & Service, Inc.
S. San Francisco 650-635-1900

COLORADO

Hawkins Commercial Appliance
Englewood 303-781-5548

FLORIDA

Whaley Foodservice Repair
Jacksonville 904-725-7800

Whaley Foodservice Repair
Orlando 407-757-0851

B.G.S.I.
Pompano Beach 954-971-0456

Comm. Appliance Service
Tampa 813-663-0313

GEORGIA

TWC Services
Mableton 770-438-9797

Heritage Service Group
Norcross 866-388-9837

Southeastern Rest. Svc.
Norcross 770-446-6177

HAWAII

Burney's Comm. Service, Inc.
Honolulu 808-848-1466

Food Equip Parts & Service
Honolulu 808-847-4871

ILLINOIS

Parts Town
Lombard 708-865-7278

Eichenauer Elec. Service
Decatur 217-429-4229

Midwest Elec. Appl. Service
Elmhurst 630-279-8000

Cone's Repair Service
Moline 309-797-5323

INDIANA

GCS Service
Indianapolis 800-727-8710

IOWA

Goodwin Tucker Group
Des Moines 515-262-9308

KENTUCKY

Service Solutions Group
Lexington 859-254-8854

Service Solutions Group
Louisville 502-451-5411

LOUISIANA

Chandlers Parts & Service
Baton Rouge 225-272-6620

MARYLAND

Electric Motor Service
Baltimore 410-467-8080

GCS Service
Silver Spring 301-585-7550

MASSACHUSETTS

Ace Service Co., Inc.
Needham 781-449-4220

MICHIGAN

Bildons Appliance Service
Detroit 248-478-3320

Commercial Kitchen Service
Bay City 989-893-4561

Midwest Food Equip. Service
Grandville 616-261-2000

MINNESOTA

GCS Service
Minnetonka 800-822-2303
x20365

MISSOURI

General Parts
Kansas City 816-421-5400

Commercial Kitchen Services
St. Louis 314-890-0700

Kaemmerlen Parts & Service
St. Louis 314-535-2222

NEBRASKA

Anderson Electric
Omaha 402-341-1414

NEVADA

Burney's Commercial
Las Vegas 702-736-0006

Hi. Tech Commercial Service
N. Las Vegas 702-649-4616

NEW JERSEY

Jay Hill Repair
Fairfield 973-575-9145

Service Plus
Flanders 973-691-6300

NEW YORK

Acme American Repairs, Inc.
Jamaica 718-456-6544

Alpro Service Co.
Maspeth 718-386-2515

Appliance Installation
Buffalo 716-884-7425

Duffy's Equipment Services, Inc.
Buffalo 800-836-1014

3Wire Northern
Plattsburgh 800-634-5005

Duffy's Equipment Services, Inc.
Sauquoit 800-836-1014

J.B. Brady, Inc.
Syracuse 315-422-9271

NORTH CAROLINA

Authorized Appliance
Charlotte 704-377-4501

OHIO

Akron/Canton Comm. Svc. Inc.
Akron 330-753-6634

Service Solutions Group
Cincinnati 513-772-6600

Commercial Parts and Service
Columbus 614-221-0057

Electrical Appl. Repair Service
Brooklyn Heights 216-459-8700

E. A. Wichman Co.
Toledo 419-385-9121

OKLAHOMA

Hagar Rest. Service, Inc.
Oklahoma City 405-235-2184

Krueger, Inc.
Oklahoma City 405-528-8883

OREGON

Ron's Service, Inc.
Portland 503-624-0890

PENNSYLVANIA

Elmer Schultz Services
Philadelphia 215-627-5401

FAST Comm. Appl. Service
Philadelphia 215-288-4800

Appliance Installation & Service
Pittsburgh 412-809-0244

K & D Service Co.
Harrisburg 717-236-9039

Electric Repair Co.
Reading 610-376-5444

RHODE ISLAND

Marshall Electric Co.
Providence 401-331-1163

SOUTH CAROLINA

Whaley Foodservice Repair
Lexington 803-996-9900

TENNESSEE

Camp Electric
Memphis 901-527-7543

TEXAS

GCS Service
Fort Worth 800-433-1804

Armstrong Repair Service
Houston 713-666-7100

Cooking Equipment Specialist
Mesquite 972-686-6666

Commercial Kitchen Repair Co.
San Antonio 210-735-2811

UTAH

La Monica's Rest. Equip. Service
Murray 801-263-3221

VIRGINIA

Daubers
Norfolk 757-855-4097

Daubers
Springfield 703-866-3600

WASHINGTON

3Wire Restaurant Appliance
Seattle 800-207-3146

WISCONSIN

A.S.C., Inc.
Madison 608-246-3160

A.S.C., Inc.
Milwaukee 414-543-6460

CANADA

ALBERTA

Key Food Equipment Service
Edmonton 780-438-1690

BRITISH COLUMBIA

Key Food Equipment Service
Vancouver 604-433-4484

Key Food Equipment Service
Victoria 250-920-4888

MANITOBA

Air Rite, Inc.
Winnipeg 204-895-2300

NEW BRUNSWICK

EMR Services, Ltd.
Moncton 506-855-4228

ONTARIO

R.G. Henderson Ltd.
Toronto 416-422-5580

Choquette - CKS, Inc.
Ottawa 613-739-8458

QUÉBEC

Choquette - CKS, Inc.
Montreal 514-722-2000

Choquette - CKS, Inc.
Québec City 418-681-3944

UNITED KINGDOM

Marren Group
Northants +44(0)1933 665313

HATCO CORPORATION

P.O. Box 340500

Milwaukee, WI 53234-0500 U.S.A.

800-558-0607 414-671-6350

partsandservice@hatcocorp.com

www.hatcocorp.com



24 Hour 7 Day Parts and Service
Assistance available in the United States
and Canada by calling 800-558-0607.