

# AMERICAN RANGE

Chef Inspired, Professional Cooking Equipment

## Culinary Series

### AF-50 HE HIGH EFFICIENCY FRYER

#### STANDARD FEATURES

- Stainless Steel high quality construction.
- Stainless steel durable double layer access door.
- 304 stainless steel fry pots for long life.
- Stainless steel side panels.
- Millivolt control system, no electrical hook up required.
- Thermostatic control adjusts from 200°F to 400°F.
- 100% safety gas shut off when temperature exceeds safe limit.
- 3/4" NPT gas inlet in rear of unit.
- Chrome plated catch rack under the fry baskets.
- 3/4" diameter opening drain valve for easy draining of oil.
- Twin chrome plated fryer baskets with cool grip plastic coated handles for safety & ease.
- 6" high chrome plated adjustable legs.
- Regulator with built-in gas valve.
- Deflector/baffles absorb and diffuse heat to tube walls, providing fast and efficient heating.
- Combination gas valve includes built in pressure regulator, and gas control system, hermetically sealed for operating stability.
- **High Efficiency Power** - 3 each 25,000 BTU's/hr. Burners (total 75,000 BTU's)
- 50 Lb tank oil capacity
- High-Limit Safety Switch Standard
- Two year limited warranty, parts and labor.

#### OPTIONAL FEATURES

- Stainless Steel tank cover.
- Casters (2 locking).
- Matching "Dump Station".
- Stainless steel splash guard (removable & tool-less).
- Heat lamp for model #ARFDS, Stainless Steel work top/side tray.
- Stainless Steel side tray with pan & cut out.
- Stainless Steel Spreader work top solid surface. 12", 18" & 24".
- Quick disconnect and flexible gas hose.



GAS TYPE:  NATURAL  LP



**Model Shown AF50-HE**  
Casters are optional.

**High-Efficiency Power**  
3 each 25,000 BTU's/hr.  
Burners (total 75,000 BTU's)

You get a faster and better fryer The **Culinary Series** by American Range, with the latest technology incorporated into its design, and tons of features and benefits to suit the everyday demanding needs especially during extreme operating periods. Bringing added value and assured performance, by offering superior recovery. The ample cool zone prevents food particles from carbonization while extending oil life. Our unique vessel tank design features a deeper oil level, for larger food products, and a sloping vessel bottom for quick and complete draining of oil and debris.

Its special design tube shields provide a uniform heating pattern for positive, more consistent frying results. Equipped with a Millivolt Control System, and a 100% safety shut off valve. No electrical power is required. Conveniently located controls for easy access for operators, maintenance and service. All Stainless Steel heavy duty exterior. Durable, double panel door, rugged base and removable Stainless Steel basket guide. Equipped with two nickel plated baskets with cool grip plastic coated handles provide maximum operator comfort.

Quality, dependability and customer satisfaction make American Range the **brand of choice among professional chefs and restaurateurs worldwide.**

# Culinary Series

## AF-50 HE HIGH EFFICIENCY FRYER

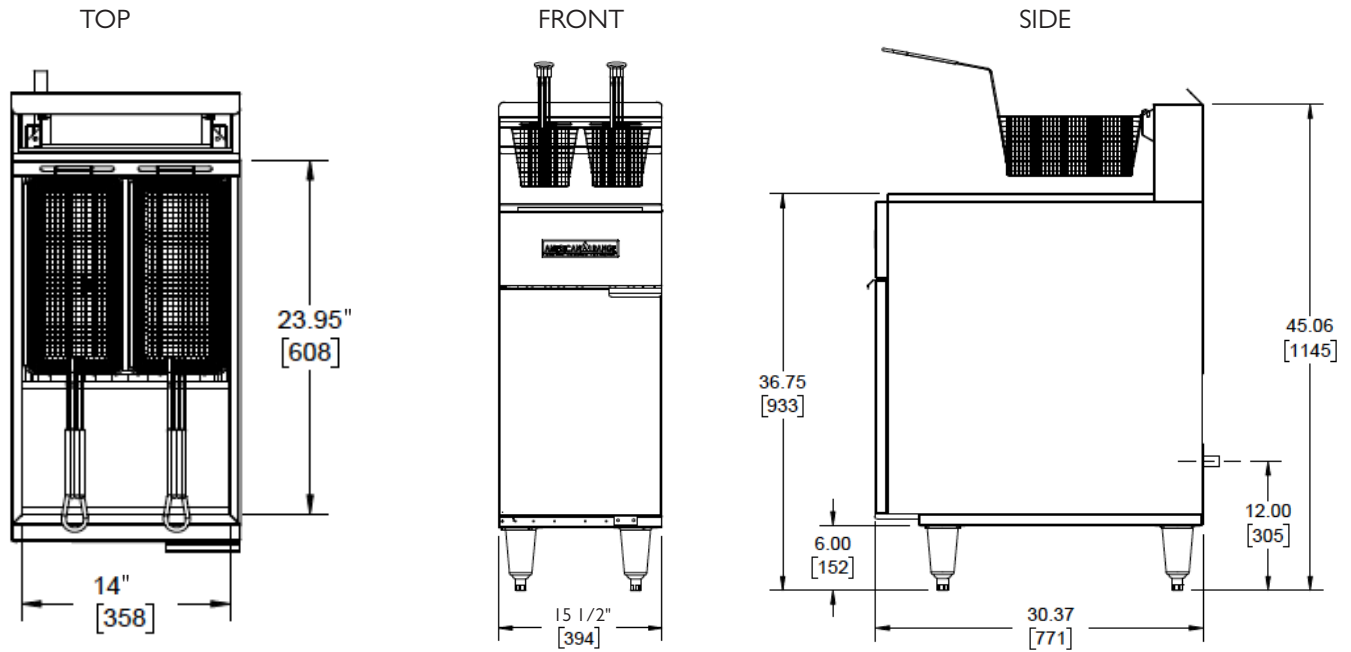

Model	Total BTU	KW	Width	Depth	Height	Cooking Area	No. of Burners	Shipping Weight	Lbs.	Kg.
AF50-HE				Full Size S/S Fry Pot						
50lbs.	75,000	22	15 1/2"	30 1/2"	45 3/4"	14" x 14"	3		150	68
23kg.			(394mm)	(788mm)	(1162mm)	(356 x 356mm)				

### FEATURES

- High-Efficiency Power 3 each 25,000 BTU's/hr. Burners (total 75,000 BTU's)
- 50 Lb tank oil capacity
- Fryer vessel tank: All Stainless Steel high quality construction, 16 gal. #304 material.
- Exterior: All Stainless Steel front, door and basket hanger/flue riser.
- Stainless Steel Door: Durable double layer access door
- Basket Hanger: Removable basket hanger accommodates a large fryer basket.
- Fryer Baskets: Nickel plated fryer basket with cool grip plastic coated handle for operator safety and ease.
- Millivolt control system: No electrical hook up required.
- Thermostatic Control: Thermostat adjusts from 200°F to 400°F.
- Safety shut-off System: 100% gas shut off if oil temperature exceeds safety limit.
- Combination Gas Valve: Includes pressure regulator and gas control system, hermetically sealed for operating stability. 1/2" NPT gas inlet in rear.
- Crumb Screen: Large removable nickel plated screen under fryer basket.
- Drain Valve: 3/4" (32) diameter opening for easy draining of oil, and plastic coated handle for safety.
- Legs: 6" (157) high chrome plated adjustable legs.

### OPTIONAL FEATURES

- Casters: 6" (152) high casters front two with locking brakes.
- Tank Cover: Stainless Steel cover to fit over tank vessels.
- Joiner Strip: Connects two fryers and prevents oil from getting in between the fryers or drain station.
- Quick Disconnect: Flexible Gas Hose has restraining device for added safety.
- Dump Station: Stainless Steel dump station with door and convenient cabinet below.
- Stainless Steel side tray for working surface or dump station, can be used with optional heat lamp.
- Stainless Steel Splash Guard (removable and tool-less).

**GAS SUPPLY:** 3/4" NPT Gas inlet. Manifold pressure is 4.0" W.C. for natural gas or 10.0" W.C. for propane gas. Specify type of gas and altitude if over 2000 feet.

**CLEARANCES:** For use only on non-combustible floors. Legs or casters are required, or 2" (51 mm) overhang is required when curb mounted. Clearance from non-combustible walls is 0". When unit is placed next to combustible walls, clearances must exceed 12" (305 mm) on sides, and 4" (102 mm) from rear.

American Range is a quality manufacturer of commercial cooking equipment. Due to continuing product improvements, these specifications are subject to change without prior notice.