



Item # _____

Job _____



Metro C5 1 Series Non-Insulated Heated Holding and Proofing Cabinets

- **Control:** Three holding modules are available. All feature an easy-to-read digital thermometer, recessed control dials, a master on/off switch, and power indicator lights.
 - **Combination Module:** At the flip of a switch change from heated holding mode to proofing mode. Individual analog controls for temperature and humidity levels.
 - **Holding Module:** For heated holding applications. Analog temperature control and a passive humidity generation system.
 - **Proofing Module:** For proofing applications only. Individual analog controls for temperature and humidity levels.
- **Performance:** All modules provide fast heat-up and recovery through a thermostatically controlled, forced air heating system.
- **Sizes:** C5 1 Series cabinets are available in Full Height (69³/₄" , 1772mm), ³/₄ Height (57³/₄" , 1467mm), and ¹/₂ Height (42³/₄" , 1086mm) sizes.
- **Doors:** Clear polycarbonate doors provide visibility of the contents of the cabinet without the heat loss associated with opening the door.
- **Capacity:** Three slide styles provide maximum holding capacity.
 - **Universal:** Adjustable wire slides, with SiteSelect™, hold 18"x26" sheet, 12"x20" steam table, 2/1 or 1/1 GN pans, and adjust on 1¹/₂" (38mm) increments.
 - **Lip Load:** Fixed aluminum extrusions hold 18"x26" sheet pans on 1¹/₂" (38mm) increments.
 - **Fixed Wire:** Fixed slides hold 18"x26" sheet table, 2/1 GN, or 1/1 GN pans on 3" (76mm) increments.
- **Removable Module:** All modules are removable, without tools, for easy cleaning of the cabinet interior. Future module upgrades or changes can occur without cabinet body replacement.
- **Reliability:** Reliability and durability are designed into every C5. High quality components provide a long life of worry-free use.



Full Height
Fixed Slides
Holding Module



¹/₂ Height
Fixed Slides
Combination Module



³/₄ Height
Fixed Slides
Combination Module

C5 1 Series Non-Insulated Heated Holding and Proofing Cabinets

13-91



1 Series Removable Control Modules

- **Holding Module:** Hot holding at higher temperatures without moisture control.
- **Proofing Module:** Proofing at lower temperatures. Heat and moisture control for proofing applications.
- **Combination Module:** Hot holding and proofing. Moisture control at lower temperatures (proofing).



InterMetro Industries Corporation
North Washington Street
Wilkes-Barre, PA 18705
www.metro.com





C5 1 Series Non-Insulated Heated Holding and Proofing Cabinets

Specifications

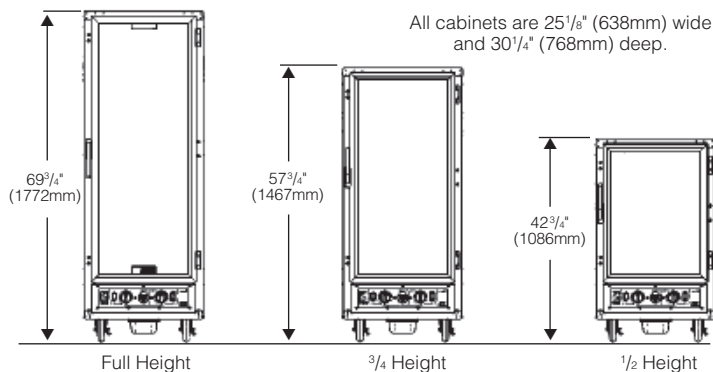

- Cabinet Material:** .063" (1.8mm) aluminum, natural interior, brushed exterior with .125" (3.2mm) aluminum chassis.
- Casters:** Four casters with 5" (127mm) donut neoprene wheel, double ball bearing swivel, ball bearing axel, nickel plated, two with brake.
- Clear Doors:** Extruded aluminum powder coated frame with .090" (2.3mm) polycarbonate window.
- Hinges:** Field reversible, double hinged, 180° swing, with long-life nylon bearings.
- Gaskets:** High temperature, door mounted, Santoprene gaskets.
- Latches:** Polymer, high-strength, magnetic pull latch with lever-action release.
- Universal Slides:** 1/4" (6.4mm) dia. nickel-chrome electroplated wire, adjustable on 1 1/2" (38mm) increments.
- Lip Load Slides:** 1 1/2"x1 1/2"x.063" (38x38x1.8mm) extruded aluminum channel slides, 1 1/2" (38mm) fixed spacing.
- Fixed Wire Slides:** 1/4" (6.4mm) dia. nickel-chrome electroplated wire, welded on 3" (76mm) spacing.
- Drip Trough:** Smooth polymer drip trough with catch pan.
- Holding Modules:** Removable without tools, digital thermometer, recessed control dials, master on/off switch, "Power On" light, water pan, ball bearing blower forced air system, 7 1/2' cord, UL, CUL, and NSF Listed.

Electrical and Performance:

- Combination Module:** 2000 Watt, 120 Volts, 60 Hz., single phase, 16.7 Amps. 80°F to 190°F operating temperature range. 95% RH at 95°F. NEMA 5-20P plug.
- Holding Module:** 2000 Watt, 120 Volts, 60 Hz., single phase, 16.7 Amps. 80°F to 190°F operating temperature range. NEMA 5-20P plug.
- Proofing Module:** 1440 Watt, 120 Volts, 60 Hz., single phase, 12 Amps. 80°F to 120°F operating temperature range. 95% RH at 95°F. NEMA 5-15P plug.
- Slide Capacities:**

Cabinet Size	Universal Wire Pan Capacity**				Lip Load Pan Capacity		Fixed Wire Pan Capacity	
	Slide Pairs Provided		18"x26"	12"x20"x2.5" GN 1/1	18"x26"	18"x26"	12"x20"x2.5" GN 1/1	
Full Height	18	37	18	34	35	18	34	
3/4 Height	14	29	14	26	27	14	26	
1/2 Height	8	17	8	16	17	8	16	

*Maximum number of slide pairs @ 1 1/2" spacing. Additional slide pairs ordered separately.
 **Capacity based on standard number of slides provided.

Cabinet Height
 9 = Full Height
 7 = 3/4 Height
 5 = 1/2 Height

Module Type
 C = Combination
 H = Heated Holding
 P = Proofing

Slide Type
 U = Universal Wire
 4 = Fixed Wire
 L = Lip Load Aluminum

C5 19 - CFC - U

- For Combination and Holding Module Cabinets (120V, 16A, 60Hz, 2000W)
NEMA 5-20P
- For Proofing Module Cabinets (120V, 12A, 60Hz, 1440W)
NEMA 5-15P
- Door Style
FC = Full Length Clear

Export Model Number Description

C5 19 - CXFC - U

- Add "X" for Export Cabinets
- For Combination and Holding Modules (220-240V, 7.6-8.3A, 50/60Hz, 1681-2000W)
NEMA 6-15P
- For Proofing Modules (220-240V, 5.5-6A, 50/60Hz, 1210-1440W)

Models with Accessories or Options

C5 19 - CFC - UA

An "A" suffix indicates that accessories need to be factory assembled to the cabinet. Order accessories separately.

Options/Accessories

- Small Item Shelf (C5-SHELF-S)
- Stainless Steel Legs (C5-SSLEGS)
- Universal Slide Pair, Chrome (C5-USLIDEPR-C)
- 6" Casters (C5-6CASTER)
- Rear Rigid Casters (C5-5RDGCSTR)
- Travel Latch (C5-TRVL)
- Flush Door Latch (C5-LATCHFLUSH-1)
- Rear Push Handle (C5-RHANDLE)
- Perimeter Bumper (C5-PERMBUMP-1)
- Straight Plug, 20 Amp, 120V (C5-STRPLG-20)
- Straight Plug, 15 Amp, 120V (C5-STRPLG-15)
- Factory Left-Hand Hinging (DD3768)
- Stainless Steel Universal Slides (please call)

Metro Heated cabinets are for hot food holding applications only.

All Metro Catalog Sheets are available on our website: www.metro.com



InterMetro Industries Corporation

North Washington Street • Wilkes-Barre, PA 18705 • 570.825.2741
 Fax: 800.638.9263 (East Coast/Canada) • Fax: 800.638.3292 (West Coast)

FOR PRODUCT INFORMATION/CUSTOMER SERVICE:
 U.S./Canada/Latin America: 1.800.992.1776 • Europe: +31.76.587.7550
 Asia/Pacific: +65.6567.8003 • Middle East/Africa: +971.4.811.8286

Information and specifications are subject to change without notice. Please confirm at time of order

L03-269
 Rev. 05/12
 Printed in U.S.A.

Copyright © 2012 InterMetro Industries Corp.