

so ir

FRYING

CONCEPT



COUNTERTOP FRYERS

- Fast heat rise
- Easy to disassemble for cleaning
- Night cover to keep the fryer clean
- Built-in safety thermostat
- Stainless steel construction
- Baskets are fitted with heat resistant handles

SMALL FRY

RF5S

120 V

Compact Design - Big Taste



OIL CAPACITY:
10 lbs / 1 basket
FRIES OUTPUT:
up to 22 lbs / hr

FRY RITE

RF8SP

208/240 V

Portable Commercial Fryer



OIL CAPACITY:
15 lbs / 1 basket
FRIES OUTPUT:
up to 40 lbs / hr

MIGHTY MAX

RF12SP

208/240 V

Compact Professional Fryer



OIL CAPACITY:
25 lbs / 1 or 2 baskets
(specify when ordering)
FRIES OUTPUT:
up to 50 lbs / hr



765 WESTMINSTER STREET PROVIDENCE, RI 02903
TEL: (401)273-3300 FAX: (401)273-3328 E-mail: sales@equipex.com
www.equipex.com



COUNTERTOP FRYERS

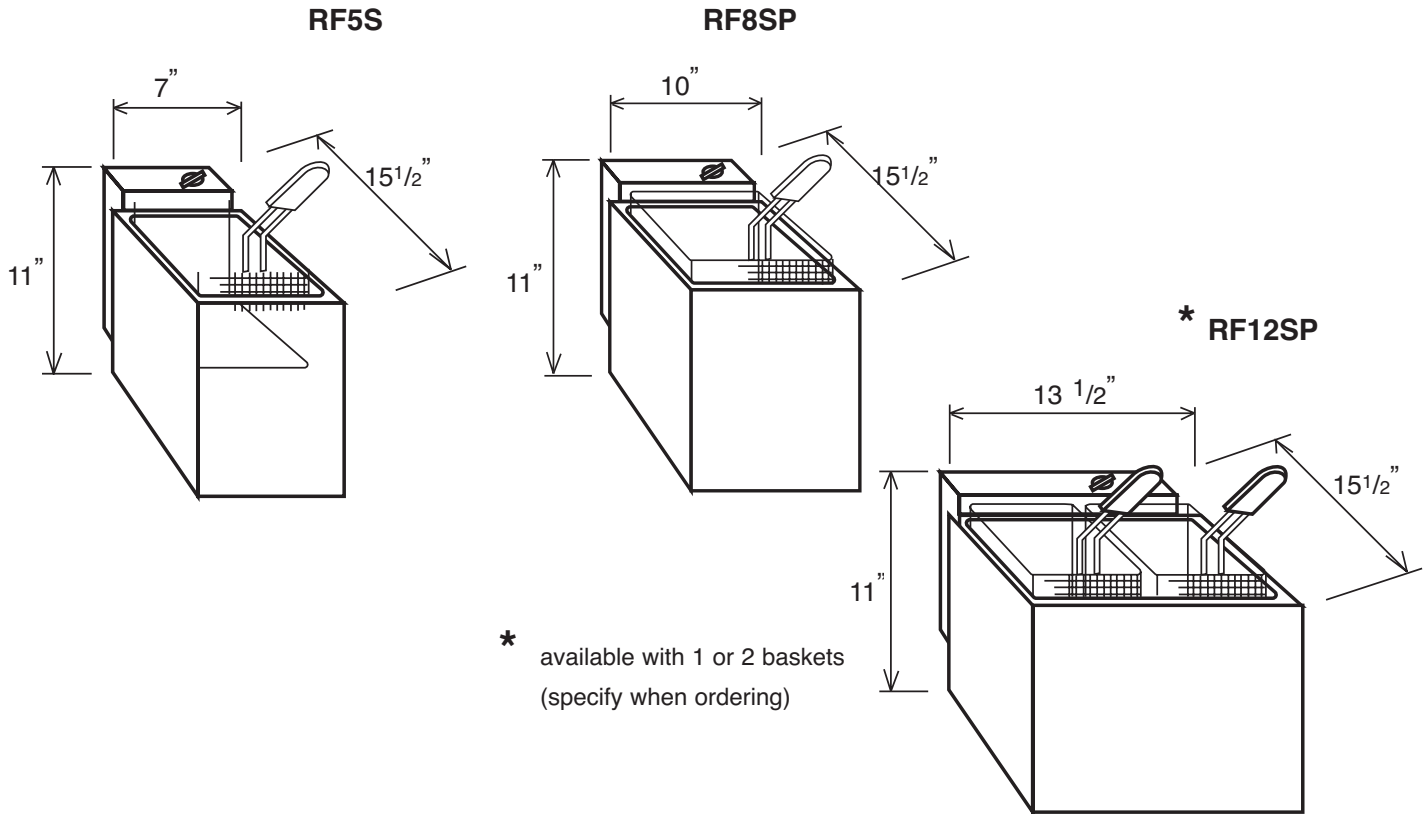

SPECIFICATIONS

MODEL	ELECTRICAL	DIMENSIONS	SHIPPING WEIGHT	NEMA PLUG
RF5S	120V, 1.75KW, 15 Amps	7"Wx15 1/2"Dx11"H	12 lbs	5-15 P
RF8SP	208/240V, 1PH, 5KW, 22/24 Amps	10"Wx15 1/2"Dx11"H	16 lbs	L6-30 P
RF12SP	208/240V, 1PH, 6.5KW, 28/31 Amps	13 1/2"Wx15 1/2"Dx11"H	22 lbs	6-50 P

WARRANTY: Limited one year parts and labor



765 WESTMINSTER STREET PROVIDENCE, RI 02903
 TEL: (401)273-3300 FAX: (401)273-3328 E-mail: sales@equipex.com
 www.equipex.com