



WARMING DISPLAYS

CONCEPT

COUNTER TOP FULL SIZE WARMING DISPLAYS

Fully panoramic and illuminated full size display showcase

- Ventilated fire stone heating system: 68°-194°F
- Precise control of temperature with electronic thermostat
- Humidity control to keep products moist and delicious
- LED lighting system (6500°K)
- Hinged glass doors open to angle of 180° on server side
- Fixed glass front and sides
- Stainless steel construction

PANORAMA

WD780-2/1
120V

WD780-2
208/240V



Shown with stainless steel exterior



765 WESTMINSTER STREET PROVIDENCE, RI 02903
TEL: (401)273-3300 FAX: (401) 273-3328 E-mail: sales@equipex.com
www.equipex.com



WD780S-3 shown with (2) extra shelves

FEATURES:

- Electronic thermostat
- On/Off switch, switch for ventilation
- Water container
- Wire shelves
- Will accommodate 18"x26" sheet pans (not included)

EASY CLEANING:

- Shelves and uprights, bottom tray, water pan and fire stone are completely removeable

OPTIONS:

- Stainless steel or black exterior (specify when ordering)
- 1 additional shelf for "-2" models (additional cost)
- 2 additional shelf for "-3" models (additional cost)
- Self-service front (additional cost)

VITRINA

WD780-3/1
120V

WD780-3
208/240V



Shown with black exterior



COUNTERTOP FULL SIZE WARMING DISPLAYS

WD780-2

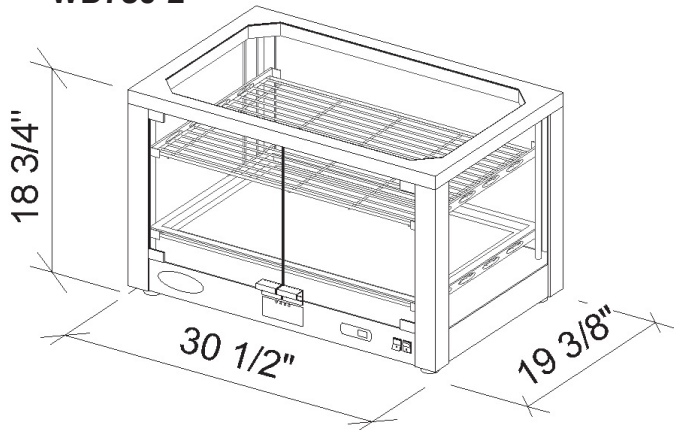

WD780-3

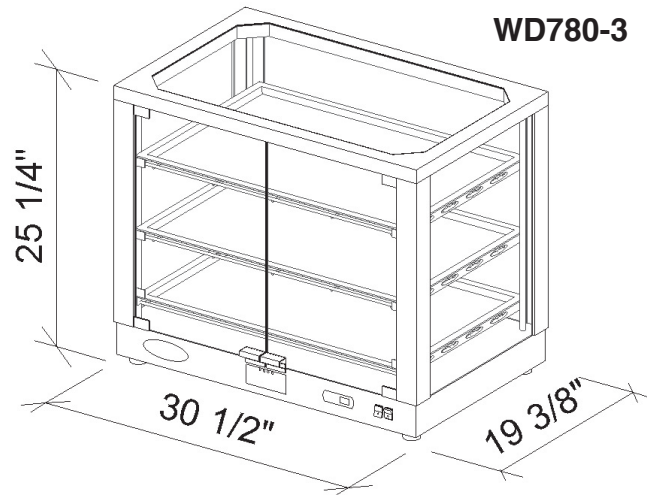

SPECIFICATIONS

MODEL	EXTERIOR FINISH	NUMBER OF SHELVES	CAPACITY (PANS NOT INCLUDED)	ELECTRICAL	OUTSIDE DIMENSIONS L x D x H	INSIDE DIMENSIONS L x D x H	SHIPPING WEIGHT	NEMA PLUG
WD780S-2/1	STAINLESS STEEL	2	(4) HALF SIZE OR (2) FULL SIZE SHEET PANS	120V, 1.75KW 15 Amps	30½" x 19⅝" x 18¾"	29½" x 18¼" x 20⅞"	140 lbs	5 - 15P
WD780B-2/1	BLACK	2	(4) HALF SIZE OR (2) FULL SIZE SHEET PANS	120V, 1.75KW 15 Amps	30½" x 19⅝" x 18¾"	29½" x 18¼" x 20⅞"	140 lbs	5 - 15P
WD780S-2	STAINLESS STEEL	2	(4) HALF SIZE OR (2) FULL SIZE SHEET PANS	208/240V, 1PH 1.2KW, 5/6 Amps	30½" x 19⅝" x 18¾"	29½" x 18¼" x 20⅞"	140 lbs	6 - 15P
WD780B-2	BLACK	2	(4) HALF SIZE OR (2) FULL SIZE SHEET PANS	208/240V, 1PH 1.2KW, 5/6 Amps	30½" x 19⅝" x 18¾"	29½" x 18¼" x 20⅞"	140 lbs	6 - 15P
WD780S-3/1	STAINLESS STEEL	3	(6) HALF SIZE OR (3) FULL SIZE SHEET PANS	120V, 1.75KW 15 Amps	30½" x 19⅝" x 25¼"	29½" x 18¼" x 20⅞"	150 lbs	5 - 15P
WD780B-3/1	BLACK	3	(6) HALF SIZE OR (3) FULL SIZE SHEET PANS	120V, 1.75KW 15 Amps	30½" x 19⅝" x 25¼"	29½" x 18¼" x 20⅞"	150 lbs	5 - 15P
WD780S-3	STAINLESS STEEL	3	(6) HALF SIZE OR (3) FULL SIZE SHEET PANS	208/240V, 1PH 1.8KW, 8/9 Amps	30½" x 19⅝" x 25¼"	29½" x 18¼" x 20⅞"	150 lbs	6 - 15P
WD780B-3	BLACK	3	(6) HALF SIZE OR (3) FULL SIZE SHEET PANS	208/240V, 1PH 1.8KW, 8/9 Amps	30½" x 19⅝" x 25¼"	29½" x 18¼" x 20⅞"	150 lbs	6 - 15P

WARRANTY: Limited one year parts and labor



765 WESTMINSTER STREET PROVIDENCE, RI 02903
 TEL: (401)273-3300 FAX: (401) 273-3328 E-mail: sales@equipex.com
 www.equipex.com