



# WARMING DISPLAYS

## CONCEPT

### COUNTERTOP WARMING DISPLAYS

*Compact heated display units offer panoramic view of merchandise*

- Stainless steel construction
- Concealed fluorescent light fixture and lighted graphics panel on WDL models
- Thermostatically controlled up to 225° F
- Dual service from front and back with lift up doors
- Equipped with water pan for humidity
- Removable bottom crumb tray
- Equipped with lighted switches (WDL Model)
- Raised perforated bottom shelf for superior air flow and product holding

## TUDOR



- \* Two shelves
- \* Exterior dimensions: 24"Wx14"Dx16"H
- \* Shelf size: (2) 21 1/2"Wx13"D
- \* Inside clearance: 5 1/4"
- \* Optional single service door locking device

## WONDER

**WDL-100**

120 V



- \* One shelf
- \* Exterior dimensions: 24"Wx14"Dx12"H
- \* Shelf size: 21 1/2"Wx12 3/4"D
- \* Inside clearance: 6 1/2"

## TOP GON

**WD-100**

120 V



- \* See thru plexiglass top
- \* Same as WDL-100 without light - 9 1/2"H
- \* Stainless steel finish

## GONAGAIN

**WD-200**

120 V

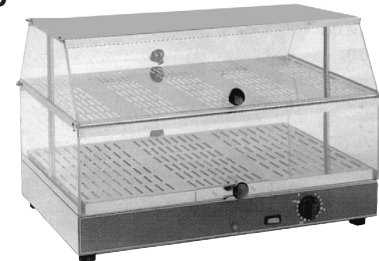

- \* See thru plexiglass top
- \* Same as WDL-200 without light - 14"H
- \* Stainless steel finish



765 WESTMINSTER STREET PROVIDENCE, RI 02903  
 TEL: (401)273-3300 FAX: (401)273-3328 E-mail:sales@equipex.com  
 www.equipex.com



**COUNTERTOP WARMING DISPLAYS**

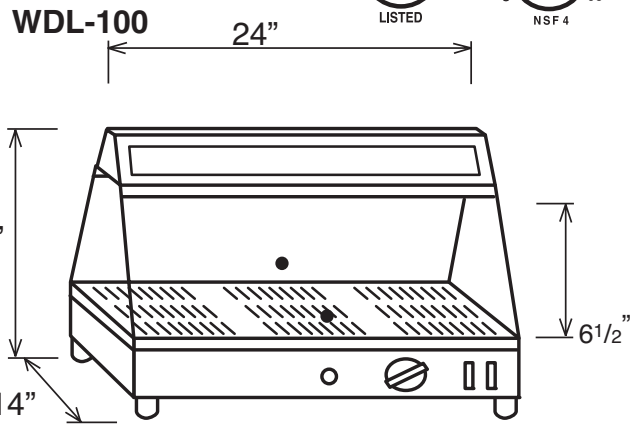
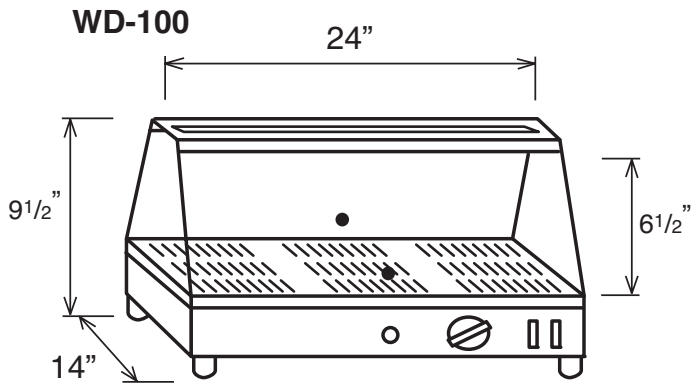

**WDL-200**  
 - Top and bottom shelves hold half size sheet pan  
 - Bottom shelf holds 12"x20" pan

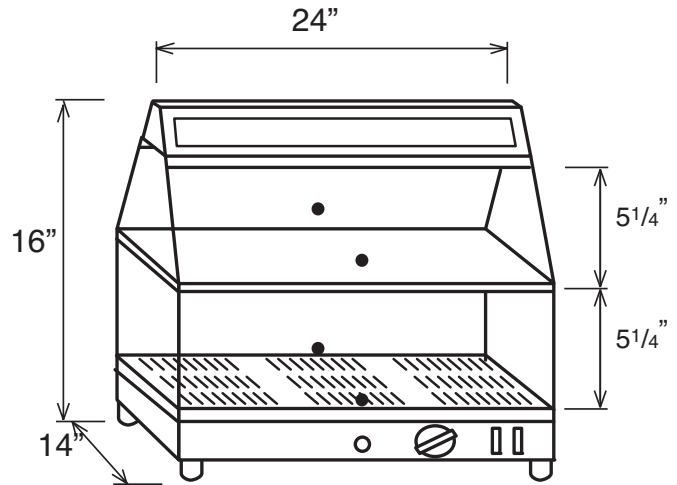
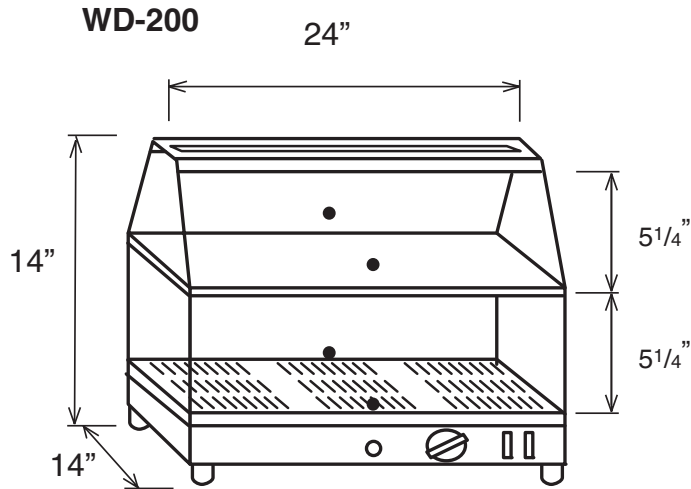

**SPECIFICATIONS**

MODEL	ELECTRICAL	EXTERIOR DIMENSIONS	SHELF DIMENSIONS	SHIPPING WEIGHT	NEMA PLUG
WD-100	120V, 750W, 7 Amps	24"Wx14"Dx9 1/2"H	21 1/2"Wx12 3/4"D	30 lbs	5-15 P
WD-200	120V, 750W, 7 Amps	24"Wx14"Dx14"H	(2)21 1/2"Wx13"D	40 lbs	5-15 P
WDL-100	120V, 750W, 7 Amps	24"Wx14"Dx12"H	21 1/2"Wx12 3/4"D	30 lbs	5-15 P
WDL-200	120V, 750W, 7 Amps	24"Wx14"Dx16"H	(2) 21 1/2"Wx13"D	40 lbs	5-15 P

**WARRANTY: Limited one year parts and labor**



765 WESTMINSTER STREET PROVIDENCE, RI 02903  
 TEL: (401)273-3300 FAX: (401)273-3328 E-mail:sales@equipex.com  
 www.equipex.com