



LARKIN INDUSTRIES, INC.

*Fabricators & Suppliers of
Kitchen Ventilation Products*

Commercial Kitchen Hood

Installation and Maintenance Manual

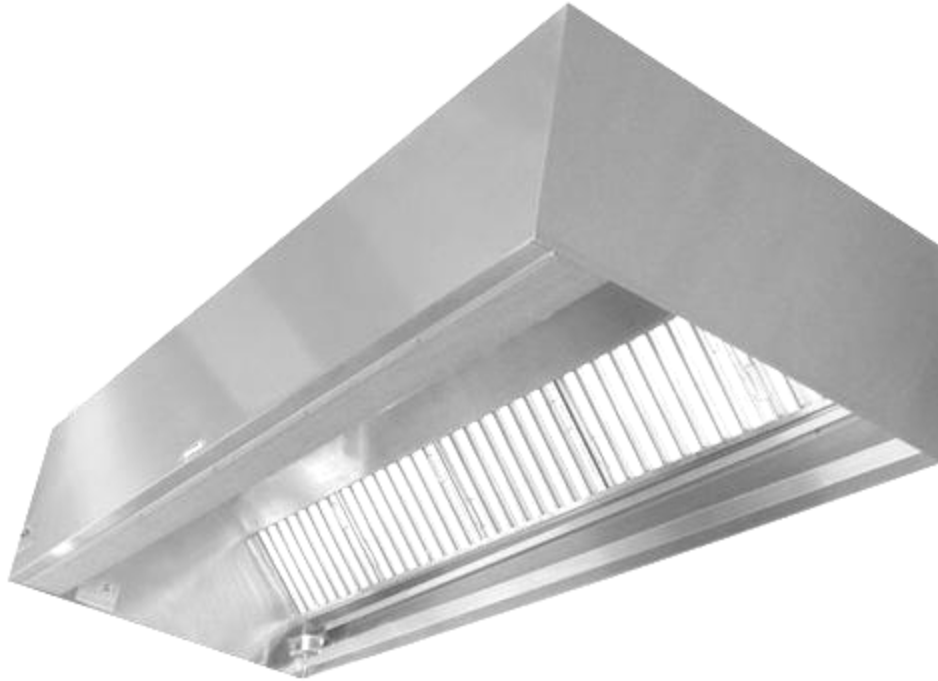

Receiving Shipments

Upon receiving unit, check for any interior or exterior damage, if found, report it to the carrier immediately. Check that all accessory items are accounted for and damage free.

Caution!

We strongly suggest hood Installation should only be performed by a qualified and licensed mechanical contractor who is familiar with the level of involvement for proper installation. Insure proper safety precautions are taken, permits are obtained, and code requirements are met.

Save these instructions. This document is the property of the owner of this equipment and is required for future maintenance. Leave this document with owner after installation or service has been completed.

Table of Contents

- Hood Installation.....1
- Basic Hanging Methods.....2
- End-to-End Hoods.....3
- Back-to-Back Hoods.....4
- Grease Trough and Cup Installation.....5
- Back Return Plenum.....6
- Front Supply Plenum.....7
- Splash Panels.....8
- Ceiling Enclosures.....9
- End Curtains.....9
- Duct Work.....10
- Wiring.....11
- Maintenance.....12
- Warranty.....13
- Trouble Shooting.....14

Hood Installation Instructions

When uncrating, handling, or installing, the installer should exercise extreme caution to protect the stainless steel surfaces from damage, as they are costly to repair.

The installing contractor for the Kitchen Ventilation System is responsible for verifying field measurements of the constructed kitchen area. Consult project plans when determining exact location of the hood(s). Determine how the hood will be hung and prepare the structural support system using inserts, shields, angle iron, etc., and ½" threaded rod with turn buckles (hanging material by others). Verify that the materials used are sufficient to support the weight of hood and hanging system. (Refer to NFPA-96 for proper installation methods and materials.)

All Larkin Industries, Inc. hoods are provided with hanging brackets on top of hood, ½" threaded rod should be used with necessary nuts, washers, etc (see fig. 1). Turnbuckles are recommended for leveling (see fig. 2). Recommended mounting height from bottom edge of hood to the finished floor is 6'-6", (18"-24" from bottom edge of filter to cooking surface for Back Shelf type models). Hoods should be hung level, and where possible, the exhaust outlet should be in line with the exhaust fan opening. Duct runs, offsets, elbows, etc. should be simple and direct as possible (see fig. 3).

When preliminary preparations have been made, prepare the hood for lifting by providing necessary manpower, forklift, crane, duct jacks, etc. Be sure to provide adequate safeguards to prevent damage to the hood, property, and insure safety of personal (see pg 3&4 for multiple section hoods). If a **Back Return (BR)** plenum is provided with the hood, this should be hung first at the standard hanging height (see pg 6). When all hanging material has been attached, lift the

hood in to position and secure to structural framing, leveling the hood by using the turnbuckles. Insure proper tension is placed on each hanging rod for even weight distribution. If the hood has a **Front Perforated Supply Plenum (FPSP)**, this should be installed now (see pg 7). The grease trough needs to be attached to the bottom of filter rail, sloped toward the removable grease container for proper drainage. Attach grease container to the studs at the end of grease trough. Install light bulbs in light fixtures (bulbs by others). Use any well-recognized brand with a maximum of 100 watts.

Install exhaust ductwork. Exhaust duct systems must be continuously welded liquid tight per NFPA-96 requirements. Install supply ductwork (by others) per SMACNA guidelines.

Complete all electrical wiring based on installation wiring diagram provided (by certified electrician).

If hood is manufactured with factory pre-piped fire suppression system, a certified fire system distributor is responsible for final field hookup, testing, and certification of the system. If the hood is not provided with a fire suppression system, a certified fire suppression distributor must be contracted to install, test and certify a fire suppression system (by others).

Protect hood at all times by wrapping it in plastic or other suitable material, until all other work is accomplished and system is ready to be put into operation. Make sure to use stainless steel polish to clean hood. To prevent scratching do not use abrasives on hood.

Warning! Do not penetrate the integrity of the hood grease containment area when hanging hood. Penetrating the grease containment area will void warranty and listing on the hood.

Commercial Kitchen Hood

Basic Hanging Methods

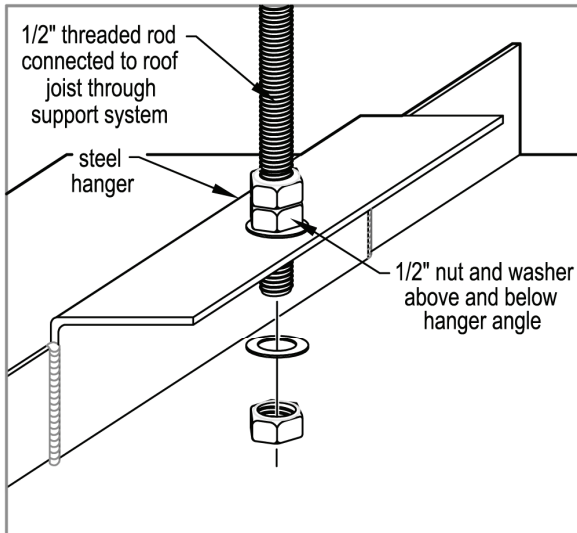

Figure 1
Simple hanging method that requires all thread, two washers, and three 1/2" heavy nuts.

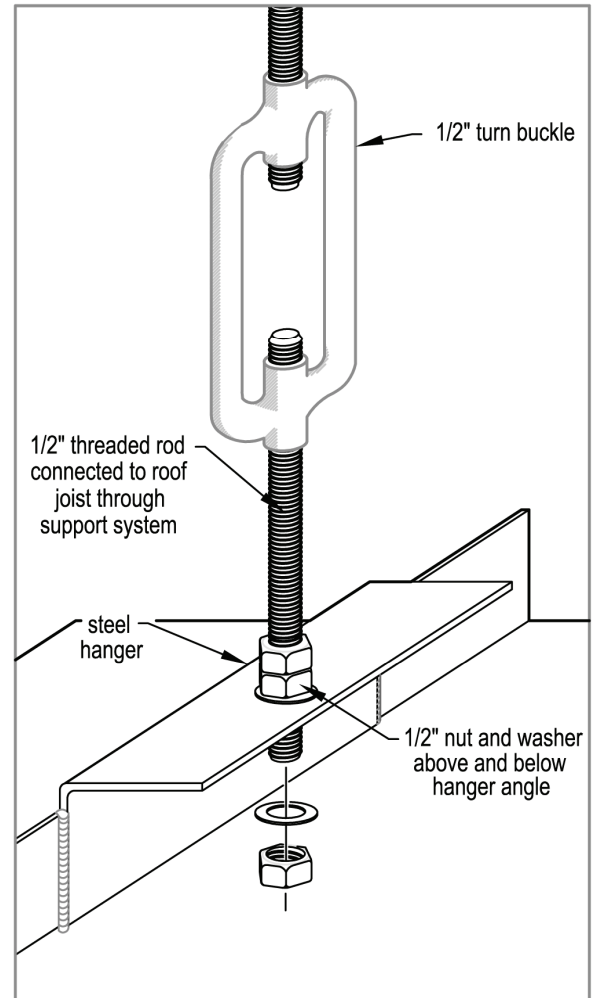

Figure 2
Example of using 1/2" turn buckle designed for easy adjustment of hood level.

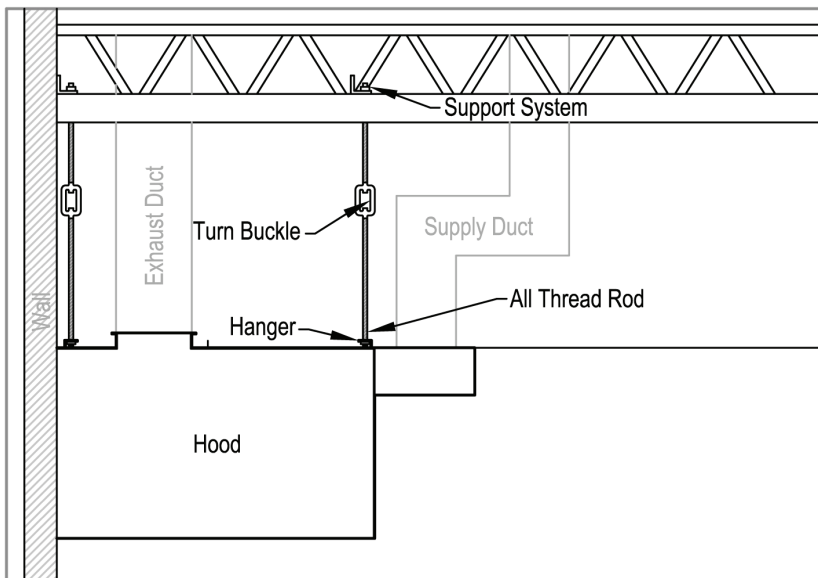
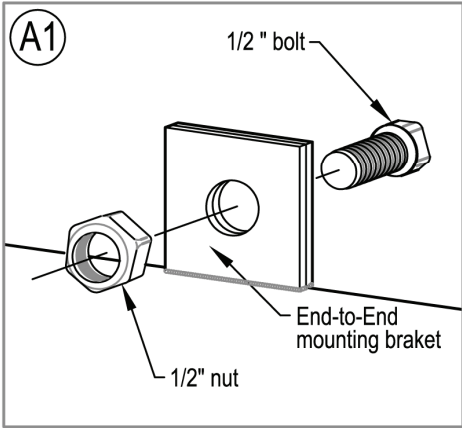
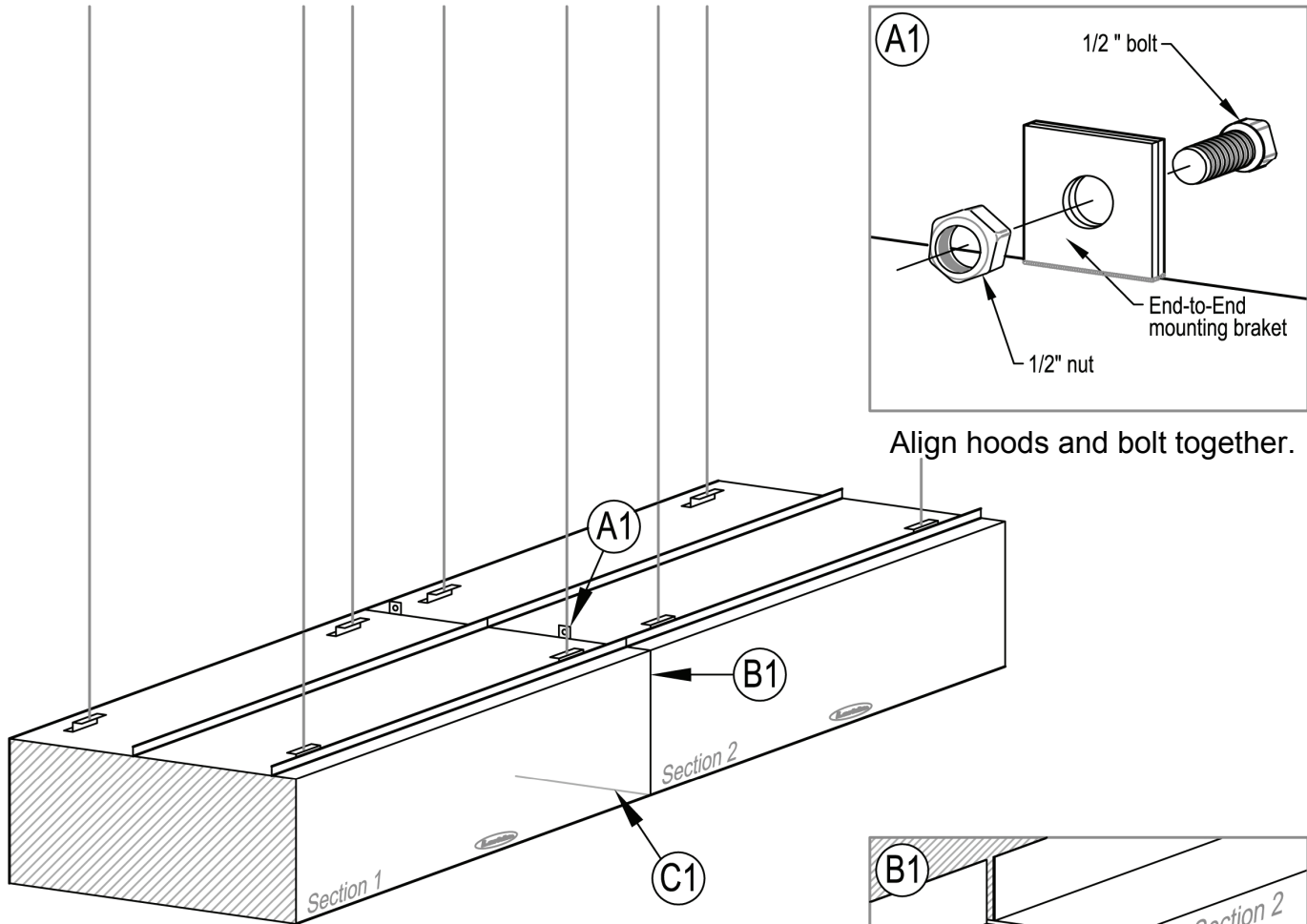

Figure 3
An overview of using turn buckles for hood installation. Methods of hood installations may vary depending on local code requirements.

Note: Hanging material provided by others.

Commercial Kitchen Hood

End-to-End Configuration



Align hoods and bolt together.

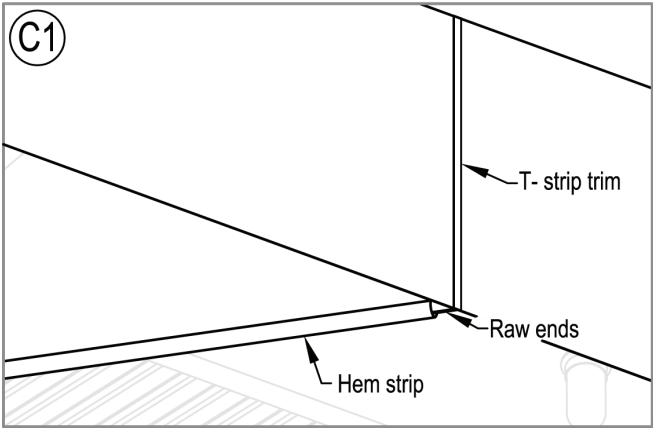
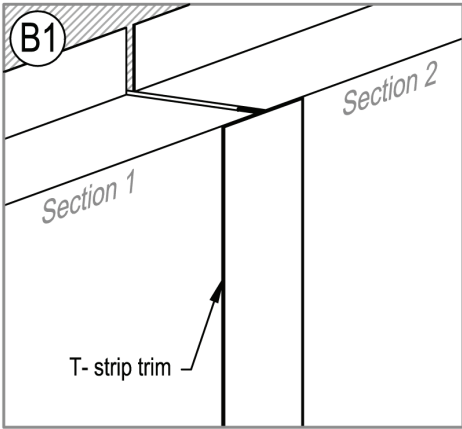

Slide hem strip over raw ends of hood sections and pop rivet in place.

Apply silicone to seam between hood sections. insert "T" strip and temporarily attach with tape. After silicone has dried, remove tape.

Note: Hanging material provided by others.

Commercial Kitchen Hood

Back-to-Back Configuration

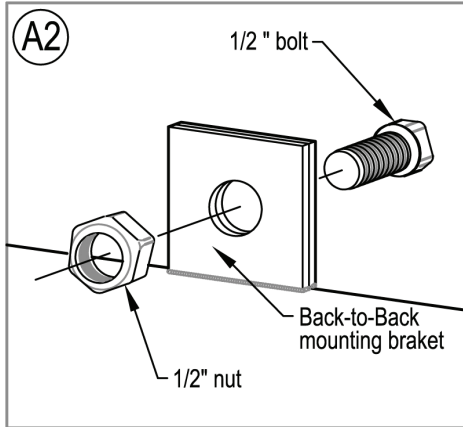

Align hoods and bolt together.

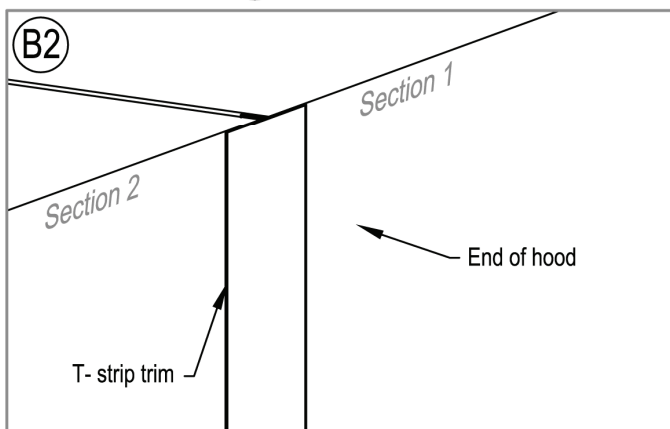
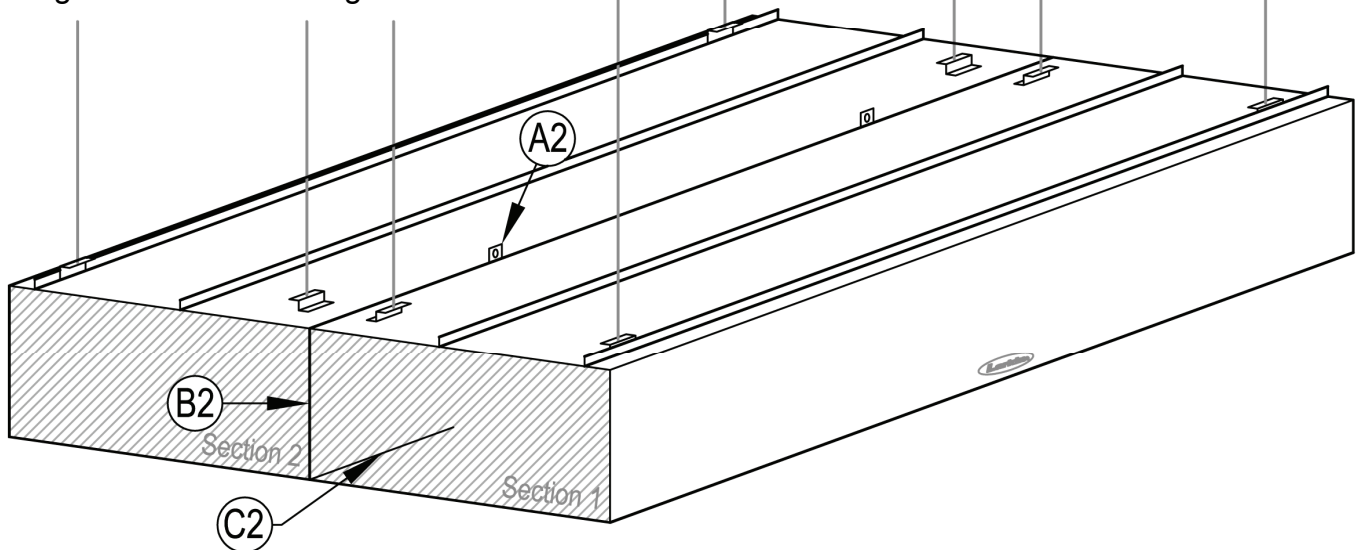

Apply silicone to seam between hood sections. insert "T" strip and temporarily attach with tape. after silicone has dried, remove tape.

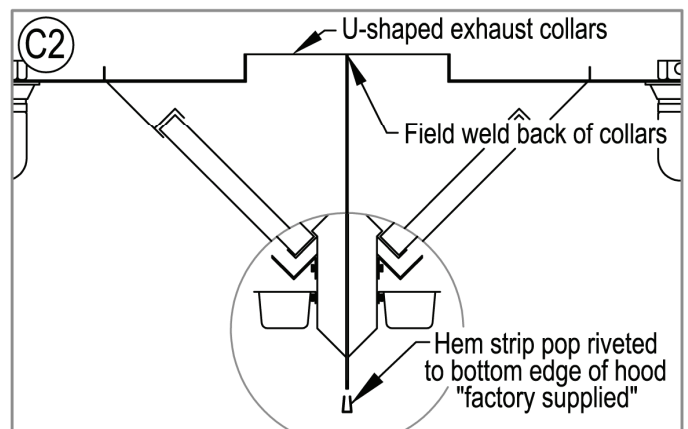

Note: Hanging material provided by others.

Commercial Kitchen Hood

Grease Trough and Cup Installation

NOTICE

No two kitchens are the same and require different schedules of maintenance. Check grease cup daily for the first few weeks of normal operation to determine a proper cleaning schedule. The grease cup will need to be emptied more frequently with heavier cooking loads.

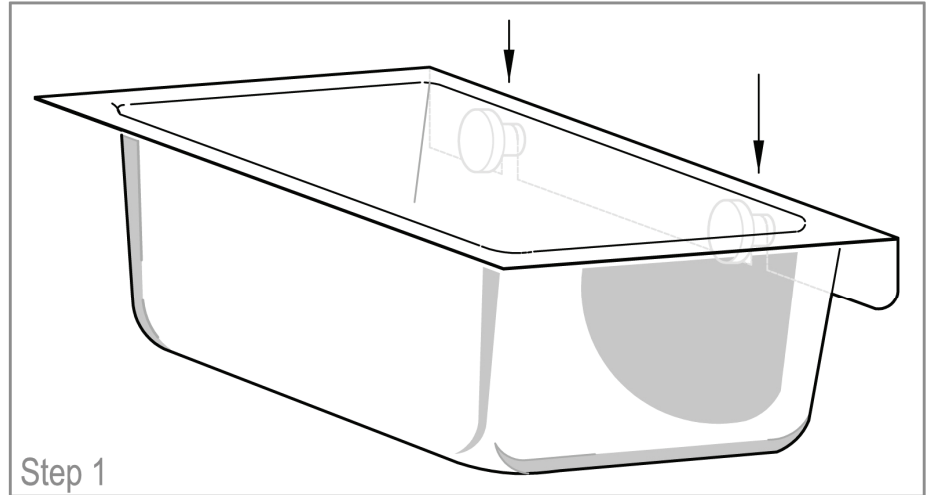

Hang grease cup on the key studs provided below the filter rack.

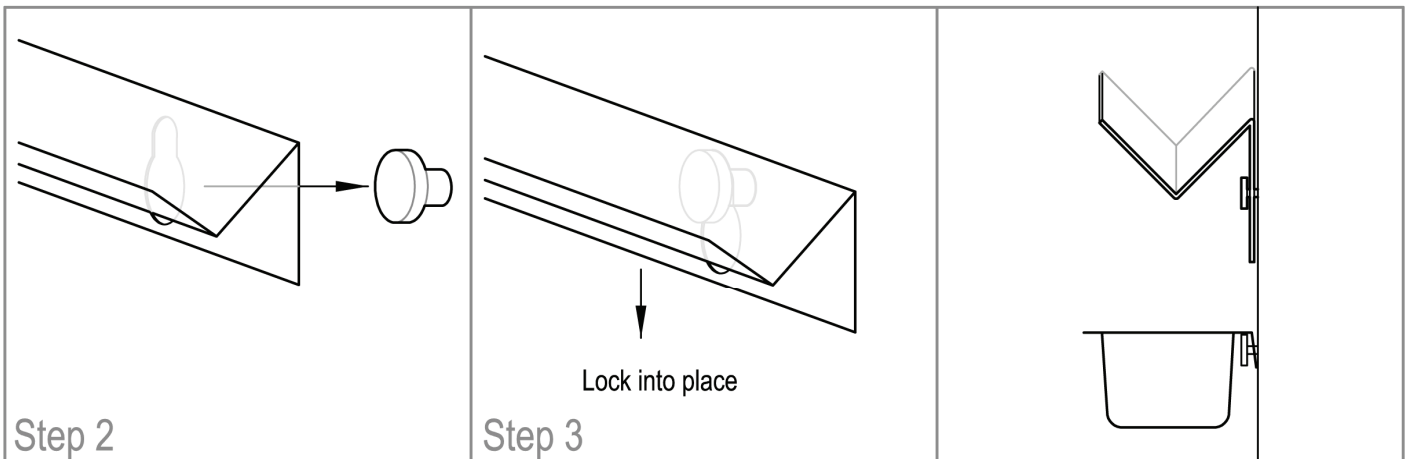

Slide grease trough over the two key studs at an angle with the smaller portion of the keyhole at the top position. Slide trough down to lock into place. Once the trough has been installed, check to make sure it is tilted towards the grease cup shown in the figure below.

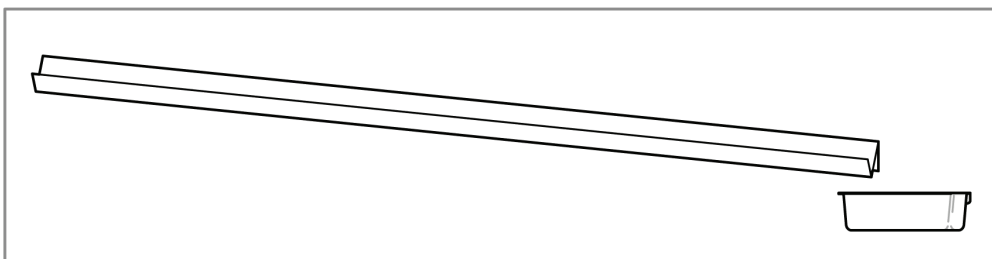

VERY IMPORTANT

Make sure that the small portion of the keyhole is in the up position for proper installation.

Commercial Kitchen Hood

Hood Options 1.1

Back Return Plenum

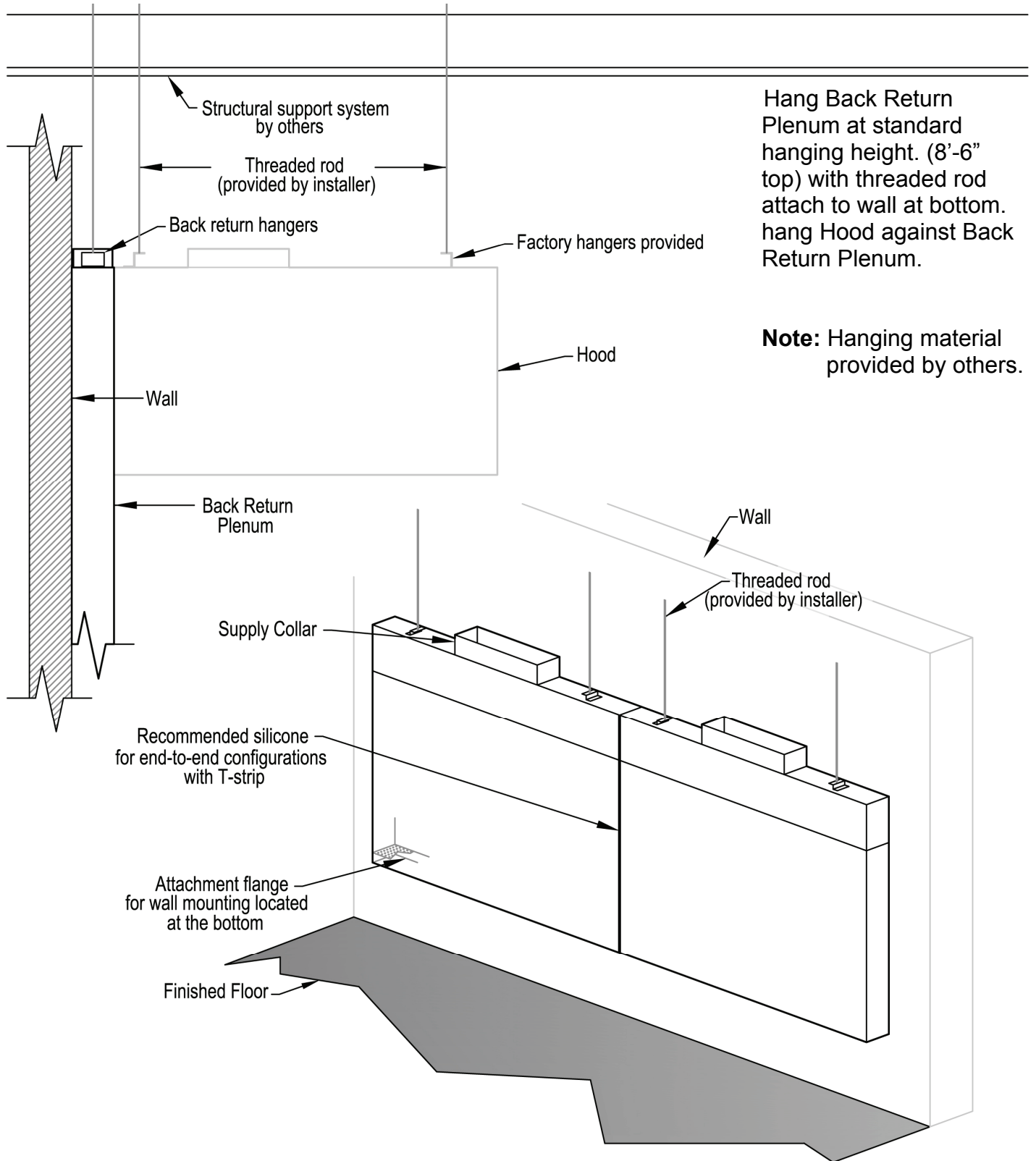

Hang Back Return Plenum at standard hanging height. (8'-6" top) with threaded rod attach to wall at bottom. hang Hood against Back Return Plenum.

Note: Hanging material provided by others.

Commercial Kitchen Hood

Hood Options 1.2

Front Perforated Supply Plenum (FPSP)

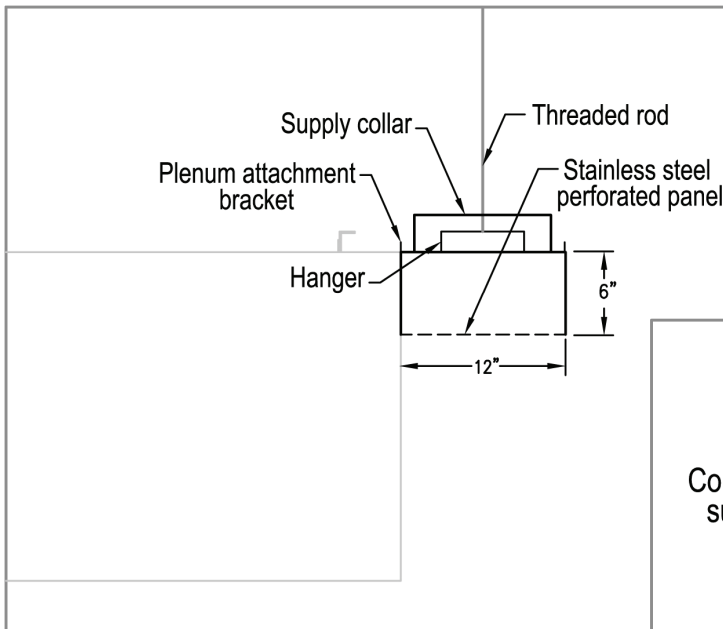
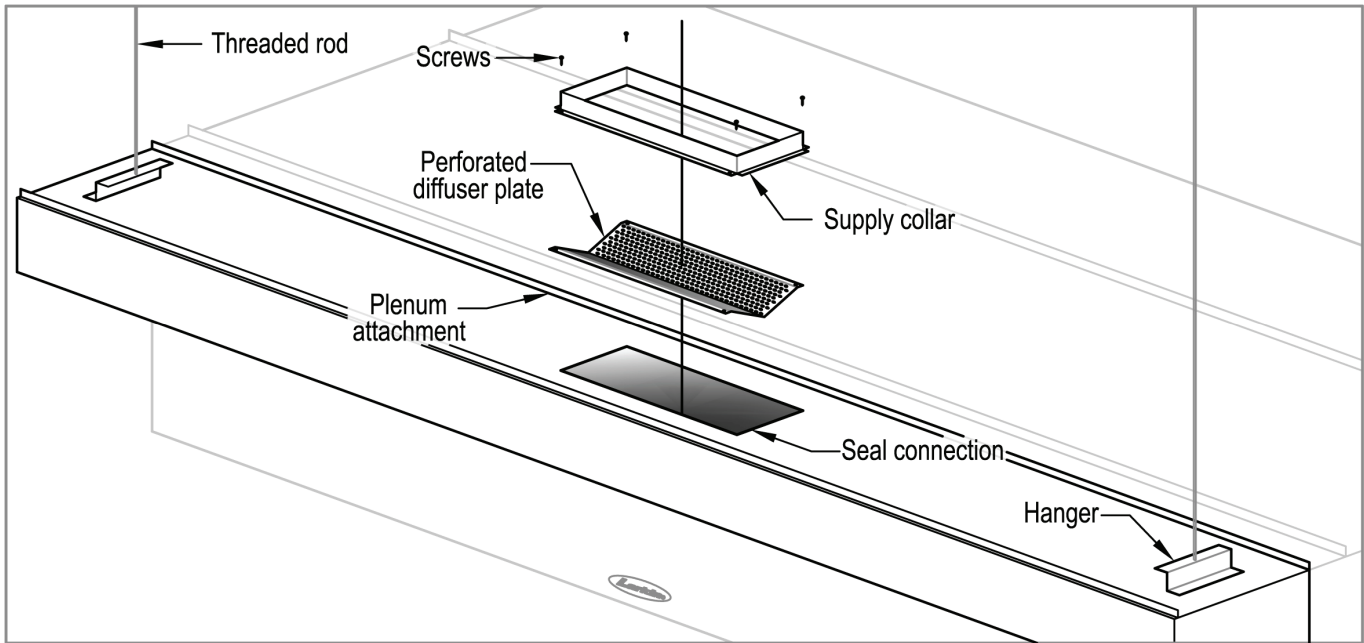

Standard FPSP (12"-16")

Hang FPSP using all thread rod against the upper front of the hood. Attach plenum to channel located on the front edge of the hood. Collars maybe shipped mounted or loose. If the collars are loose, install diffuser plate, attach collar to the plenum, and seal.

Double Discharge (FPSP-AC)

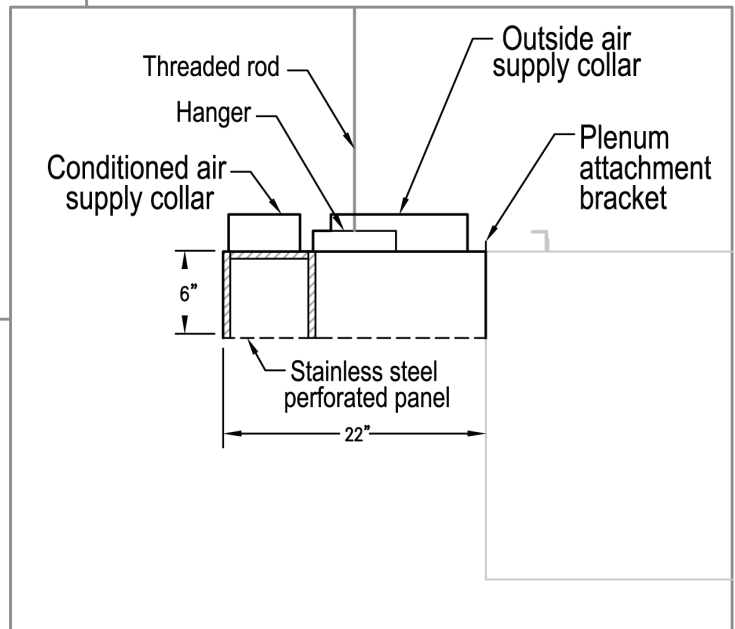

Note: Hanging material provided by others.
Seal collars using approved methods.



Commercial Kitchen Hood

Hood Options 1.3

Stainless Steel Wall Splash Panels

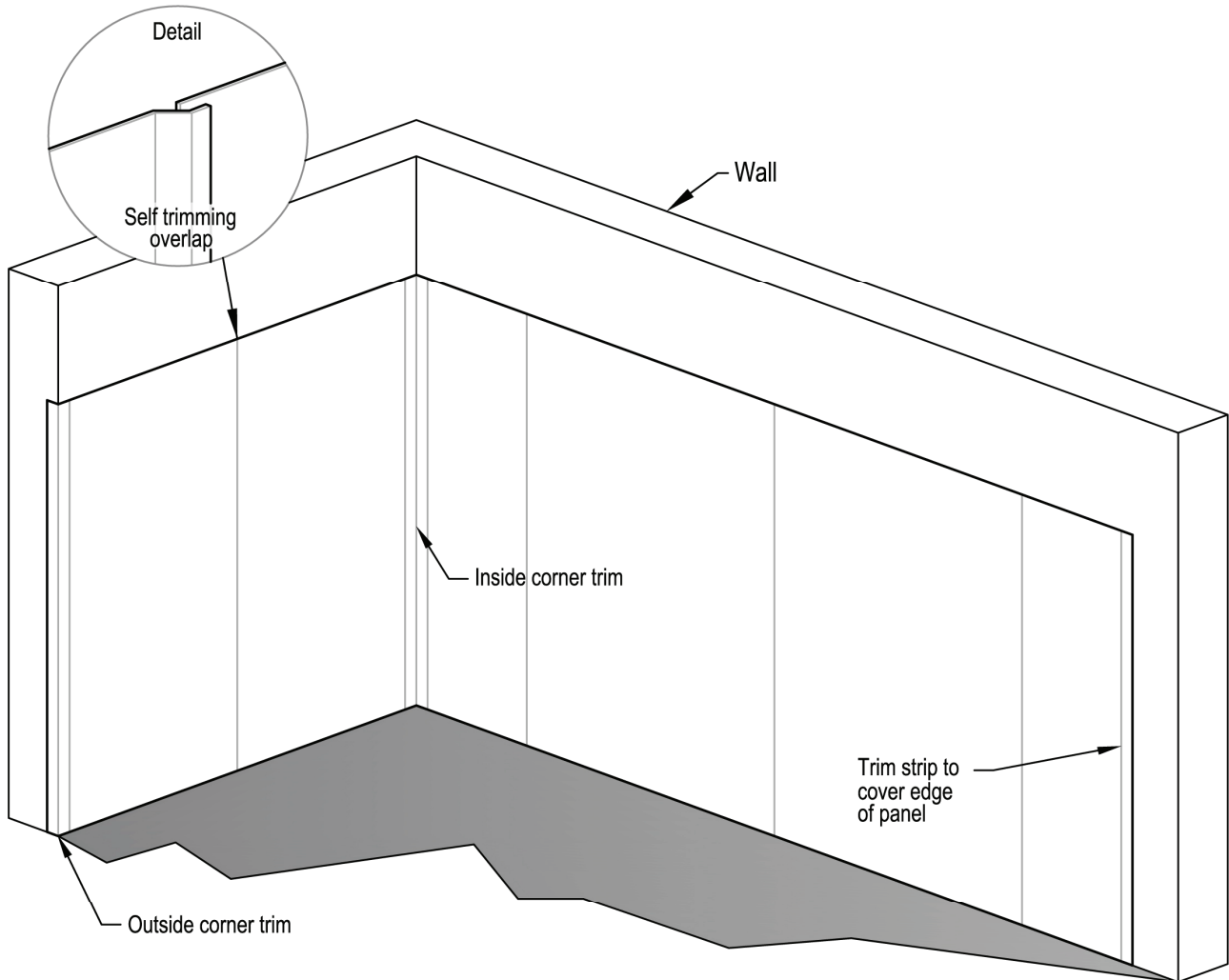

Each overlap reduces the overall length by 3/8". Add the number of overlaps and multiply by 3/8". Divide this measurement by two. Start the first panel (no overlap) at this distance from the end of hood. Install remaining panels using overlap to trim previous panel. Use side trim to extend panels flush with ends of the hood. Inside and/or outside corner trim may also be used. Overlap omitted on one piece wall panels.

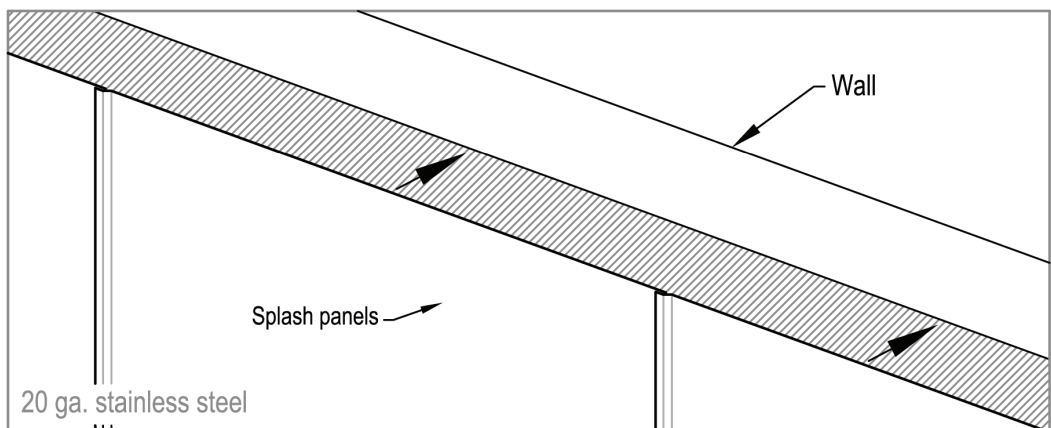

Commercial Kitchen Hood

Hood Options 1.4

Ceiling Enclosure

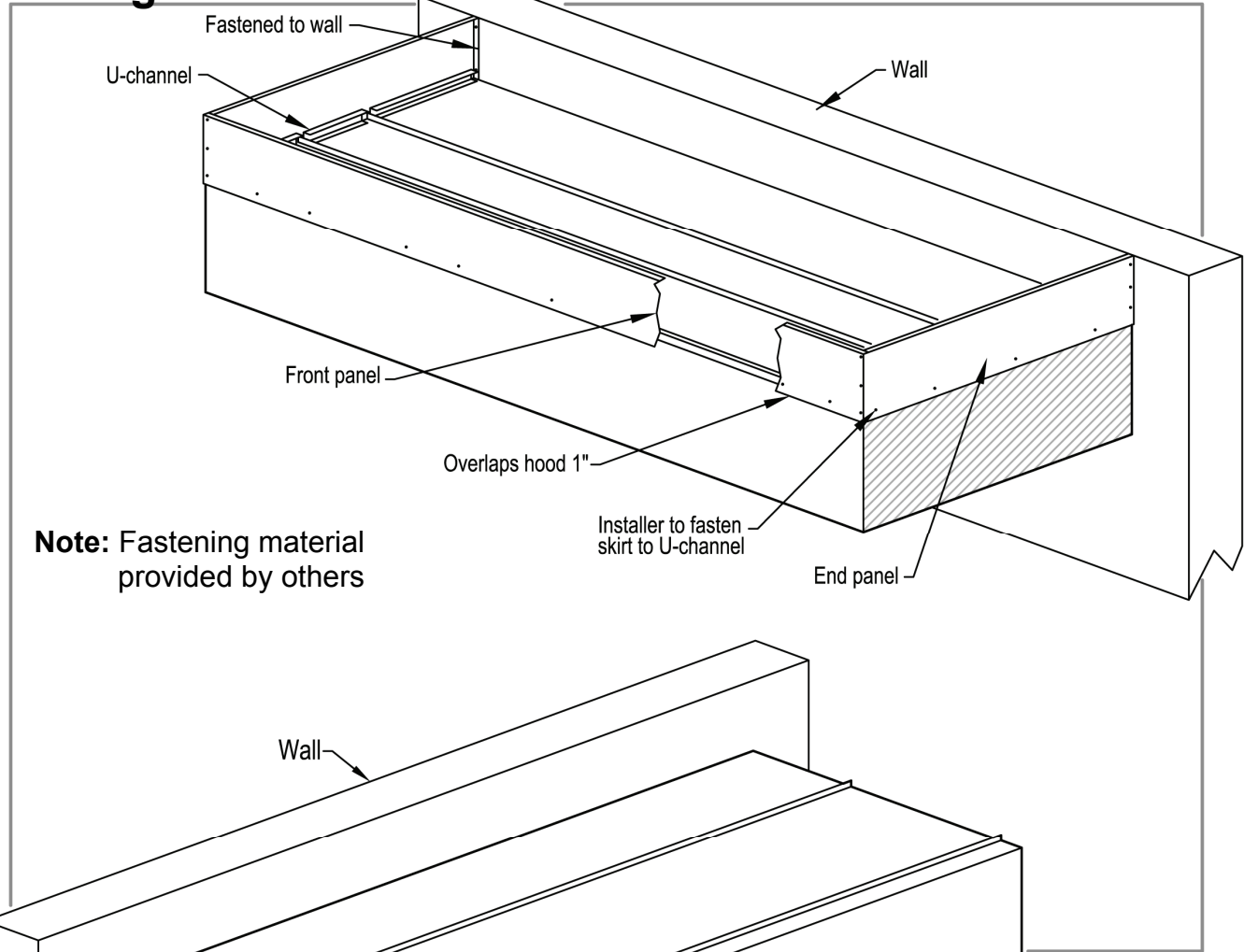

Note: Fastening material provided by others

Installer to fasten skirt to U-channel

End panel

Wall

End Curtains

End panels are manufactured with raw tops

1" Flange

Attach to End of Hood

Attach to the Wall

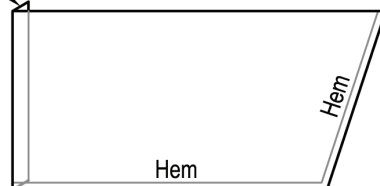

Duct Work

Ductwork Installation

Upon customer request, Larkin Industries, Inc. may furnish ductwork. All ductwork should be installed in accordance with local codes. The installing contractor is responsible for adherence to codes and restrictions. Generally, the duct system will perform best and will insure easy installation if installed in the most direct and simple manner.

NFPA-96 requires that the exhaust duct must be installed using 16-gauge carbon steel or 18-gauge stainless steel with all joints and seams welded liquid tight. Listed factory built grease duct is an exception when installed according to manufactures instructions. NFPA-96 further requires that a **minimum of 500 FPM (Feet Per Minute)** velocity must be maintained in the exhaust duct. There is not a specified maximum; however exhaust velocity should not exceed **2200 FPM**. Install access panels where required. In any event, conformance to local codes must be adhered to, unless variance is obtained.

Make-up air ductwork should contain adequate filtering provisions somewhere in the system before it is introduced into kitchen space, or in the hood. Select hood models require a make-up air fire damper with fusible link installed at the collar. Access to the fusible link must be installed in supply duct. Only use rigid type duct for make-up air. Do not use "flex" duct. This duct should be in accordance with project specifications and installed in accordance with standard SMACNA Low Pressure requirements.

Field Installed Duct Collars

Exhaust and Supply collars are shipped loose (not connected to hood) and intended to be field installed on some projects. Determine the location of exhaust/supply collar(s). Collars

should be located as close to center (left to right) of hood as possible. When two exhaust and/or supply collars are required, equal distance between collars (left to right) should be maintained. Loose collars are tack welded to top of hood (back of crate). Break tack welds to remove collars. Exhaust collars must be folded up before installing. Fire Dampers are shipped loose inside the crate.

Exhaust Collars

When installing exhaust collar(s), cut hole(s) in exhaust plenum as close to center as possible, the size of exhaust collar. Attach collar(s) to the plenum with continuous liquid tight external welds, per NFPA-96. For collar to duct connection see "Exhaust Duct Systems" Chapter 7 of NFPA-96.

Supply Collars

Same as exhaust collar(s), cut hole(s) in make-up air plenum as close to center as possible, 1inch from the front edge of hood, the size of the supply collar(s). Attach collar(s) to hood and seal per local standard for duct connections.

Important: Refer to your **AHJ (Authority Having Jurisdiction)** for requirements and/or questions on local codes.

Clearance to Combustible Materials

A further note on ductwork is important. NFPA- 96 states: "Where 18 in. clearance is required for unprotected combustible material, the clearance may be reduced if the combustible material is protected by an engineered construction system acceptable to the authority having jurisdiction, or by the use of materials or products listed for protection purposes". Consult NFPA-96 and local codes, before installing any hood system or exhaust ductwork.

Wiring and Start-Up

Wiring

A licensed electrician familiar with commercial kitchen hood installation should perform wiring.

Complete all wiring required to controls, lights, fans, etc. When a master control panel is furnished with the hood system, follow the field wiring instructions included with the panel. When master control panel is not furnished, complete in accordance with the project criteria.

Electrical systems should be installed in accordance with **NEC (National Electrical Code)** with disconnecting means, proper fusing and grounding system to protect against hazardous shock.

Start-Up

Determine that the installation is complete and in accordance with the project plans and specifications, that the duct system is complete and that all electrical connections have been made.

Check all motors, coils, etc., for proper voltage and connection. See that all electrical components have adequate accessibility and that all connections are tight. Place the system into operation as provided for in the control sequence.

By physical observation, check the supply and exhaust fans for proper operation by checking voltage, motor overload, noise level, amperage, rotation, etc. Verify that motors and bearings have proper lubrication and that the belts have proper tension. Verify air intake

filters are in place and clean. Make sure inlet damper (if required) is installed in hood

(supply collar) and opened. Airflow in the supply duct should be verified by taking a duct traverse if possible. If this is not possible, the average velocity across the supply nozzle should be taken with a rotating vane anemometer, or other instrument. Determine the supply CFM by multiplying the average velocity by the cross sectional area of the duct in square feet or the net free area of the supply nozzle in square feet.

Capacity of the exhaust system should be determined by a duct traverse if possible and if this is not possible, take an average reading with a rotating vane anemometer across the filter bank. Multiply the average velocity by the cross sectional area of the duct in square feet or by the net free area of the filter bank.

If the airflow, as measured, is not in accordance with the project specifications, adjust the speed of the respective fan(s) as required and re-check (see fan installation instructions).

After the system has been placed in operation and balancing has been accomplished, a visual inspection should be made of the entire system. Inspection should include such things as unusual noises, excessive exhaust or supply air, and general operation.

If smoke is not being exhausted properly, check exhaust fan operation (is it on?). Determine if exhaust air is sufficient. If the air is sufficient, balance the supply air with the damper in the supply collar until all products of combustion are being exhausted. All parts of the system should be left in a clean and polished condition. Always instruct owner/operator in the proper operation maintenance.

Maintenance

Hood

Inspect the grease extractors each day for grease deposits, clean if necessary. Check the grease container every day and empty. Wipe the interior/exterior of the hood daily, if possible, to remove deposits or accumulations of grease. Periodically clean the interior of hood and light fixtures with a mild detergent as necessary.

Scratches on the stainless steel hood can be removed with an abrasive pad (e.g. Scotch-Brite) or similar cloth, being extremely careful to always rub *in the direction* of the metal grain.

After removing any scratches or imperfections, clean the entire hood with a stainless steel polish (e.g. Shiela-Shine). Once polish has been applied, remove excess with a dry cloth.

Caution: *Do not use steel wool pads, scrapers, etc. to clean stainless steel surfaces. Do not use chlorine or chlorine based substances, acids, or chloride based substances on or around the hood. Vapors from these substances can cause corrosion on stainless steel.*

Clean exhaust duct quarterly to prevent grease accumulation.

Notice: If a kitchen ventilation hood is cleaned with pressure-washer or steam cleaner, the silicone sealant will be removed from the sealed seams. Standard daily cleaning over time will loosen the seal and the silicone will be removed from the sealed seams.

The sealant may be replaced, after a thorough cleaning and de-greasing, with a food grade high temperature silicone. Clean grease

extractors daily in a dishwasher or other containers with a mild detergent in warm/hot water. Never use harsh or abrasive cleaners on stainless steel.

Fans

Check cleanliness of supply fan intake filters every two weeks, for the first month, to establish a cleaning schedule. To clean filters, remove supply fan lid, and filters. Flush filters with warm soapy water and recoat with a filter coat adhesive. Reinstall filters and lid.

Check tension of fan drive belts (exhaust and supply) upon initial installation, and again after a period of two weeks of operation. Belts tend to stretch during the initial stages of service. Inspect condition and tension of belts monthly there after. Properly adjusted belt tension will allow approximately 1/2" deflection on each side of the belt, midway between the pulley centers with slight finger pressure. Overly tightened belts will cause wear, motor overloading, bearing wear and noise. Loose belts will cause belt wear, pulley wear, and poor fan performance.

A monthly cleaning of exhaust fan wheel and interior of housing is required. Heavy grease build-up is a fire hazard and can also cause wheels to be unbalanced. This leads to bearing wear, undue noise, and poor fan performance.

Oil and/or grease all motors and bearing every six months or as conditions dictate. At least once a year, check motor and fan shafts. Clean and check tightness & alignment.

At least every six months, all electrical connections should be inspected and checked for tightness.

Warranty

One-Year Warranty

Except for motors (see separate warranty on motors), Larkin Industries, Inc. warrants to its purchaser that each ventilator manufactured by Larkin shall be free from defects in material and workmanship for a period of one year from the date of shipment by Larkin to the original purchaser, if the ventilator has been subjected to normal use and service. If it appears within the warranty period that any such ventilator or material used there in does not meet the warranties specified above, the purchaser must notify the Company immediately. Failure to notify within a reasonable time voids the warranty. The Company agrees to remedy any such defect promptly by either repair or replacement, at the Company's sole discretion of any alleged defective part (exclusive of motors covered separately herein). Cost of installation or removal of any failed unit or part thereof will be the sole responsibility of the purchaser.

This warranty does not guarantee the proper design or installation of any ventilator nor is there any warranty concerning the ability of the ventilator to remove smoke, grease, or heat. There is no warranty that the ventilator will be approved by, or meet, any local codes. This is a material warranty only. If the equipment has been altered or repaired in any way, the Company shall have the right, in its sole discretion, to void the warranty. If the equipment has been improperly installed, subjected to misuse, been subjected to negligence, been subjected to accident, or been improperly maintained or lubricated, the Company shall have the right, in its sole discretion, to void the warranty.

Notice:

Replacement of silicone sealant is not covered by any warranty, express or implied, that is issued by Larkin Industries.

Motor Warranty

Electric motors carry a three year limited warranty. Larkin makes no warranty as to the MERCHANTABILITY or that the goods will be fit for any particular purpose. Larkin Industries, Inc. shall not be responsible for any incidental or consequential damages, the purchaser's sole and exclusive remedy being the repair or replacement set forth above. Larkin Industries, Inc. shall have no responsibility for loss of use of the equipment, loss of time, down time, inconvenience, commercial loss, consumer loss, loss of profits, or any other injuries or damages beyond the repair or replacement as set forth herein above. Larkin Industries, Inc. is not responsible to purchaser, or anyone else for any negligence, breach of contract, or damages, except as specifically set forth herein.

This warranty is expressly in lieu of all other warranties, whether expressed or implied, and in lieu of any and all obligations or liabilities on the part of the Company. The Company neither assumes, nor authorizes anyone to assume for it, any liability which is not set forth in the manufacturer's warranty. In the event Larkin Industries, Inc. receives a verbal order, there shall be no warranty that the goods will be shipped as ordered. All such orders are shipped at the risk of the buyer.



Commercial Kitchen Hood

Trouble Shooting

The following is a list of common causes and corrective actions for possible problems with exhaust hood systems. Please refer to this list prior to consulting manufacturer.

TROUBLE SHOOTING CHART

PROBLEM	POTENTIAL CAUSE	CORRECTIVE ACTION
No Exhaust air flow	Exhaust fan not operating	Check circuit breaker
		Check fan disconnect
		Check fan belt
		Check fan controls
	Incorrect Exhaust fan rotation	Change any two wiring leads to 3 Phase motor
		Check rotation arrow in fan
	Incorrect Exhaust fan on hood	Ensure correct fan is on hood and wired to correct fan controls
No Make-up air flow	Make-up air fan not operating	Check circuit breaker
		Check fan disconnect
		Check fan belt
		Check fan controls
	Incorrect Make-up air fan rotation	Change any two wiring leads to 3 Phase motor
		Check rotation arrow in fan
	Damper closed	Ensure damper is open
	Static pressure in duct system higher than design	Do not use flexible duct. Insure duct is as direct as possible from fan to hood
Hood not capturing smoke	Filters in fan clogged	Clean filters and replace
	Fire system not armed or has been activated	Ensure micro switch on fire system is wired properly. Arm fire system
	Dirty grease filters	Clean filters and replace
	Negative pressure in kitchen space	Increase make-up air (RPM / HP)
	Insufficient exhaust air flow	Increase exhaust fan (RPM / HP)
	Static pressure in duct system higher than design	Increase exhaust fan (RPM / HP). Increase duct size. Ensure duct is as direct as possible from fan to hood.
	Incorrect Exhaust fan rotation	Change any two wiring leads to 3 Phase motor
	Check rotation arrow in fan	
Fan cycles on and off	Motor over-amping	Check FLA of motor and adjust
		Check for correct wire size to motor
Light globes contain water	Curb and/or duct leaking	Check curb and/or duct for leaks and seal
Grease dripping from hood	Hood not cleaned	Adjust cleaning schedule
	Exhaust air flow too low	Increase exhaust fan (RPM / HP)
Grease dripping past grease tray	Grease tray installed upside down	Install grease tray with small portion of key hole in the up position