

# EZ Serve™ Condiment Cart

## Stainless Steel With VolPak® System

Spec. # \_\_\_\_\_



**Model #702-00**  
with 8 each  
dispensing pumps

### All of the convenience of VolPak condiment dispensing without the hassle of CO<sub>2</sub> tanks and pumps.

- Utilizes convenient, economical disposable 3-gallon condiment pouches.
  - Reduces labor to refill and clean pumps and containers by as much as 75%.
  - Eliminates theft and waste up to 30%.
  - Decreases food costs up to 30%.
- No refrigeration, electrical power or CO<sub>2</sub> tanks needed - operates with easy to use hand pumps
- Safe and sanitary method of dispensing.
  - Sealed, sanitary pouches are vacuum sealed.
  - Reduced risk of bacterial contamination and customer intervention.
  - Pouches are easier and safer to handle than cans.
- Durable, easy to use dispensers are within reach for teens and adults. Dispensers can be mounted in any direction.
- System handles various thicknesses of condiments, including available salsas and relishes.
- Locking doors provide easy access to the interior for changing product pouches. Doors are located on the serving side for quick access when it is placed against a wall.
- Cart is sized for maneuvering into elevators, down corridors and into serving areas.
- Stainless steel interior and exterior is easy to clean and sanitize. Wipe down or steam clean inside and out. All stainless steel exterior is standard.
- Easy to maneuver with four tough-duty 5" (127 mm) swivel casters, two with brake.



Snap-on connectors make changing bags easy. One connector fits all condiment brands.



Lift-out bins simplify changing condiment pouches and cleaning.



Convenient hand key screw clamps make hose removal and cleaning easy.



Optional stainless steel overshelf



Optional etched or color coded pump knobs easily identify condiments.

AIA # \_\_\_\_\_

**LAKESIDE**  
Ingenuity On Wheels™

Lakeside Manufacturing, Inc.

4900 West Electric Avenue • West Milwaukee, WI 53219 U.S.A.

800-558-8565 • 414-902-6400 • Fax 414-902-6446 • www.eLakeside.com

# EZ Serve™ Condiment Cart

## Stainless Steel With VolPak® System

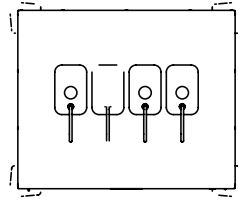
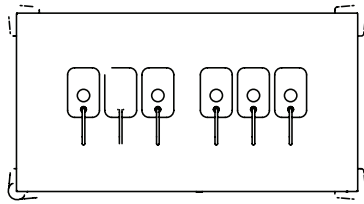

AutoCAD drawings available on KCL CADalog

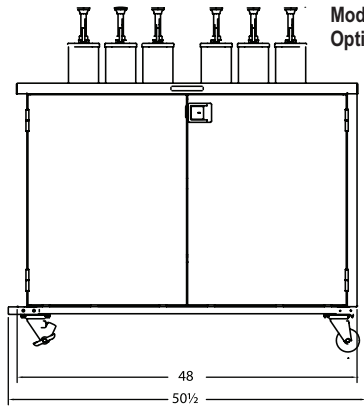

Model #702  
Option 10

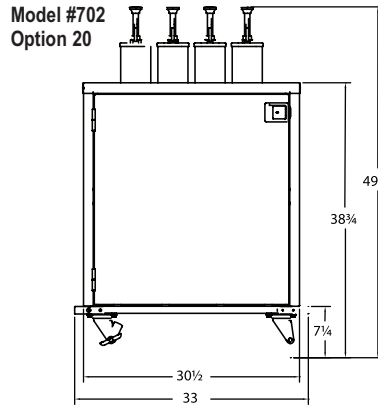

Model #702  
Option 20

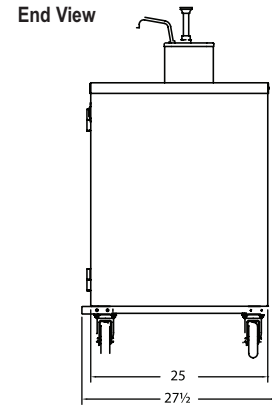

End View

### Dimensions:

Model	Option	Description	Overall Size			Ship Weight				
			W	L	H	(W)	(L)	(H)	Lbs.	(Kg)
702	00	8 Manual Pumps - up to 4 products	27 1/2"	50 1/4"	49 1/2"	(699)	(1276)	(1257)	460	(209)
	10	6 Manual Pumps - up to 3 products	27 1/2"	50 1/4"	49 1/2"	(699)	(1276)	(1257)	460	(209)
	20	4 Manual Pumps - up to 2 products	27 1/2"	33"	49 1/2"	(699)	(838)	(1257)	375	(169)
	70	12 Manual Pumps - up to 4 products	27 1/2"	50 1/4"	49 1/2"	(699)	(1276)	(1257)	472	(214)

Measurements in ( ) denote metric millimeters, unless otherwise noted.

### Pump Configuration Options (Custom configurations also available.)

#### Easy Ordering Instructions

- Specify model # and configuration. Eg: 70210
- Specify "SP" for custom dispenser configuration or optional exterior finishes. Eg: 70200SP

Call factory for assistance.

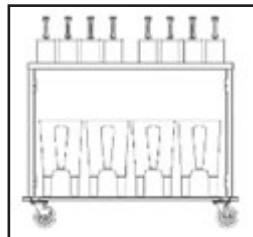

00 8 dispensing pumps (dispenses up to 4 condiment products)

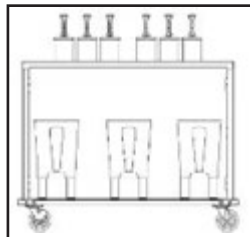

10 6 dispensing pumps (dispenses up to 3 condiment products)

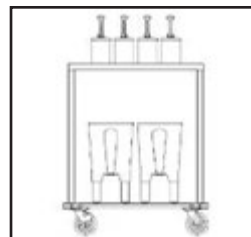

20 4 dispensing pumps (dispenses up to 2 condiment products)

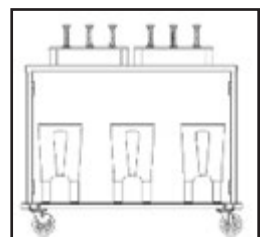

70 12 dispensing pumps (dispenses up to 4 condiment products)

### Specifications:

Cart shall feature a closed, sealed, sanitary dispensing system for utilizing economical 3-gallon bulk packed condiment product, and shall not require refrigeration or electrical power. Dispensing system shall include 4, 6 or 8 free flow manual dispenser pumps with flexible plastic supply hoses, and shall include 2, 3 or 4 polyethylene bins for storage of condiment product pouches. Supply hoses shall feature universal VolPak snap-on connectors to fit all brands of condiment products, and shall connect to pumps with convenient hand key screw clamps. Pumps shall be able to be cleaned in place or to be easily disassembled for cleaning. Hinged doors shall be locking. Standard interior and exterior finish shall be stainless steel for easy cleaning and sanitation. Cart shall have 4 each, 5" (127 mm) swivel Lake-Glide® casters, 2 ea. with brake.

### Optional Accessories:

- Stainless steel overshelf 12" x 39 3/4" x 4" (305mm x 1010mm x 102mm)
- Color coded and/or etched knobs for pumps.
- Group 2 or custom laminate finishes over stainless steel exterior.



Lakeside Manufacturing, Inc.

4900 West Electric Avenue • West Milwaukee, WI 53219 U.S.A.

800-558-8565 • 414-902-6400 • Fax 414-902-6446 • www.eLakeside.com