

Stainless Steel Utility Carts

Tough Transport® - 1000 Lb Capacity

Rugged “U” Frame With Angled Stainless Steel For Added Strength.

- Shelves are 14 gauge stainless steel with reinforced edges.
- All joints are continuous heliarc welded.
- Stainless steel construction resists staining and rusting.
- Steam clean or wipe down. Sanitizes easily.
- 1000 lb. (450 kg) capacity is ideal for continuous hauling of heavy loads over uneven floors and outdoor surfaces.



Model 954



Specifications

Unit shall be of fully welded stainless steel construction. Legs and frame shall be of U-frame design, eliminating the need for corner reinforcements. Shelves shall be of 14-gauge stainless steel, and shall be continuously TIG welded to vertical leg frames. Shelves shall be reinforced front and back with 18-gauge angle welded to the shelf underside. Unit shall have two each 5" (127 mm) diameter extra-load swivel casters with 1-1/4" (32 mm) wide non-marking polyurethane wheels, and 2 each 8" diameter extra-load wheels mounted to a fixed axle. Swivel casters shall be plate type and shall be bolted to an 18-gauge 5" wide stainless steel cross member with a galvanized reinforcement. Unit shall have push handle made of 18 gauge 1" O.D stainless steel tubing. Handle mounting brackets shall be continuously TIG welded to vertical leg frame. Unit shall have two each bumpers mounted to handle ends and two each 6" (152 mm) bumpers riveted to front legs. Unit shall be NSF listed.

Optional Accessories

- Extended perimeter bumper
- All 5" swivel casters
- Set of 2 each 5" (127 mm) brake casters
- Ground and polished joint welds



Lakeside Manufacturing, Inc.

4900 West Electric Avenue • West Milwaukee, WI 53219 U.S.A.
800-558-8565 • 414-902-6400 • Fax 414-902-6446 • www.eLakeside.com

Stainless Steel Utility Carts

Tough Transport® - 1000 Lb Capacity

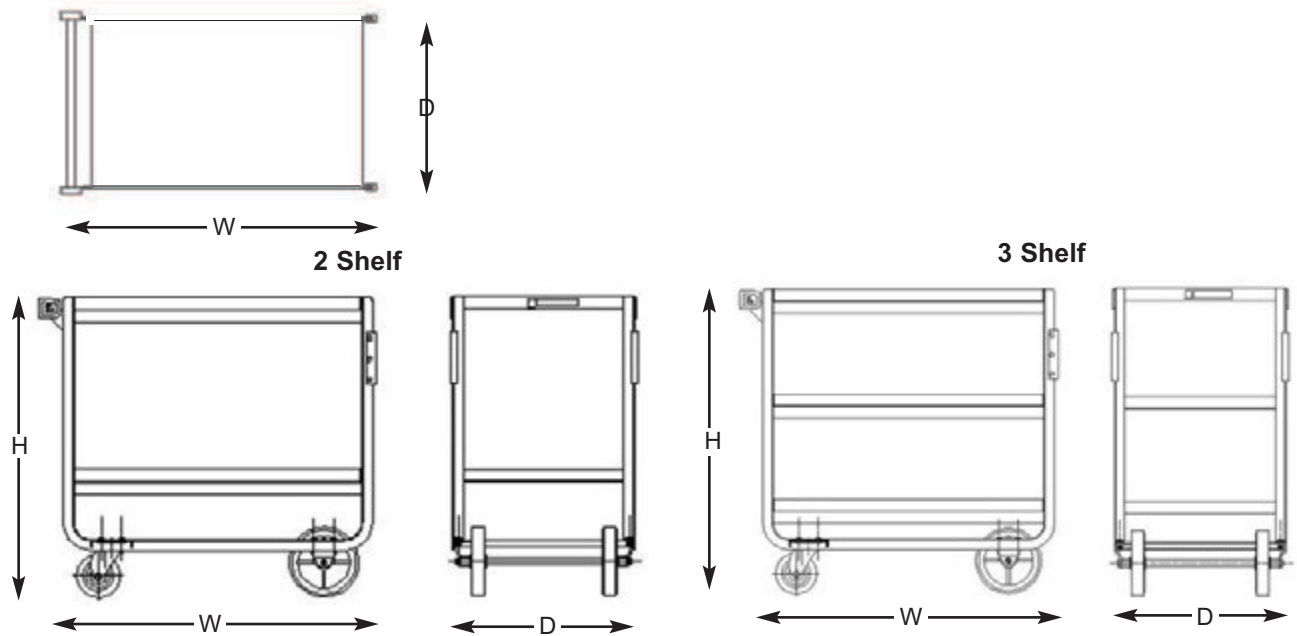

AutoCAD drawings available through KCL CADalog

Dimensions

Model	# of	Shelf Description		Overall Size			Case Weight	
		Shelves	Clearance	W	D	H	Lbs.	(Kg)
938	2	18" x 27" (457 x 686)	19" (483)	33" (838)	19-3/4" (502)	34-1/4" (870)	66	(29.9)
939	3	18" x 27" (457 x 686)	10" (254)	33" (838)	19-3/4" (502)	34-1/4" (870)	80	(36.3)
943	2	21" x 33" (533 x 838)	21" (533)	39" (991)	22-3/4" (578)	37-3/8" (949)	88	(39.9)
944	3	21" x 33" (533 x 838)	11-3/8" (289)	39" (991)	22-3/4" (578)	37-3/8" (949)	106	(48.1)
947	2	24" x 36" (610 x 914)	21" (533)	42" (1067)	25-7/8" (657)	37-3/8" (949)	106	(48.1)
949	3	24" x 36" (610 x 914)	11-3/8" (289)	42" (1067)	25-7/8" (657)	37-3/8" (949)	130	(59)
953	2	24" x 42" (610 x 914)	21" (533)	48" (1219)	25-3/4" (654)	37-3/8" (949)	126	(57.1)
954	3	24" x 42" (610 x 1067)	11-3/8" (289)	48" (1219)	25-3/4" (654)	37-3/8" (949)	152	(69)
958	2	21" x 49" (533 x 1245)	21" (533)	55" (1397)	22-3/4" (578)	37" (940)	123	(55.8)
959	3	21" x 49" (533 x 1245)	11-3/8" (289)	55" (1397)	22-3/4" (578)	37" (940)	150	(68)

Measurements in () denote metric millimeters, unless otherwise specified.

LAKESIDE[®]
Ingenuity On Wheels™

Lakeside Manufacturing, Inc.
4900 West Electric Avenue • West Milwaukee, WI 53219 U.S.A.
800-558-8565 • 414-902-6400 • Fax 414-902-6446 • www.eLakeside.com