

Portable Beverage Bar

Stainless Steel With Laminate Finish

Spec. #

AIA #



Model 886

Attractive Exterior For A Classic Presentation

Construction

- All-welded stainless steel with choice of laminate exterior

Features

- Built-in 40 lb. ice bins with drains
- Removable stainless steel speed rails
- Durable waterproof laminate top with convenient mixing shelf
- Spacious storage areas
- Stainless steel construction provides years of service life.

Casters

- All-swivel 5" non-marking, 2 each with brake

Specifications

Unit shall be Lakeside Model 886 and shall be constructed of welded stainless steel for easy cleaning and sanitation. The exterior shall be durable laminate over stainless steel. The top shall be constructed of 1-1/4" (32 mm) thick, waterproof laminate with black finish. The top shall feature a recessed stainless steel mixing shelf. Stainless steel interior shall have a generous work shelf with two each, 40 lb. (18 kg.) capacity ice bins with drains. Interior shall have stainless steel compartments for storage of beverages and supplies. Unit shall have two removable, 7-bottle speed rails constructed of stainless steel. Unit shall have 4 each non-marking 5" (127 mm) Lake-Glide® casters - all swivel, 2 each with brake.



Lakeside Manufacturing, Inc.

4900 West Electric Avenue • West Milwaukee, WI 53219 U.S.A.
800 558 8565 • 414 902 6400 • Fax 414 902 6446 • www.eLakesideFoodservice.com

Portable Beverage Bar

Stainless Steel With Laminate Finish

AIA #

Spec. #

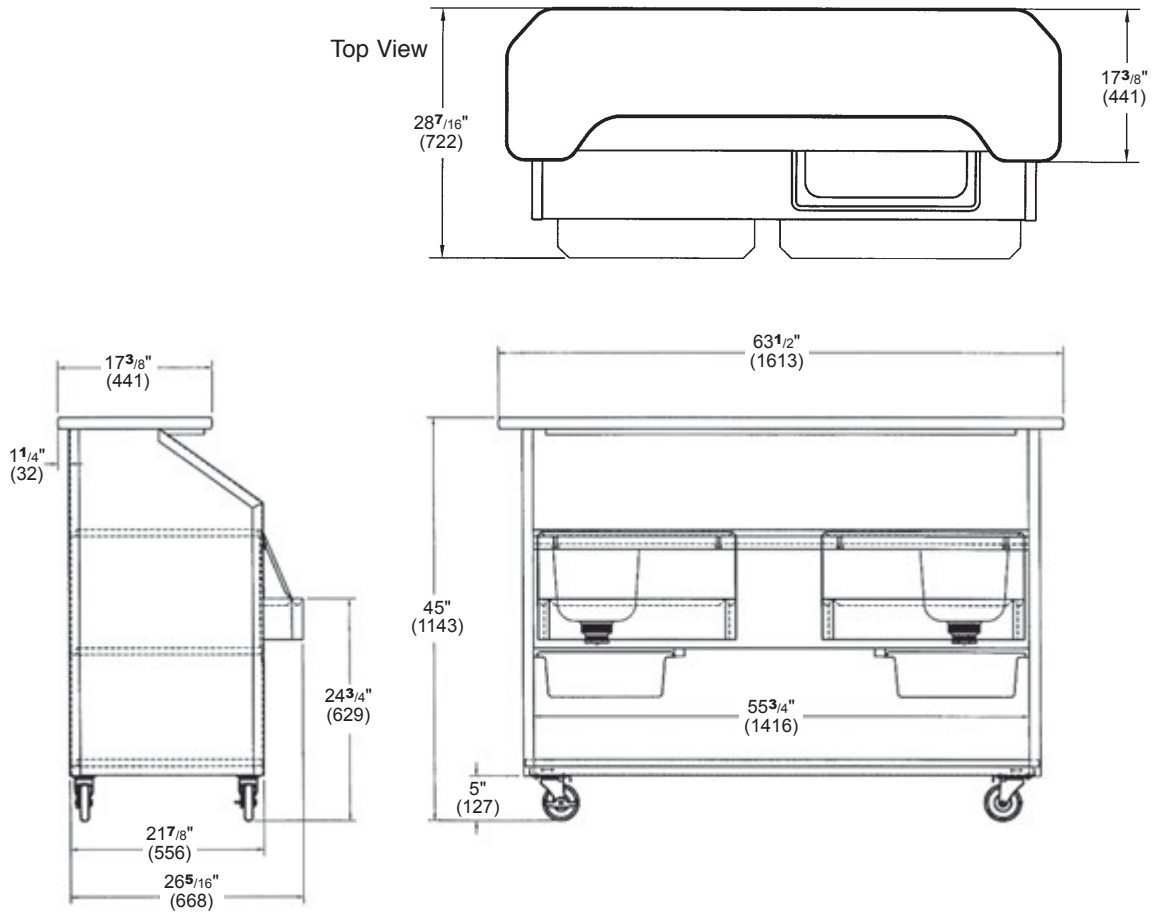

AutoCAD drawings available through KCL CADalog

Dimensions

Overall Dimensions: 27 3/4" W x 63 1/2" L x 45" H (705mm W x 1613mm L x 1143mm H)
 Total Ice Capacity: 80 lb. (36 kg.)
 Case Weight: 362 lb. (163 kg.)
 Unit Weight: 225 lb. (101 kg.)

Optional Accessories

- Custom laminate exterior finish:

Standard Exterior Finishes



Beige Suede



Red Maple



Black



Victorian Cherry



Gray Sand



Hard Rock Maple



Lakeside Manufacturing, Inc.

4900 West Electric Avenue • West Milwaukee, WI 53219 U.S.A.

800-558-8565 • 414-902-6400 • Fax 414-902-6446 • www.eLakesideFoodservice.com