

# Portable Beverage Bar

## Stainless Steel With Laminate Finish

Spec. # \_\_\_\_\_



Model 887



### Attractive Exterior For A Classic Presentation

#### Construction

- All-welded stainless steel with choice of laminate exterior

#### Features

- Built-in 40 lb. ice bin with drain
- Removable stainless steel speed rails
- Durable waterproof laminate top with convenient mixing shelf
- Spacious storage areas
- Stainless steel construction provides years of service life.

#### Casters

- All-swivel 5" non-marking, 2 each with brake

AIA # \_\_\_\_\_

### Specifications

Unit shall be Lakeside Model 887 and shall be constructed of welded stainless steel for easy cleaning and sanitation. The exterior shall be durable laminate over stainless steel. The top shall be constructed of 1-1/4" (32 mm) thick, waterproof laminate with black finish. The top shall feature a recessed stainless steel mixing shelf. Stainless steel interior shall have a generous work shelf with one 40 lb. (18 kg.) capacity ice bin with drain. Interior shall have stainless steel compartments for storage of beverages and supplies. Unit shall have two removable, 7-bottle speed rails constructed of stainless steel. Unit shall have 4 each non-marking 5" (127 mm) Lake-Glide® casters - all swivel, 2 each with brake.



Lakeside Manufacturing, Inc.

4900 West Electric Avenue • West Milwaukee, WI 53219 U.S.A.  
 800 558 8565 • 414 902 6400 • Fax 414 902 6446 • www.eLakesideFoodservice.com

# Portable Beverage Bar

Stainless Steel With Laminate Finish

AIA #

Spec. #

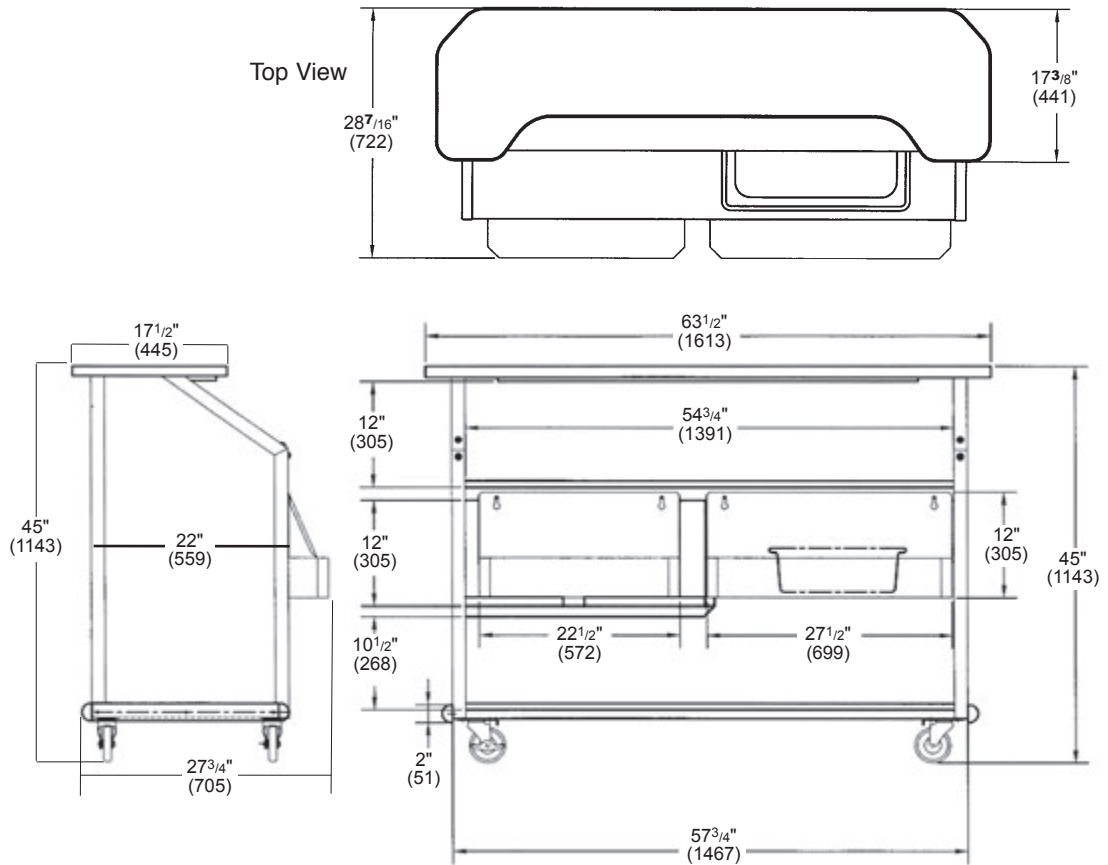

AutoCAD drawings available through KCL CADalog

## Dimensions

Overall Dimensions: 27 3/4" W x 63 1/2" L x 45" H (705mm W x 1613mm L x 1143mm H)  
 Total Ice Capacity: 40 lb. (18 kg.)  
 Case Weight: 351 lb. (158 kg.)  
 Unit Weight: 217 lb. (98 kg.)

## Optional Accessories

- Custom laminate exterior finish: \_\_\_\_\_

## Standard Exterior Finishes

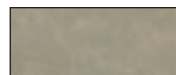

Beige Suede



Red Maple



Black



Victorian Cherry



Gray Sand



Hard Rock Maple



Lakeside Manufacturing, Inc.

4900 West Electric Avenue • West Milwaukee, WI 53219 U.S.A.

800-558-8565 • 414-902-6400 • Fax 414-902-6446 • www.eLakesideFoodservice.com