

# Mobile Self-Leveling Cabinets

## Non-Heated Stainless Steel



Model 5209

### Easy field adjustment for plate dispensing height - no tools required

#### Benefits

- Models available to fit plates from 5" (127 mm) to 12 1/4" (311 mm)
- Easy-Glide™ design provides quiet, non-stick operation

#### Construction

- All-welded stainless steel construction
- Corner bumpers protect cabinet, walls and doors

#### Casters

- 4" (102 mm) Lake-Glide® casters - all swivel, 2 with brake, extra-load



### Specifications

**Mobile Cabinet:** Mobile cabinets shall be of all-welded stainless steel construction. Cabinets shall have 18-gauge top and 20-gauge sides and bottom and shall include bottom corner bumpers. Cabinet base shall have center clean out hole. Casters shall be 4" (102 mm) diameter extra-load swivel (two with locking brake). Unit shall feature a heavy-duty independent undercarriage frame of galvanized steel to which casters shall be mounted. Units shall be NSF listed.

**Dispenser Tubes:** Dispenser tubes shall be of welded stainless steel construction and shall drop in to mobile cabinet top openings. Dispensers shall hang from cabinet opening by an 18-gauge flange ring and feature three each 22-gauge vertical side supports welded to 20-gauge bottom plate. Self-leveling dish carriage shall be of welded stainless steel construction and shall travel vertically in dispenser tube with nylon guides for smooth operation. Carriage shall have 22-gauge removable dish platform. Dispensers shall feature flange mounted perimeter extension springs, which are detachable from the dish carriage, to provide adjustment without tools for different weight dishes. Each dispenser shall have a vertical stacking capacity of 25" (635 mm).

Spec. # \_\_\_\_\_

AIA # \_\_\_\_\_



Lakeside Manufacturing, Inc.

4900 West Electric Avenue • West Milwaukee, WI 53219 U.S.A.  
800-558-8565 • 414-902-6400 • Fax 414-902-6446 • www.eLakesideFoodservice.com

# Mobile Self-Leveling Cabinets

## Non-Heated Stainless Steel

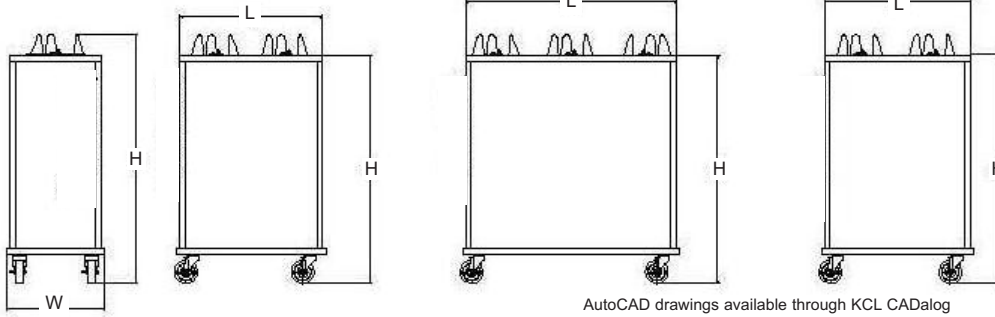

AutoCAD drawings available through KCL CADalog

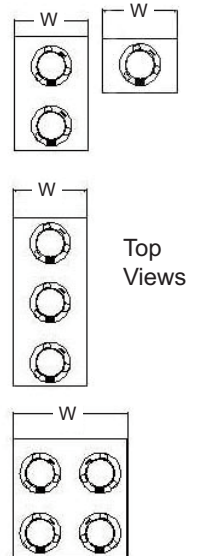

### Optional Accessories

- Stainless steel dispenser covers
- 8" (203 mm) vertical one-piece push handle (not available on four stack models)
- Bottom perimeter bumper

### Model Information

#### Single Stack Models

Model	Accommodates Plate Size	Dimensions			Ship Weight
		W	L	H	
5100	Up to 5" (Up to 127)	18½" (470)	22½" (571)	40" (1013)	74 (33.3 kg)
5105	5-1/8" to 5-3/4" (130 to 146)	18½" (470)	22½" (571)	40" (1013)	74 (33.3 kg)
5106	5-7/8" to 6-1/2" (149 to 165)	18½" (470)	22½" (571)	40" (1013)	76 (34.2 kg)
5107	6-5/8" to 7-1/4" (168 to 184)	18½" (470)	22½" (571)	40" (1013)	79 (35.6 kg)
5108	7-3/8" to 8-1/8" (187 to 206)	18½" (470)	22½" (571)	40" (1013)	85 (38.3 kg)
5109	8-1/4" to 9-1/8" (210 to 232)	18½" (470)	22½" (571)	40" (1013)	87 (39.2 kg)
5110	9-1/4" to 10-1/8" (235 to 257)	18½" (470)	22½" (571)	40" (1013)	89 (40.1 kg)
5111	10-1/4" to 11" (260 to 279)	18½" (470)	22½" (571)	40" (1013)	90 (40.8 kg)
5112	11-1/4" to 12-1/4" (286 to 311)	18½" (470)	22½" (571)	40" (1013)	93 (41.9 kg)

#### Two Stack Models

Model	Accommodates Plate Size	Dimensions			Ship Weight
		W	L	H	
5200	Up to 5" (Up to 127)	18½" (470)	32" (813)	40" (1013)	83 (37.7 kg)
5205	5-1/8" to 5-3/4" (130 to 146)	18½" (470)	32" (813)	40" (1013)	83 (37.7 kg)
5206	5-7/8" to 6-1/2" (149 to 165)	18½" (470)	32" (813)	40" (1013)	85 (38.6 kg)
5207	6-5/8" to 7-1/4" (168 to 184)	18½" (470)	32" (813)	40" (1013)	87 (39.5 kg)
5208	7-3/8" to 8-1/8" (187 to 206)	18½" (470)	32" (813)	40" (1013)	94 (42.6 kg)
5209	8-1/4" to 9-1/8" (210 to 232)	18½" (470)	32" (813)	40" (1013)	96 (43.6 kg)
5210	9-1/4" to 10-1/8" (235 to 257)	18½" (470)	32" (813)	40" (1013)	98 (44.5 kg)
5211	10-1/4" to 11" (260 to 279)	18½" (470)	32" (813)	40" (1013)	105 (47.6 kg)
5212	11-1/4" to 12-1/4" (286 to 311)	20¾" (527)	36½" (927)	40" (1013)	110 (49.8 kg)

#### Three Stack Models

Model	Accommodates Plate Size	Dimensions			Ship Weight
		W	L	H	
5300	Up to 5" (Up to 127)	18½" (470)	46½" (1178)	40" (1013)	149 (67.7 kg)
5305	5-1/8" to 5-3/4" (130 to 146)	18½" (470)	46½" (1178)	40" (1013)	149 (67.7 kg)
5306	5-7/8" to 6-1/2" (149 to 165)	18½" (470)	46½" (1178)	40" (1013)	152 (70.5 kg)
5307	6-5/8" to 7-1/4" (168 to 184)	18½" (470)	46½" (1178)	40" (1013)	155 (70.5 kg)
5308	7-3/8" to 8-1/8" (187 to 206)	18½" (470)	46½" (1178)	40" (1013)	163 (74.1 kg)
5309	8-1/4" to 9-1/8" (210 to 232)	18½" (470)	46½" (1178)	40" (1013)	164 (74.6 kg)
5310	9-1/4" to 10-1/8" (235 to 257)	18½" (470)	46½" (1178)	40" (1013)	165 (75.0 kg)

#### Four Stack Models

Model	Accommodates Plate Size	Dimensions			Ship Weight
		W	L	H	
5400	Up to 5" (Up to 127)	32" (813)	32" (813)	40" (1013)	176 (80.0 kg)
5405	5-1/8" to 5-3/4" (130 to 146)	32" (813)	32" (813)	40" (1013)	176 (80.0 kg)
5406	5-7/8" to 6-1/2" (149 to 165)	32" (813)	32" (813)	40" (1013)	177 (80.5 kg)
5407	6-5/8" to 7-1/4" (168 to 184)	32" (813)	32" (813)	40" (1013)	177 (80.5 kg)
5408	7-3/8" to 8-1/8" (187 to 206)	32" (813)	32" (813)	40" (1013)	178 (80.9 kg)
5409	8-1/4" to 9-1/8" (210 to 232)	32" (813)	32" (813)	40" (1013)	183 (83.2 kg)
5410	9-1/4" to 10-1/8" (235 to 257)	32" (813)	32" (813)	40" (1013)	184 (83.6 kg)

Measurements in ( ) denote metric millimeters, unless otherwise specified.



Lakeside Manufacturing, Inc.

4900 West Electric Avenue • West Milwaukee, WI 53219 U.S.A.

800-558-8565 • 414-902-6400 • Fax 414-902-6446 • www.eLakesideFoodservice.com

# Mobile Self-Leveling Cabinets

## Heated - Stainless Steel



Model 6209



### Easy Field Adjustment For Plate Dispensing Height Without Tools

#### Benefits

- Reduce breakage
- Easy to clean and sanitize
- Rolls to where dispensing is needed

#### Features

- All welded stainless steel construction
- Dispensers are field adjustable for dispensing level without tools
- Separate thermostatic heat controls for each dispenser

#### Casters

- Heavy-duty 4" plate-mount, 2 each with brake

### Specifications

**Mobile Cabinet:** Mobile cabinets shall be of all-welded stainless steel construction. Cabinets shall have 18-gauge top and 20-gauge sides and bottom and shall include bottom corner bumpers. Cabinet bottom shall have center clean out hole. Casters shall be 4" (102 mm) diameter extra-load swivel (two with locking brake). Unit shall feature a heavy-duty independent undercarriage frame of galvanized steel to which casters shall be mounted. Units shall be NSF listed.

**Dispenser Tubes:** Dispenser tubes shall be of welded stainless steel construction and shall drop into mobile cabinet top openings. Dispensers shall hang from cabinet opening by an 18-gauge flange ring, and feature three each 22-gauge vertical side supports welded to 20-gauge bottom plate. Self-leveling dish carriage shall be of welded stainless steel construction and shall travel vertically in dispenser tube with nylon guides for smooth operation. Carriage shall have 22-gauge removable dish platform. Dispensers shall feature flange mounted perimeter extension springs, which are detachable from the dish carriage, to provide adjustment without tools for different weight dishes. Each dispenser shall have a vertical stacking capacity of 25" (635 mm).

**Heating Unit:** Unit shall be 120 VAC 60 Hz and shall have 6' (1829 mm) coiled power supply cord with 5-15P NEMA plug (5-20P on Models 6409 and 6410) for 120 VAC. Cabinet shall have interior mounted electrical junction box with twist-lock receptacles for individual power to each dispenser. Dispenser tubes shall be fully enclosed in 22-gauge stainless steel, and have a circular bottom mounted 300 or 450 watt heater element. Heating system shall feature thermostatic control in a tamper protective location with safe high-end shut off. Control shall have infinite settings between low and high temperature cut-outs. Thermostat shall be field adjustable for average interior air temperature between 100° F (38° C) and 175° F (79° C) at middle adjustable thermostatic setting. On-off switch and power indicator light shall be mounted on top flange of dispenser. Average dish temperature rise of 40° F (22° C) above ambient shall be achieved within one hour of initial heating cycle at middle adjustable thermostatic setting. Cabinet and dispenser tubes shall be UL listed.



Lakeside Manufacturing, Inc.

4900 West Electric Avenue • West Milwaukee, WI 53219 U.S.A.  
800-558-8565 • 414-902-6400 • Fax 414-902-6446 • www.eLakesideFoodservice.com

# Mobile Self-Leveling Cabinets

## Heated - Stainless Steel

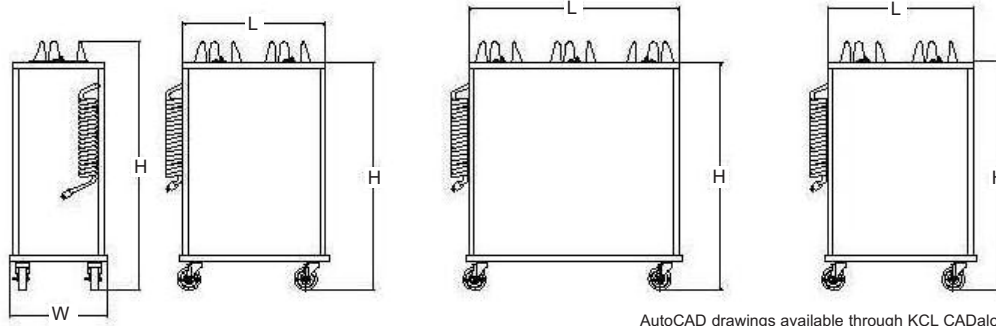

AutoCAD drawings available through KCL CADalog

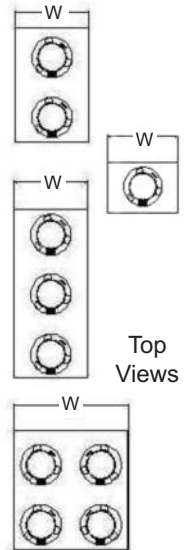

### Model Information

#### Single Stack Models

Model	Accommodates Plate Size	Dimensions			Electrical		Ship Weight
		W	L	H	Watts	Amps	
6100	Up to 5" (127)	18½"	22½"	40"	300	2.5	93 (42.1 kg)
6105	5-1/8" to 5-3/4" (130 to 146)	18½"	22½"	40"	300	2.5	93 (42.1 kg)
6106	5-7/8" to 6-1/2" (149 to 165)	18½"	22½"	40"	300	2.5	95 (42.8 kg)
6107	6-5/8" to 7-1/4" (168 to 184)	18½"	22½"	40"	300	2.5	98 (44.1 kg)
6108	7-3/8" to 8-1/8" (187 to 206)	18½"	22½"	40"	300	2.5	105 (47.3 kg)
6109	8-1/4" to 9-1/8" (210 to 232)	18½"	22½"	40"	450	3.75	110 (49.5 kg)
6110	9-1/4" to 10-1/8" (235 to 257)	18½"	22½"	40"	450	3.75	115 (51.8 kg)
6111	10-1/4" to 11" (235 to 279)	18½"	22½"	40"	450	3.75	122 (51.8 kg)
6112	10-1/4" to 12-1/4" (260 to 311)	18½"	22½"	40"	450	3.75	122 (55.0 kg)

#### Two Stack Models

Model	Accommodates Plate Size	Dimensions			Electrical		Ship Weight
		W	L	H	Watts	Amps	
6200	Up to 5" (127)	18½"	32"	40"	600	5.0	100 (45.2 kg)
6205	5-1/8" to 5-3/4" (130 to 146)	18½"	32"	40"	600	5.0	100 (45.2 kg)
6206	5-7/8" to 6-1/2" (149 to 165)	18½"	32"	40"	600	5.0	103 (46.7 kg)
6207	6-5/8" to 7-1/4" (168 to 184)	18½"	32"	40"	600	5.0	106 (48.1 kg)
6208	7-3/8" to 8-1/8" (187 to 206)	18½"	32"	40"	600	5.0	117 (53.1 kg)
6209	8-1/4" to 9-1/8" (210 to 232)	18½"	32"	40"	900	7.5	121 (54.9 kg)
6210	9-1/4" to 10-1/8" (235 to 257)	18½"	32"	40"	900	7.5	125 (56.9 kg)
6211	10-1/4" to 11" (235 to 279)	18½"	32"	40"	900	7.5	138 (62.6 kg)
6212	10-1/4" to 12-1/4" (260 to 311)	20¾"	36½"	40"	900	7.5	138 (62.6 kg)

#### Three Stack Models

Model	Accommodates Plate Size	Dimensions			Electrical		Ship Weight
		W	L	H	Watts	Amps	
6300	Up to 5" (127)	18½"	46½"	40"	900	7.5	171 (77.4 kg)
6305	5-1/8" to 5-3/4" (130 to 146)	18½"	46½"	40"	900	7.5	171 (77.4 kg)
6306	5-7/8" to 6-1/2" (149 to 165)	18½"	46½"	40"	900	7.5	176 (80.0 kg)
6307	6-5/8" to 7-1/4" (168 to 184)	18½"	46½"	40"	900	7.5	180 (81.8 kg)
6308	7-3/8" to 8-1/8" (187 to 206)	18½"	46½"	40"	900	7.5	192 (87.3 kg)
6309	8-1/4" to 9-1/8" (210 to 232)	18½"	46½"	40"	1350	11.3	169 (89.1 kg)
6310	9-1/4" to 10-1/8" (235 to 257)	18½"	46½"	40"	1350	11.3	200 (90.9 kg)

#### Four Stack Models

Model	Accommodates Plate Size	Dimensions			Electrical		Ship Weight
		W	L	H	Watts	Amps	
6400	Up to 5" (127)	32"	32"	40"	1200	10.0	188 (85.4 kg)
6405	5-1/8" to 5-3/4" (130 to 146)	32"	32"	40"	1200	10.0	188 (85.4 kg)
6406	5-7/8" to 6-1/2" (149 to 165)	32"	32"	40"	1200	10.0	192 (87.3 kg)
6407	6-5/8" to 7-1/4" (168 to 184)	32"	32"	40"	1200	10.0	193 (87.4 kg)
6408	7-3/8" to 8-1/8" (187 to 206)	32"	32"	40"	1200	10.1	220 (100.0 kg)
6409	8-1/4" to 9-1/8" (210 to 232)	32"	32"	40"	1800	15.0	222 (100.1 kg)
6410	9-1/4" to 10-1/8" (235 to 257)	32"	32"	40"	1800	15.0	225 (102.3 kg)

#### Options

- Perimeter bumper
- 208/240 VAC 60Hz
- 220 VAC 50Hz
- Stainless steel dispenser covers
- Push handle, vertical one-piece (2- and 3-stack models only)

Measurements in ( ) denote metric millimeters, unless otherwise specified.



Lakeside Manufacturing, Inc.

4900 West Electric Avenue • West Milwaukee, WI 53219 U.S.A.  
800-558-8565 • 414-902-6400 • Fax 414-902-6446 • www.eLakesideFoodservice.com