



Simply Engineered Better

# DF

Rotary Type Fully Automatic Glasswashing Machine



## SPECIFIER STATEMENT

Specified unit will be Moyer Diebel model DF Rotary Type, fully automatic glasswasher.

Unit will have detergent pump, sanitizer pump and rinse aid pump, standard upper and lower wash/rinse arms, wash tank heater, cold water final rinse, polypropylene conveyor, splash curtain, double-walled construction, storage space for three 1-gallon chemical containers.



Project \_\_\_\_\_

Item No. \_\_\_\_\_

Quantity \_\_\_\_\_

### STANDARD FEATURES

- **1,200 glasses per hour**
- 12" clearance accepts taller stemware
- Cool water rinse ensures steady supply of clean, cool glasses ready for immediate use, reducing labor and breakage
- Built-in three pump injection system uses iodine or chlorine sanitizer
- **Upper and lower** wash and rinse arms for superior wash results
- Polypropylene rotary conveyor eliminates chipping of stemware
- Built-in mixing valve for controlling rinse temperature
- Internal upper drain screen for improved filtration and ease of cleaning
- Self flushing wash chamber reduces maintenance
- Cabinet provides convenient storage for chemicals
- No steam generated behind the bar
- Include 6' NEMA 6-15p cord and plug
- Includes drain tray waste collector
- One year parts and labor warranty

MODEL DF GLASSWASHER

### OPTIONS & ACCESSORIES

- |  |             |
|--|-------------|
| <input type="checkbox"/> Quick disconnect package (incl. casters)    | P/N 0707258 |
| <input type="checkbox"/> Casters; set of four – 2 locking, 2 regular | P/N 0701962 |
| <input type="checkbox"/> Hand sink and wet waste receiver (SW46)     | P/N 0708453 |
| <input type="checkbox"/> Wash down hose                              | P/N 0701956 |
| <input type="checkbox"/> Site Glass kit                              | P/N 0712993 |
| <input type="checkbox"/> Drain Tray Waste Collector                  | P/N 0712734 |

MD005 Printed in U.S.A.

Moyer Diebel – USA

3765 Champion Blvd, Winston-Salem, NC 27105 Tel: 336/661-1992 Fax: 336/661-1979 800/228-8350 www.moyerdiebel.com





Simply Engineered Better

**DF**

Rotary Type Fully Automatic  
Glasswashing Machine

Dimensions shown in inches and [millimeters]

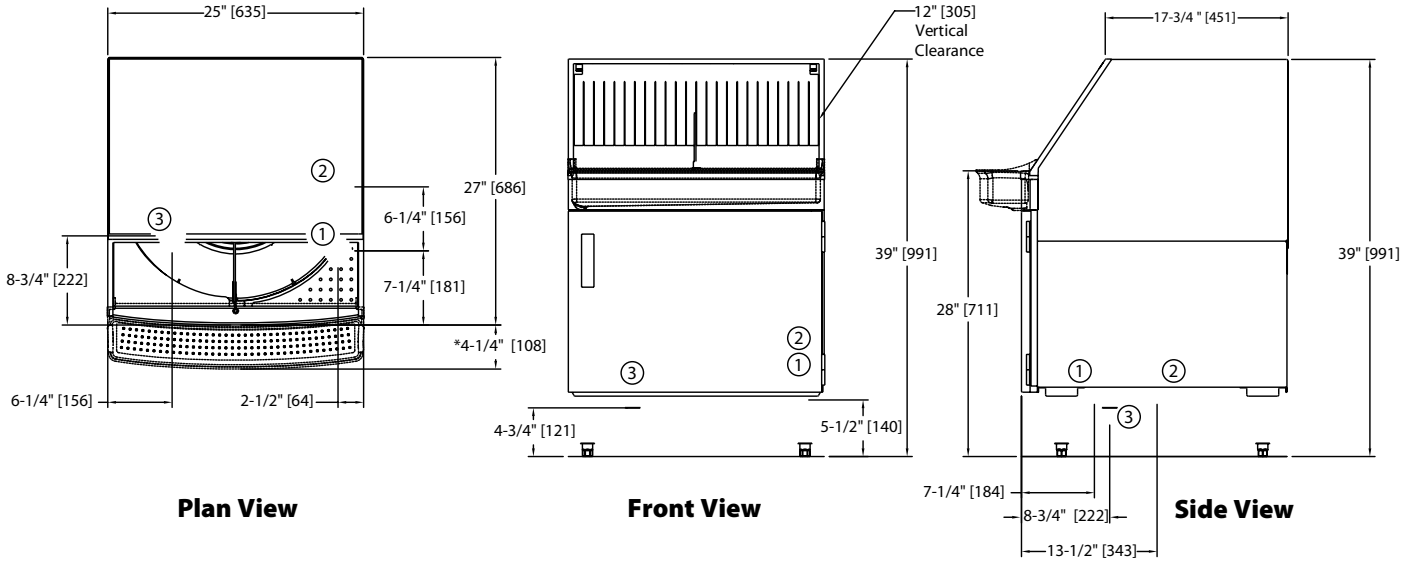

Utilities	
	<b>Electrical</b> 208 - 230/60/1, 15 amp (supplied with 6' plug-in cord NEMA 6-15p)
<b>1</b>	<b>Hot water connection</b> 1/2" [13] IPS. Flow pressure 25-95 psi [172.5-656 kPa]
<b>2</b>	<b>Cold water connection</b> 1/2" [13] IPS. Flow pressure 25-95 psi [172.5-656 kPa]
<b>3</b>	<b>Drain connection</b> 1-1/2" [38] tailpiece. Connect to drain size according to local plumbing code.

**NOTE:** DF Models supplied with 6 ft. [1829] plug in cord. (NEMA 6-15P)

**Warning:** Plumbing and electrical connections must be made by qualified personnel who will observe all the applicable plumbing, sanitary and safety codes.

	Uncrated	Crated
<b>Height</b>	39" [991]	46-1/2" [1181]
<b>Width</b>	25" [635]	27" [685]
<b>Depth</b>	27" [686]	27-1/2" [698]
<b>Ship Wt.</b> lbs/kg	156/71	176/80
* Adjustable foot height - 1-1/4" [45]		

**SPECIFICATIONS**

<b>Capacity (hr.)</b> 2-1/2" [64] glasses	1200
<b>Water Consumption</b> Cold water (approx.)	2.5 US gpm; 2.1 imp. gpm
Hot water (initial fill) (Max use – approx. 12 US gph)	3 US gallons;
<b>Temperatures °F/C</b> Inlet water (hot)	140-160
Inlet water (cold)	75
<b>Heating</b> Tank heat, electric (kW)	3
<b>Conveyor Movement</b>	Clockwise