

Item No. \_\_\_\_\_

Quantity \_\_\_\_\_

**Model No.**  
**6550-DW**  
**6550-SF**  
**Mini Cart**



6550-DW



6550-SF

Cash in on the fan-favorite hot dog with the fun and character of Nemco's mini cart merchandisers, designed to fit the space and décor of virtually any countertop or bar. The mini carts have fully adjustable heating controls that let you set and monitor temperatures with ease. Inserts and accessories provide exceptional flexibility and let you adapt well to changing menu items. Standard models steam and hold as many hot dogs as a New York City street cart. This countertop dog wagon presents a fun way to add some merchandising punch!

**Standard Features:**

- Heavy duty stainless steel construction
- Adjustable thermostat 120° F to 212° F
- Heating system design allows for fast preheat, and extended life of the unit
- Cycling indicator pilot light
- Temperature indicator setting: High, Medium, Low
- Accepts a 12" x 20" full size pan or fractional sizes
- Umbrella, pans & lids come with every unit
- Custom graphics are available
- UL and CUL certified

**Accessories:**

- 3 standard pan configurations available (or call for additional options)



NEMCO Food Equipment, Ltd.  
 301 Meuse Argonne  
 P.O. Box 305  
 Hicksville, OH 43526  
 Phone (419) 542-7751  
 FAX (419) 542-6690  
[www.nemcofoodequip.com](http://www.nemcofoodequip.com)



Dog Wagons based on the design of Nemco's proven 6055A.





# Mini Cart

## Model No. 6550-DW, 6550-SF

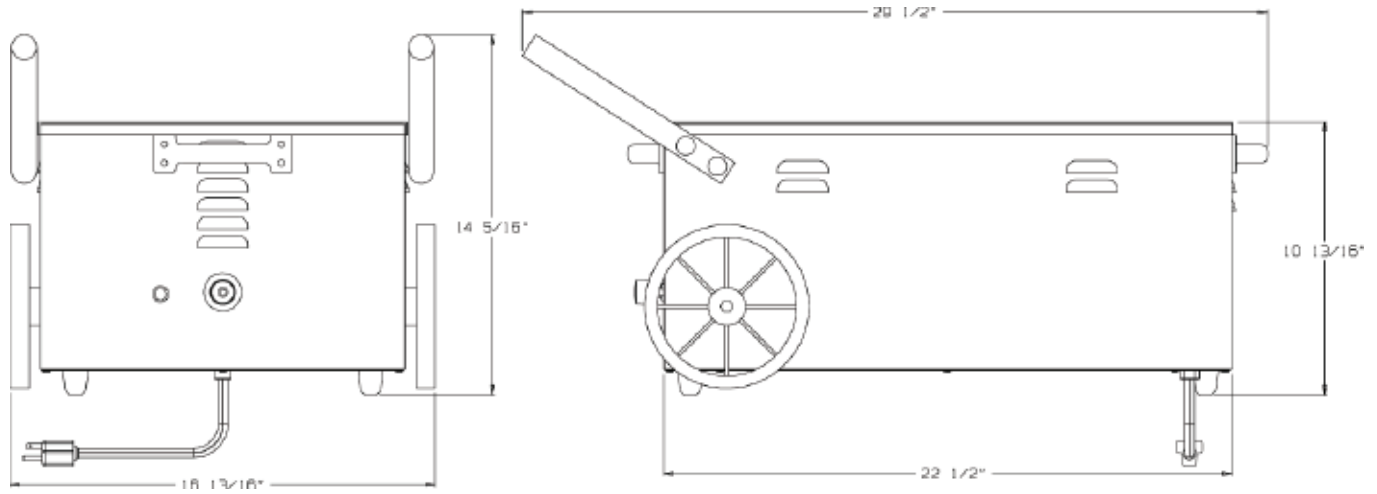

### SPECIFICATIONS:

Model No.	Pre-heat time to 180° F	Width Inches/(cm)	Depth Inches/(cm)	Height Inches/(cm)	Voltage	Rated Wattage	Nominal Amps	Plug Configuration	Unit Weight lbs. / (kg)	Shipping Weight lbs. / (kg)
6550-DW	10 min.	23 7/8 (60.6)	14 5/8 (37.1)	10 1/2 (26.7)	120	1200	10.0	NEMA 5-15P	23 (10.4)	27 (12.2)
6550-SF	10 min.	23 7/8 (60.6)	14 5/8 (37.1)	10 1/2 (26.7)	120	1200	10.0	NEMA 5-15P	23 (10.4)	27 (12.2)

\*\* Height with umbrella: 46 1/2 " (118.1)

Standard Pan Configuration: Please specify when ordering.

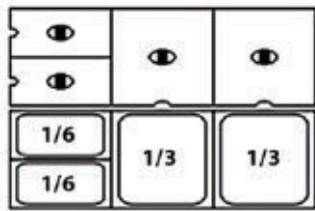

Pan configuration - option 1

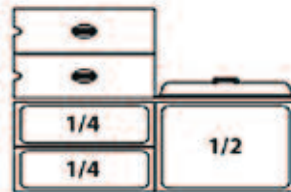

Pan configuration - option 2

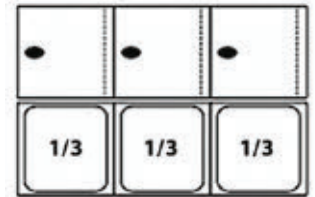

Pan configuration - option 3

Note: Additional pan configurations available - please call factory.

### TYPICAL SPECIFICATIONS

NEMCO mini cart shall be constructed with 300 series stainless steel wells and 400 series stainless steel exterior. They shall have tubular heating elements attached to an aluminum heat dissipator plate. All models shall have an adjustable (up to 212° F) conduction thermostat. 120 Volt models shall have a 6' cord and NEMA 5-15P plug. All 120 Volt models shall be United States and Canadian Underwriter's Laboratory certified.



NEMCO Food Equipment, Ltd.  
 301 Meuse Argonne  
 Hicksville, Ohio 43526  
 1.800.782.6761  
 419.542.7751  
 419.542.6690 Fax  
 www.nemcofoodequip.com