

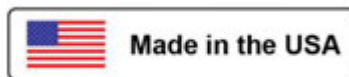

JOB:
ITEM:
QTY:



QUEEN MARY-ALUMINUM

APPLICATION:

These units are built for transporting big loads for banquets, catering, and bussing. The solid shelves have marine edges that add strength and contain spills.

MATERIAL:

Framework is constructed of 1 3/4"x 1 3/4"x.100" wall Queen Mary Tube (tube with 3/4" radius to the outside of unit). Shelves are constructed of .080" sheet aluminum reinforced with 1 1/4"x1 1/4"x.070" wall tubing. Base is constructed of 1 3/4"x1 3/4"x.070" wall tubing.

CASTERS:

These racks come equipped with four 8" platform type casters, two swivel and two rigid.

GUARANTEE:

These units carry a **Lifetime Guarantee** against rust and corrosion and also carry a **Five-Year Guarantee** against workmanship and material defects.



Model #1450



Phone:800-255-0104
Fax: 877-877-7687
www.newageindustrial.com
sales@newageindustrial.com

New Age Industrial reserves the right to modify or make changes at any time without notice to materials and specifications.

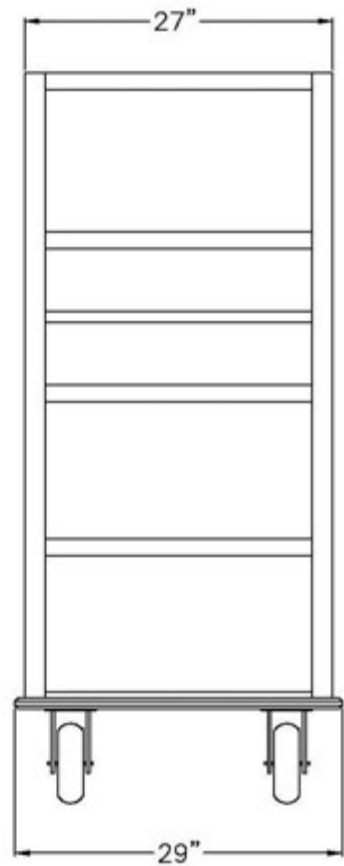
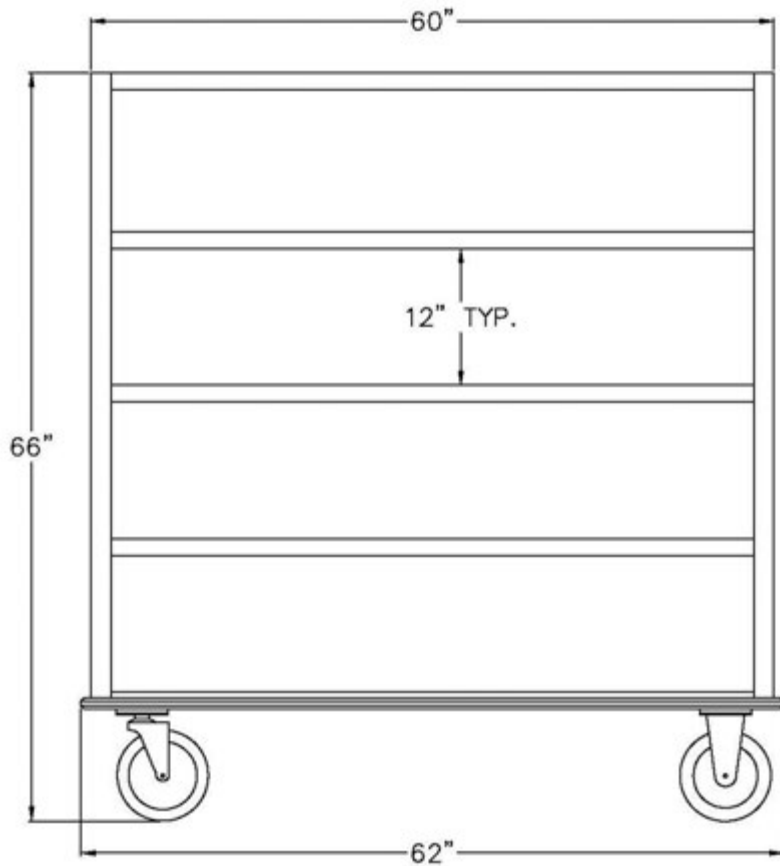

Model #1450

Model No.	Size-W	Size-H	Size-D	Wt. Cap.	No. Shelves	Shelf Spacing
1450	29"	66"	62"	3000#	5	12"
1451	29"	66"	75"	2500#	5	12"
1452	29"	66"	62"	2500#	4	16 1/2"
1455	29"	66"	62"	3000#	6	9 1/4"

*Each Unit is Equipped with a Full Perimeter Bumper



Phone: 800-255-0104
 Fax: 877-877-7687
www.newageindustrial.com
sales@newageindustrial.com

New Age Industrial reserves the right to modify or make changes at any time without notice to materials and specifications.