

Project: \_\_\_\_\_

Item: \_\_\_\_\_

Quantity: \_\_\_\_\_

## Queen Mary -Stainless



97942

These units are built for transporting big loads for banquets, catering, and bussing. The solid shelves have marine edges that add strength and contain spills.

- Framework is constructed of 1 $\frac{3}{4}$ " x 1 $\frac{3}{4}$ " x .100" wall Queen Mary Tube (tube with  $\frac{3}{4}$ " radius to the outside of unit).
- Removable shelves are constructed of 16-gauge stainless steel.
- Base is constructed of 1 $\frac{3}{4}$ " x 1 $\frac{3}{4}$ " x .070" wall tubing.
- Equipped with four 8" platform type casters, two swivel and two rigid.
- Five-Year Guarantee against material defects and workmanship.
- Lifetime Guarantee against rust and corrosion.

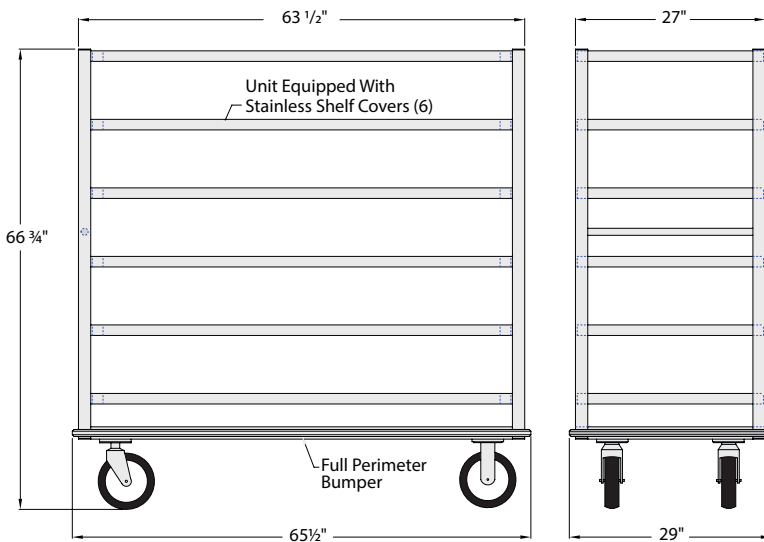

98183

### ► Queen Mary - Stainless

Model No.	Size D-H-L	Weight Capacity	# Of Shelves	Shelf Spacing	Ship Lbs.
97942	29" x 66 $\frac{3}{4}$ " x 65 $\frac{1}{2}$ "	3000 lbs.	5	10 $\frac{1}{2}$ "	355
98181	29" x 66 $\frac{3}{4}$ " x 78 $\frac{1}{2}$ "	2500 lbs.	5	10 $\frac{1}{2}$ "	351
98182	29" x 66 $\frac{3}{4}$ " x 65 $\frac{1}{2}$ "	2500 lbs.	4	14 $\frac{1}{2}$ "	322
98183	29" x 66 $\frac{3}{4}$ " x 65 $\frac{1}{2}$ "	3000 lbs.	6	8 $\frac{1}{4}$ "	365

Four 8" platform type casters—two swivel (#C526) two rigid (#C527).

**Each Unit Is Equipped With A Full Perimeter Bumper.**

#### Options:

- Caster Locks (2)** — Add "CL" suffix to model #.
- Towing Options Available** — Call For Pricing



**New Age Industrial Corp., Inc. || [NewAgeIndustrial.com](http://NewAgeIndustrial.com) || Made in the USA**

PO Box 520 • 16788 US Hwy 36 • Norton, Kansas 67654 || **Phone: (800) 255-0104 • (785) 877-5121** || Fax: (877)-877-7687 • (785) 877-2616

This information is for general sales and engineering use only. New Age Industrial reserves the right to modify or make changes at any time, without notice, to materials and specifications.