

Job: _____

Item: _____

Quantity: _____

#50112 Bulk Sheet Pan Dolly

- Ideal for hotel, casino, hospital and correctional facilities.
- This unit will store and transport up to 140 sheet pans.
 - Designed to hold sheet pans at a backward angle to keep the stack from tipping forward outside of the frame.
- Heavy duty caster mounting plates are welded to the rack for extra caster strength.
 - Four, 3/8" thick, pre-tapped caster plates are welded to base frame to accept 8" x 2" polyurethane tread swivel platform casters.
- Overall Construction:
 - Frame consists of 1 1/2" sq. tube with .070 wall thickness, top and bottom frame, 1 1/2" x 1 3/4" tube with .070 wall thickness uprights.
 - Pans rest on a set of 2" x 2" angles with .125 wall thickness.
- Can be customized to meet your specific needs.
- Lifetime Guarantee against rust and corrosion.

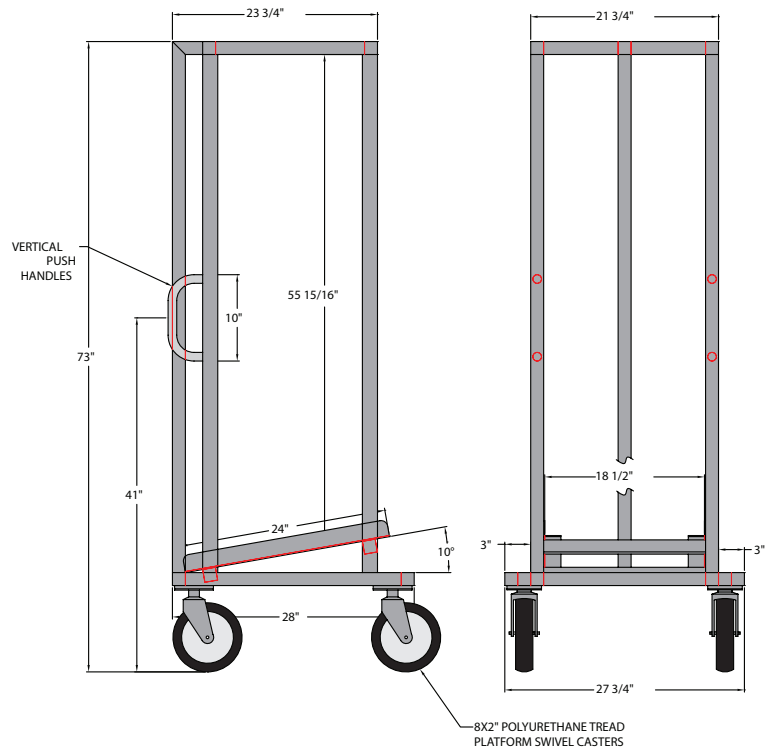

Model No.	Size W-H-D	Pan Cap.	Ship Wt.
50112	27 3/4" x 73" x 28 1/2"	140	68#

Equipped with four, 8" x 2" plate type swivel casters (#C526).

This information is for general sales and engineering use only. New Age Industrial reserves the right to modify or make changes at any time without notice to materials and specifications.

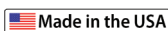

Distributed by: