

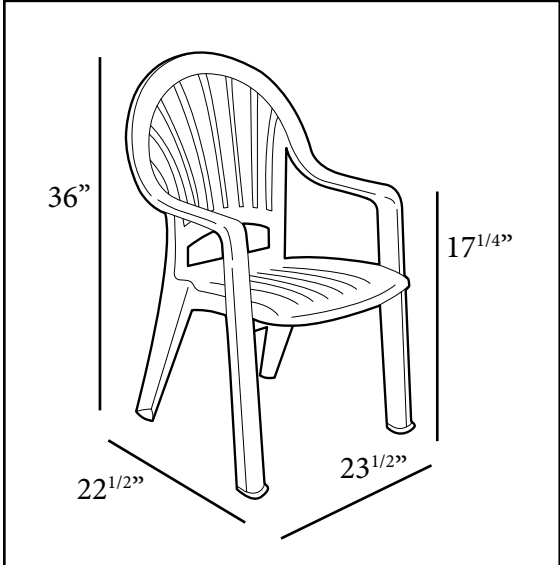

COMMERCIAL RESIN FURNITURE

Your best value for Food Service & Hospitality!

Pacific Fanback Stacking Armchair



Passes ASTM F 1561-96 Class B performance standard for commercial outdoor seating

Features & Benefits **Warranty: 5 Yrs.**

- A food service and hospitality industry standard.
- Solid one-piece molded construction.
- Constructed of 100% prime resin; a material impervious to salt air, chlorine and most common stains.
- Resists discoloration because of U.V. stabilizers.
- Attractive high gloss finish.
- Heavy duty contract grade armchair.
- Fanback design provides a distinctive look, plus support and comfort.
- Rated to 300 pounds for safe use in commercial environments.
- Stacks for easy storage.
- Withstands weather extremes.
- Stays cool to the touch in the hot sun.
- Cleans easily with soap and water.

Product Specifications

Product Description	Reference Number	Color	UPC Code	Weight Each (lbs.)	Master Pack	Master Pack Volume (cu. ft.)
Pacific Fanback Stacking Armchair	49092004	White	100470	11.06	16	40.67
	US092004	White	100470	12.25	4	16.02
	49092066	Sandstone	100500	11.06	16	40.67
	US092066	Sandstone	100500	12.25	4	16.02
	49092078	Amazon Green	100524	11.06	16	40.67
	US092078	Amazon Green	100524	12.25	4	16.02