

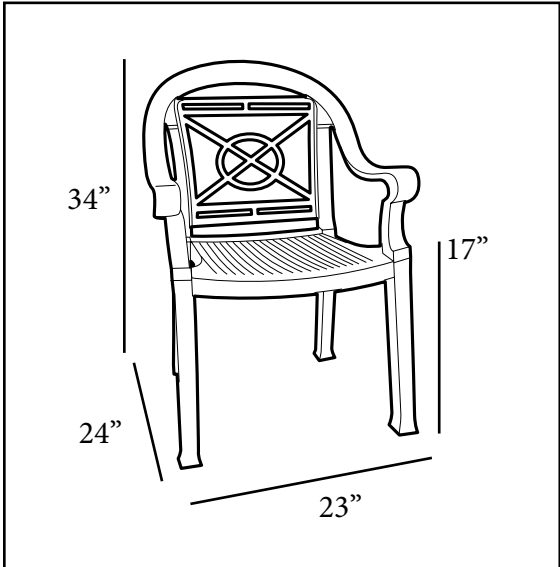

Victoria Classic Stacking Armchair



Passes ASTM F 1561-96 Class B performance standard for commercial outdoor seating

Features & Benefits **Warranty: 3 Yrs.**

- Elegant and comfortable highback armchair with a contoured back for indoor/outdoor dining areas.
- Made of Kevring® cast synthetic resin, a proprietary resin composite specifically developed to build functional yet durable commercial outdoor furniture with a true metal texture and design.
- Rated to 300 pounds for safe use in commercial environments.
- Will retain its original color, texture, and finish without rusting, even when exposed to the rigours of outdoor elements.
- 2" x 2" legs with hard wearing footpads for structural rigidity.
- Stacks for easy storage.

| Product Specifications | | | | | | |
|------------------------------------|------------------|-------------|-----------------|--------------------|-------------|------------------------------|
| Product Description | Reference Number | Color | UPC Code 014306 | Weight Each (lbs.) | Master Pack | Master Pack Volume (cu. ft.) |
| Victoria Classic Stacking Armchair | 46214002 | Charcoal | 120911 | 11.00 | 12 | 40.67 |
| | US214002 | Charcoal | 120911 | 11.00 | 4 | 20.90 |
| | 46214037 | Bronze Mist | 128191 | 11.00 | 12 | 40.67 |
| | US214037 | Bronze Mist | 128191 | 11.00 | 4 | 20.90 |
| | | | | | | |
| | | | | | | |
| | | | | | | |