

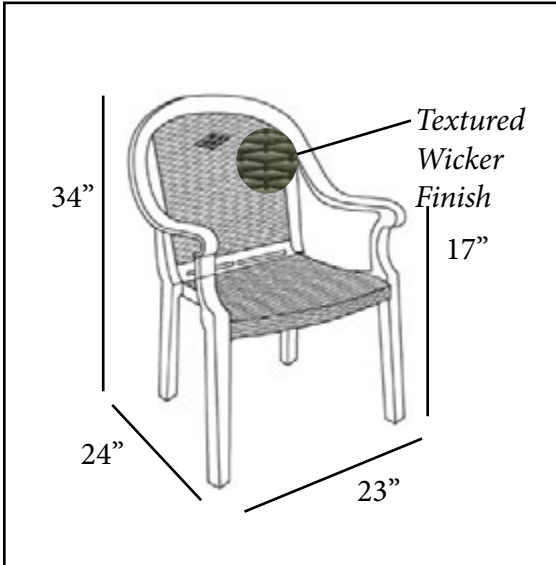

COMMERCIAL RESIN FURNITURE

Your best value for Food Service & Hospitality!

# Sumatra Classic Stacking Armchair



Passes ASTM F 1561-96 Class B performance standard for commercial outdoor seating

**Features & Benefits** **Warranty: 3 Yrs.**

- Trendy wicker backrest and seat texture and finish
- Comfortable highback armchair with firm back support.
- Easy to clean with soap and water - or a mild detergent.
- Will stay cool in the hot sun.
- 2" x 2" legs with hard wearing footpads for structural rigidity.
- Rated to 300 pounds for safe use in commercial environments.
- Will retain its original color, texture, and finish without rusting, even when exposed to the rigors of the outdoor elements.
- Stacks for easy storage.

<b>Product Specifications</b>						
Product Description	Reference Number	Color	UPC Code 014306	Weight Each (lbs.)	Master Pack	Master Pack Volume (cu. ft.)
Sumatra Classic Stacking Armchair	US720037	Bronze Mist	138961	11.00	16	54.06
	99720037	Bronze Mist	138961	10.52	4	20.70
	US720002	Charcoal	908441	11.00	16	54.06
	99720002	Charcoal	908441	10.52	4	20.70