

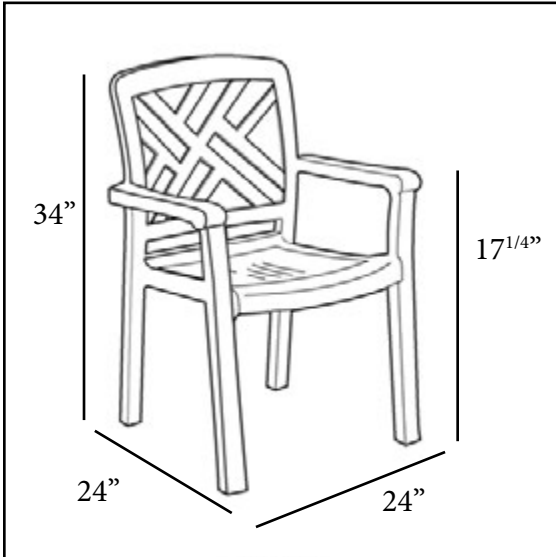

COMMERCIAL RESIN FURNITURE

Your best value for Food Service & Hospitality!

Sanibel Classic Stacking Armchair



Passes ASTM F 1561-96 Class B performance standard for commercial outdoor seating

Features & Benefits **Warranty: 3 Yrs.**

- Elegant and sturdy highback armchair for fine dining.
- Decorative chippendale back design.
- Spacious seat and wide armrests for extra comfort.
- Rated to 300 pounds for safe use in a commercial environment.
- Wood grained with a satin finish.
- 2" x 2" leg with hard wearing footpads for structural rigidity.
- Made of 100% prime resin, a material impervious to salt air, chlorine, and most common food stains.
- Specifically formulated to provide long lasting resistance to U.V. light discoloration.
- Easy to clean with soap and water.
- Stacks for easy storage.

Product Specifications						
Product Description	Reference Number	Color	UPC Code 014306	Weight Each (lbs.)	Master Pack	Master Pack Volume (cu. ft.)
Sanibel Stacking Armchair	45451408	Teakwood	139890	10.30	12	40.42
	US451408	Teakwood	139890	10.25	4	16.92