



New Color!

Tempo Stacking Chair

Meets the performance standards of EN 581-1 and EN 581-2 for commercial use.

Tested in accordance with and passes each test procedure utilized in ASTM F 1561-96 Class B performance standard for commercial seating.

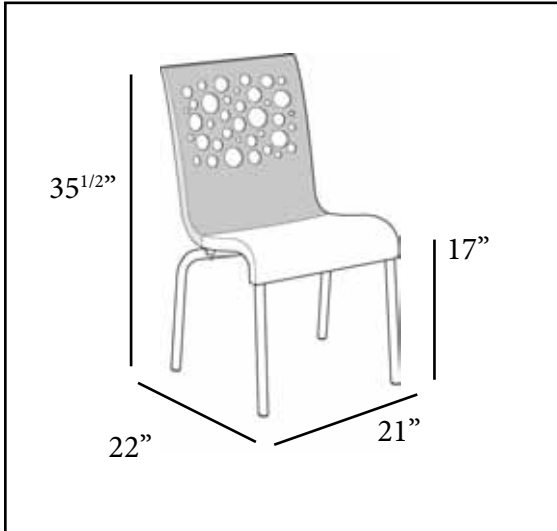

Features & Benefits **Warranty: 3 Yrs.**

- Unique, 2-color designer chair with a young & fun bubbly personality and european design.
- Strong metal legs and hard wearing footpads for extra stability.
- Indoor stacking chair specifically designed for versatility of use in many contemporary environments.
- Perfect for use in food courts, cafeterias, airports, shopping malls, hospitals, colleges, and universities.
- Stacks for easy storage.
- Easy to clean with soap and water.
- Rated to 300 lbs. for safe use.

Product Specifications

Product Description	Reference Number	Color	UPC Code 014306	Weight Each (lbs.)	Master Pack	Master Pack Volume (cu. ft.)
Tempo Stacking Chair	US210152	Fern Green/White	911830	14.10	12	47.80
	US021152	Fern Green/White	911830	13.45	4	21.60
	US210004	White/White	911847	14.10	12	47.80
	US021004	White/White	911847	13.45	4	21.60
	US214413	Beige/Taupe	911854	14.10	12	47.80
	US021413	Beige/Taupe	911854	13.45	4	21.60
	US210017	Black/White	911861	14.10	12	47.80
	US021017	Black/White	911861	13.45	4	21.60
	US210414	Red/White	911878	14.10	12	47.80
	US021414	Red/White	911878	13.45	4	21.60
<i>New Color!</i>	US210019	Orange/White	912004	14.10	12	47.80
	US021019	Orange/White	912004	13.45	4	21.60