

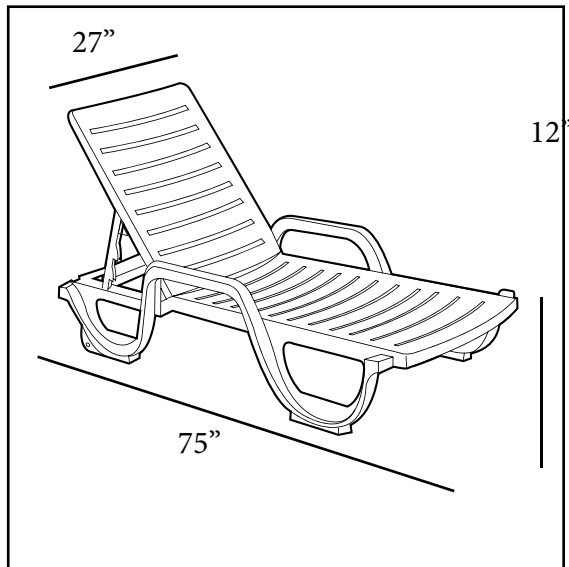

Special Packaging!

Bahia Stacking Adjustable Chaise

Passes ASTM F 1988-99 Class B performance standard for commercial outdoor lounging



Features & Benefits **Warranty: 3 Yrs.**

- Specifically made for commercial use.
- Twice the resistance to U.V. degradation than the ordinary market chaise.
- Reinforced slats and frame for extra support.
- Rated to 300 pounds for resistance to breakage under static load.
- Recessed roll-away wheels for easy mobility and quick storage.
- Stackable; easy to store.
- Built-in safety guard prevents finger injuries caused by accidental fall of the adjustable back.
- Longer sleigh glides to prevent accidental front tilt.
- Rounded edges and 4-position adjustable back.
- Impervious to salt water, chlorine and most common stains.
- A true contract chaise for the professional.

Product Specifications						
Product Description	Reference Number	Color	UPC Code 014306	Weight Each (lbs.)	Master Pack	Master Pack Volume (cu. ft.)
Bahia Stacking Adjustable Chaise	44031004	White	702193	29.17	6	51.90
	44031066	Sandstone	610764			
Special Packaging (Backrest is RTA)	44031104	White	139821	26.25	18	95.98
	44031166	Sandstone	107622			