



COMMERCIAL RESIN FURNITURE

Your best value for Food Service & Hospitality!

New!

I
N
T
E
R
I
O
R

Metro Stacking Chair

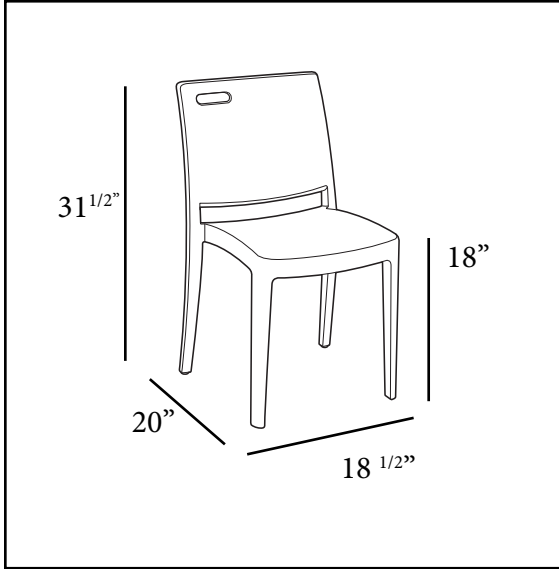

Passes ASTM F 1561-96 Class B
performance standard for commercial outdoor seating

Features & Benefits **Warranty: 3 Yrs.**

- Versatile, contemporary urban design.
- Low backrest with a wide ergonomic seat.
- Built-in handle for easy placement.
- Fine texture to resist scratches.
- Stacks for easy storage.
- Easy to clean with soap and water.
- Rated to 300 lb. for safe commercial use.

Product Specifications						
Product Description	Reference Number	Color	UPC Code	Weight Each (lbs.)	Master Pack	Master Pack Volume (cu. ft.)
New! Metro Stacking Armchair	XA653581	Linen	917795	10.25	16	34.11
	US653581	Linen	917795	11.16	4	21.52
	XA653202	Apple Red	917771	10.25	16	34.11
	US653202	Apple Red	917771	11.16	4	21.52
	XA653017	Black	917764	10.25	16	34.11
	US653017	Black	917764	11.16	4	21.52
	XA653096	Glacier White	917788	10.25	16	34.11
	US653096	Glacier White	917788	11.16	4	21.52
	XA653282	Cactus Green	917801	10.25	16	34.11
	US653282	Cactus Green	917801	11.16	4	21.52