

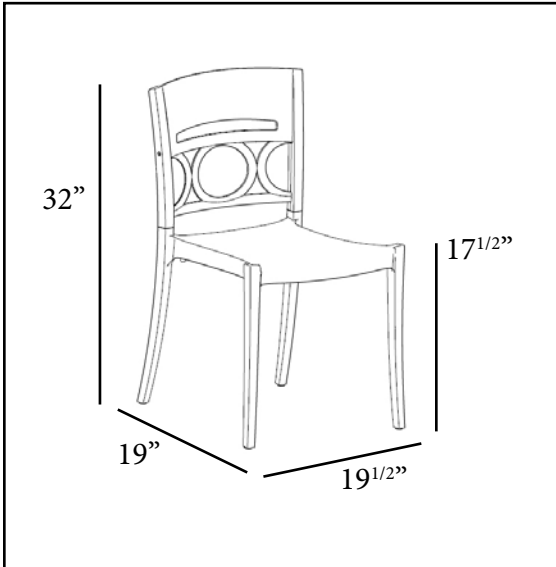

# New!

## Moon Stacking Chair

Passes ASTM F 1561 Class B standard for safe commercial outdoor use.



**Features & Benefits** **Warranty: 3 Yrs.**

- Contemporary two color rendition of a traditional cast design of the antique world.
- Low backrest with a wide ergonomic seat.
- Trendy colors to brighten the outdoor design scheme.
- Stacks for easy storage.
- Easy to handle and move around patios and terraces.
- Can easily be cleaned with soap and water.
- Rated to 300 lbs. for safe use in commercial environments.

<b>Product Specifications</b>						
Product Description	Reference Number	Color	UPC Code 014306	Weight Each (lbs.)	Master Pack	Master Pack Volume (cu. ft.)
<i>New!</i> Moon Stacking Chair	XA649096	Glacier White/Linen	917566	9.09	16	36.77
	US649096	Glacier White/Linen	917566	10.00	4	15.06
	XA649196	Storm Blue/Linen	917573	9.09	16	36.77
	US649196	Storm Blue/Linen	917573	10.00	4	15.06
	XA649282	Cactus Green/Linen	917580	9.09	16	36.77
	US649282	Cactus Green/Linen	917580	10.00	4	15.06
	XA650579	Titanium Gray/Charcoal	917597	9.09	16	36.77
	US649282	Titanium Gray/Charcoal	917597	10.00	4	15.06