

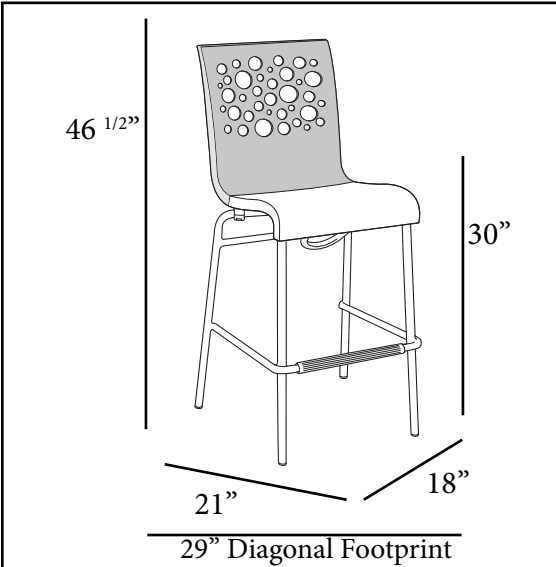

*New!*

INTERIOR



# Tempo Stacking Barstool

**Seat and footrest tested to 400 lbs. static load and 150 lb. impact test.**

**Features & Benefits** **Warranty: 3 Yrs.**

- Indoor stacking barstool specifically designed for versatility of use in many contemporary environments.
- Strong metal legs and hard wearing footpads for extra stability.
- Stacks for easy storage.
- Rated to 300 lbs. for safe use in commercial areas.
- Easy to clean with soap and mild detergent and water.
- Coordinates with Tempo Stacking Chair.

<b>Product Specifications</b>						
Product Description	Reference Number	Color	UPC Code	Weight Each (lbs.)	Master Pack	Master Pack Volume (cu. ft.)
<i>New!</i> Tempo Stacking Barstool	US310152	Fern Green/White	916828	17.25	8	66.60
	US031152	Fern Green/White	916828	17.60	2	19.30
	US310019	Orange/White	916873	17.25	8	66.60
	US031019	Orange/White	916873	17.60	2	19.30
	US310414	Red/White	916866	17.25	8	66.60
	US031414	Red/White	916866	17.60	2	19.30
	US310017	Black/White	916859	17.25	8	66.60
	US031017	Black/White	916859	17.60	2	19.30
	US314413	Beige/Taupe	916842	17.25	8	66.60
	US031413	Beige/Taupe	916842	17.60	2	19.30
	US310004	White/White	916835	17.25	8	66.60
	US031104	White/White	916835	17.60	2	19.30
	US310151	Eggplant/Linen	918273	17.25	8	66.60
	US031151	Eggplant/Linen	918273	17.60	2	19.30
	US310187	Raspberry/Linen	919355	17.25	8	66.60
	US031187	Raspberry/Linen	919355	17.60	2	19.30