

ALPA-99



a COOL business



Maintenance Free Condenser

The finless spiral condenser design prevents dust/dirt buildup allowing long term efficiency.



Steel Construction

Robust steel construction minimizes the use of plastic materials resulting in an environmental friendly design.



Electronic Temperature Control

The intelligent temperature control is programmed to ensure the correct operation of the equipment and maintain products at an optimum temperature.



LED Lighting

LED lighting lasts longer than fluorescent lighting, it reduces energy consumption and generates minimal heat. All of this makes LED lighting great for the environment.



Night Curtain

30% less energy consumption when closed.



Hot Gas Evaporation

Hot gas heated drain pan for condensate evaporation that eliminates the need of floor drains or electric heaters.



Custom Graphics

Standard color: grey. Optional: blue, red, white, or custom graphics.

CABINET CONSTRUCTION

- High-density, CFC-Free, polyurethane insulation
- Large low-E double pane tempered thermal glass side panels
- Manual retractable night curtain for increased energy savings
- Exterior: Galvanized metal cabinet with powder coated painted surface
- Interior: Easy to clean pre-painted steel

REFRIGERATION

- Maintenance free condensers
- Automatic defrost cycle
- Hot gas heated drain pan for condensate evaporation
- Electronic temperature control
- Easy to reach components for repairs
- R-134A Refridgerant

LIGHTING

- LED horizontal and vertical lighting

OPERATING CONDITIONS

- Open Air models should not be installed in any area where the air curtain will be disrupted. This includes placement near any HVAC vent, open doorway, or fan.
- The unit is rated for an environment where temperatures remain below 75°F and humidity does not exceed 55%.
- Areas with direct sunlight should also be avoided.

SHELVING

- Adjustable, dual-position shelves with tag molding.

OPTIONS

- 6" stainless steel legs
- Casters
- Lockable security cage
- Clear cool curtain
- Peg bar system for hanging product
- Shelf product retainers
- Custom graphics
- Saddle bag merchandisers
- Front product merchandiser

NEMA

- Required NEMA configuration: 5-20R

WARRANTY

- 2 year parts and labor
- 5 year compressor

Dimensions			Shelves	HP	Voltage	Amps	Crated Weight
L	D	H					
51.5 in 1318 mm	30 in 768 mm	62 in 1577 mm	2 x 3+	1/3	120	N/A	N/A
Crated Dimensions			Net Capacity, cf: 19.41		Energy Consumption: 15.82 kw-hr /day		
54 in 1370 mm	36 in 914 mm	65.5 in 1665 mm					

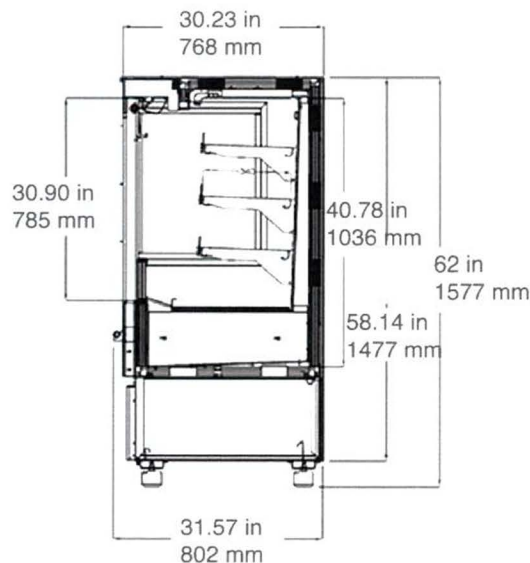
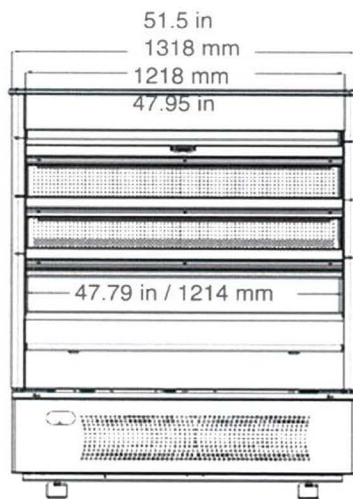

Saddle Bag



6 inch adjustable legs

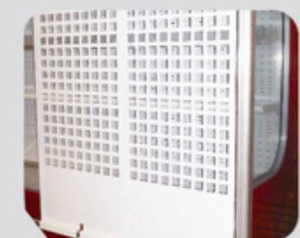

Lockable Security Cage