



FAT VAT™ Waste Oil Container

FAT VAT™ - Waste Oil Container

Project _____

Item No. _____

Quantity _____



STANDARD SPECIFICATIONS

CONSTRUCTION

- Two wheel roll around frame.
- Spring loaded cover helps hold cover fully open or closed.
- Built-in front legs allow for easy stand up storage.
- Light weight construction for easy transport and dumping.
- Built-in clip device under Fat Vat opening allows for hooking the Fat Vat to oil disposal container.

OPERATIONS

- Ensure that fryer is off.
- Open lid, lay container under fryer drain valve and open fryer drain lid.
- Drain used oil into FAT VAT
- Close the fryer drain valve.
- Close the FAT VAT lid and transport used oil easily by pushing or pulling the unit.
- Hook FAT VAT on oil disposal container and pour the used oil into the receptacle
- Clean FAT VAT with hot water and ammonia. Allow to air dry.

BENEFITS

- Helps eliminate oil spills
- Safely secures used oil for removal
- Convenient oil transport
- Holds 40 pounds / 18.1 KG / 5.3 gallons / 20.1 liters of oil

One year limited warranty



FAT VAT™ - Waste Oil Container

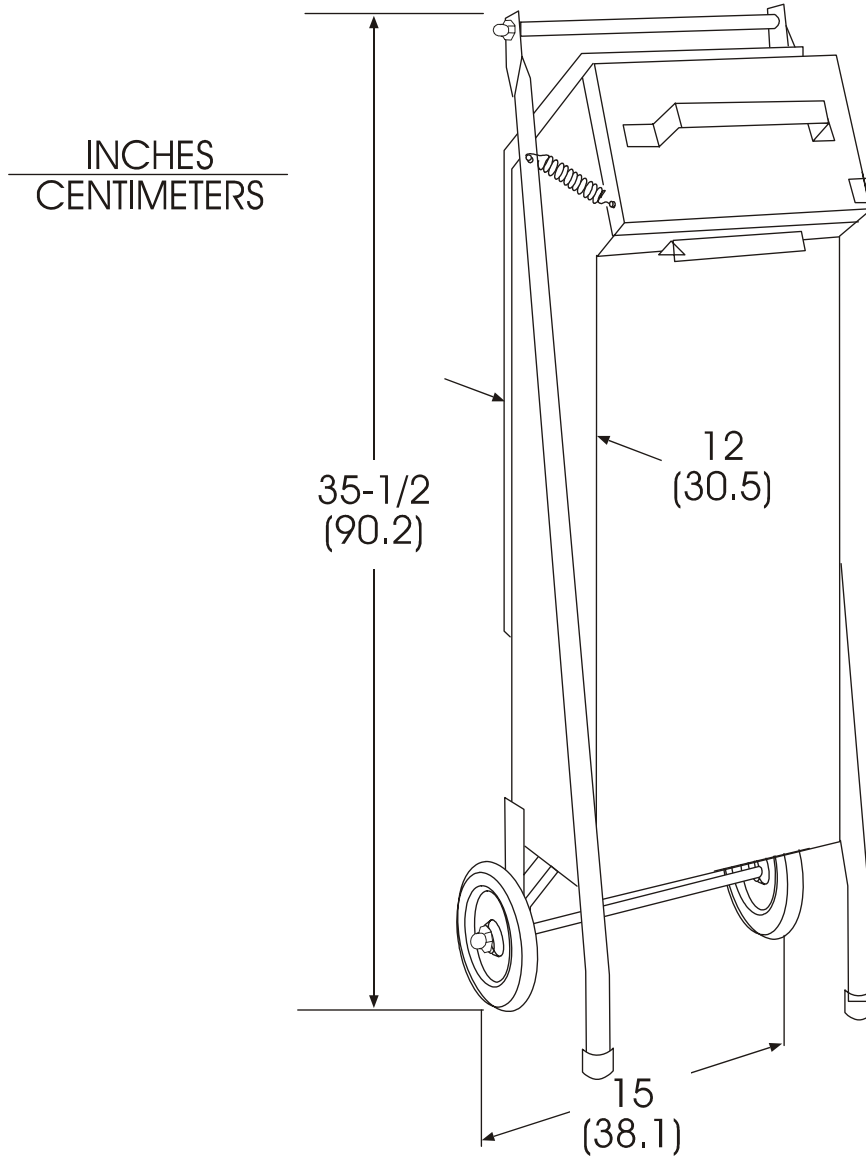

OIL CAPACITY		SHIPPING INFORMATION	
40 pounds (18.1 KG) or 5.3 gallons (20.1 liters)		16 pounds (7.3 KG) / 1.9 cubic feet (0.06 cubic meters)	
SHORT FORM SPECIFICATION			
Provide Pitco Fat Vat. Fat Vat shall have two frame mounted wheels. Fat Vat shall be able to hold 40 pounds (18.1 KG) of oil. Fat Vat shall have a spring loaded, hinged cover.			
TYPICAL APPLICATION			
Easy and safe transport of used oil.			



Pitco Frialator, Inc., P.O. Box 501, Concord, NH 03302-0501 • 509 Route 3A, Bow NH 03304, USA
(603) 225-6684 • Fax (603) 225-8472 • www.pitco.com

L10-040 Rev 3 (08/03) Specifications subject to change without notice.

Printed in the USA