



# FOOD WARMERS: MERCHANDISERS SUPREME™ HOT TOPPER

Model FSPW-SS



## BID DESCRIPTION

Supreme™ hot topping server features rounded corners and is constructed of a brushed (#4) stainless steel body with black thermoset plastic bottom and top. Dispenses directly from a 3 quart (2.8 L) stainless steel jar (not included) or from a manufacturer's #10 can. The pump features a cast valve body and welded construction and yields 1 ounce (30 mL). Gauging collars are supplied to reduce the yield in 1/8 ounce (3.7 mL) increments.

An adjustable, precalibrated thermostat controls the heating element. Features a "Power On" light and water fill line. Unit includes (3) magnetic merchandising signs: Caramel (86789), Cheese (86787) and Fudge (86788).

## STANDARD FEATURES

- NSF Listed as a rethermalization unit
- Pump design prevents loss of valve balls
- Yields 1 oz (30 mL) maximum portion, adjusts in 1/8 oz (3.7 mL) increments for Portion Optimization™
- Adjustable, precalibrated thermostat for accurate heat control
- Temperature marks on knob with protective knob guard
- Water fill line eliminates overflow accidents
- Includes magnetic signs for versatile merchandising

## ACCESSORY ITEMS

- 3 qt (2.8 L) Stainless Steel Jar 94009
- Stainless Steel Jar, Storage Lid 94008

 FSPW-SS 81140



ALSO AVAILABLE FOR EXPORT

## TWO YEAR WARRANTY

Server Products equipment is backed by a two-year limited warranty against defects in materials and workmanship. For a copy of our complete warranty statement, please refer to [server-products.com](http://server-products.com).

# FOOD WARMERS: MERCHANDISERS

## SUPREME™ HOT TOPPER

Model FSPW-SS

### SUPREME™ SERVER WITH SPOUT WARMER AND PUMP

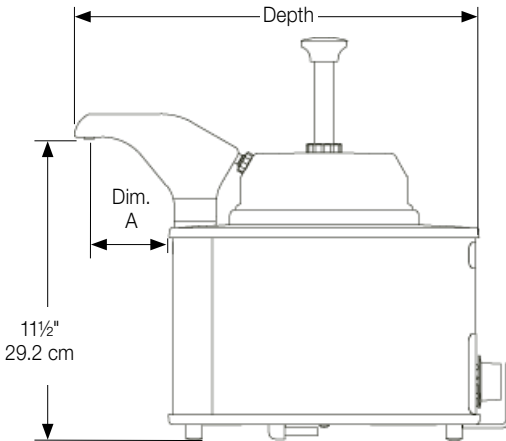
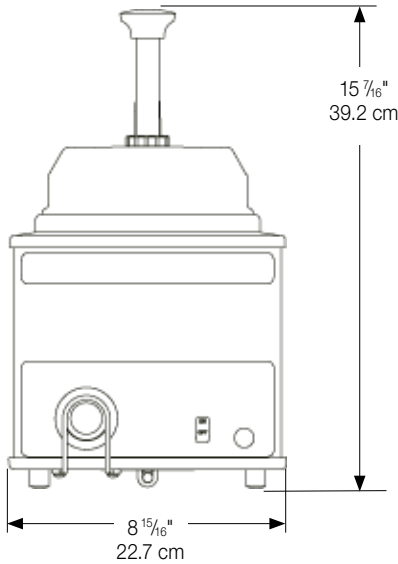

### SPECIFICATIONS

Construction	Stainless steel base with black thermoset plastic bottom and top. Pump features a rugged cast valve body and welded construction.			
Certifications	NSF, NSF Rethermalization, C UL US NSF listing for rethermalization ensures food is quickly heated to a safe temperature before bacteria has an opportunity to grow. 			
Capacity	Jar holds 3 quarts (2.8 L) — not included.			
Dimensions	<u>Height</u>	<u>Width</u>	<u>Depth</u>	<u>Dim A</u>
	15 <sup>7</sup> / <sub>16</sub> " 39.2 cm	8 <sup>15</sup> / <sub>16</sub> " 22.7 cm	15 <sup>1</sup> / <sub>2</sub> " 39.4 cm	3 <sup>1</sup> / <sub>16</sub> " 7.8 cm
Electrical	120V, 60Hz, 517W, 4.3A, 72 in (183 cm) cord set NEMA 5-15P, 15A, 125V PLUG			
Weight	15 lb (6.8 kg)			

FOB RICHFIELD, WISCONSIN 53076

### CAD LIBRARY

Individual CAD images can be downloaded from our website. We are also a member of The KCL CADalog with more than 100 other manufacturers. Our complete collection of CAD files can be purchased through Kochman Consultants, Ltd. at [kclcad.com](http://kclcad.com).