



COLD FOOD HOLDERS THERMOELECTRIC CHILLERS, 1/3 PAN

Models CC-1/3, CC-1/3 NL Combo & CC-1/3 NL



CC-1/3 86080*
* SHOWN WITH (3) 1/9-SIZE JARS (87203), NOT INCLUDED



CC-1/3 NL COMBO 86006**
** INCLUDES (3) 1/9-SIZE JARS (87203), CLEAR LIDS (87253) AND SPOONS (85156)
ALSO AVAILABLE WITHOUT ACCESSORIES - CC-1/3 NL (86140)

BID DESCRIPTION

The CC - 1/3 countertop chillers are designed to cool up to a 1/3 - size steam table pan, 6" (15.2 cm) deep with a 6 quart capacity. Configure with standard fractional pans up to 1/3 - size or (3) Server Products 1/9 - size jars, 6" (15.2 cm) deep with a 1.9 quart (1.8 L) capacity each. Models available with or without a black double-walled hinged lid or complete with jars, lids and spoons.

Thermoelectric cooling provides quiet, efficient operation and consistently holds product below 41° Fahrenheit (5° C). Internal temperature is displayed on a digital readout. An ON/OFF rocker switch controls the cooling mechanism.

STANDARD FEATURES

- Stainless steel base; black plastic hinged lid
- Thermoelectric power is quiet and efficient
- Holds consistently below 41°F (5°C) — to keep product inside fresh and cold
- Configurable to hold fractional pans up to 1/3-size or (3) 1/9-size jars, 6" (15.2 cm) deep
- 7 foot (2.1 m) power cord

ACCESSORIES

- 1/9-Size Jar 3 1/2" (8.9 cm), Black Plastic 87202
- 1/9-Size Jar 6" (15.2 cm), Black Plastic 87203
- Hinged Lid for 1/9-Size Jars, Clear Plastic 87253
- Spoon, 4" (10.2 cm) Handle, Clear Plastic 85156
- Ladle, 4" (10.2 cm) Handle, Stainless Steel 82717
- Ladle, 6" (15.2 cm) Handle, Stainless Steel 87213
- Pumps for 1/9-Size Jars also available



ALSO AVAILABLE FOR EXPORT

[Click here to buy now!](#)



1-866-285-1252

TWO YEAR WARRANTY

Server Products equipment is backed by a two-year limited warranty against defects in materials and workmanship. For a copy of our complete warranty statement, please refer to server-products.com.

COLD FOOD HOLDERS THERMOELECTRIC CHILLERS, 1/3 PAN

Models CC-1/3, CC-1/3 NL Combo & CC-1/3 NL

CHILLERS

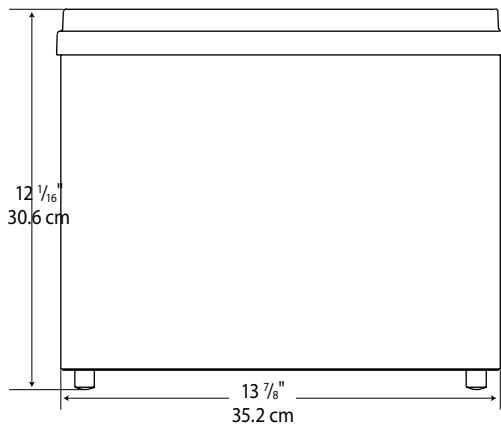
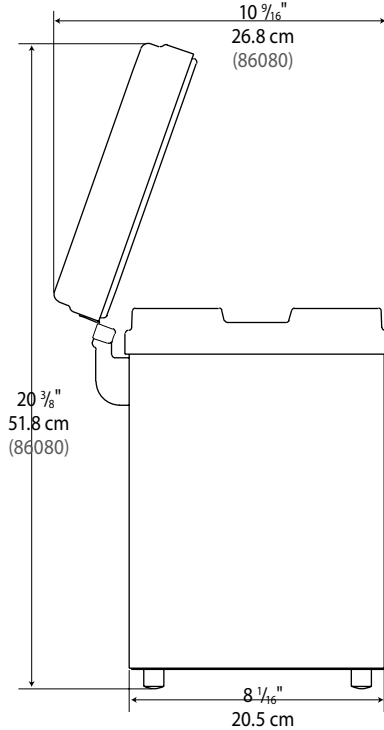

MODELS	CC-1/3, NL & COMBO (86080, 86140,86006)
Capacity	Accepts 1/3-size steam table pan, 6" (15.2 cm) deep with a 6 qt capacity
Height	12 ¹ / ₁₆ " 30.6 cm
Width	13 ⁷ / ₈ " 35.2 cm
Depth	8 ¹ / ₁₆ " 20.5 cm
Electrical	Power supply converts 120V 1 Amp AC to 12V DC power with 7' (2.1 m) power cord NEMA 5-1 5P, 15A, 125V PLUG
Weight	26 lb 11.8 kg

FOB RICHFIELD, WISCONSIN 53076

CAD LIBRARY

Individual CAD images can be downloaded free of charge from our website. Our complete collection of CAD files, along with more than 100 other manufacturers, can be purchased through Kochman Consultants, Ltd. at kclcad.com.