

Light-Duty Vegetable Prep and Vertical Cutter-Mixer



Prepare 400 servings in 3 hours or less!

Vegetable prep function - internal injection designed for quality, slicing, shredding, grating, french fry, and julienne cuts. Accommodates 21 different

processing discs. Bowl attachment designed for mixing, chopping, pureeing, and blending.



- Two machines in one.
- Mechanical safety system and motor brake.
- Direct Drive, fan-cooled, 3/4 HP motor.
- Large range of 21 stainless steel processing discs to choose from.
- 2.5 Qt. gray cutter bowl with see-thru lid.
- Lid has two deep feed openings.
- Attachments easily removed for superior cleanability.
- Unit base uses minimal counter space (9" x 14").
- Standard package includes two processing discs (27577 - 2mm grating and 27566 - 4mm slicing)
- 1 year parts and labor warranty.

Robot Coupe U.S.A., Inc.
P.O. Box 16625
Jackson, MS 39236-6625
1-800-824-1646 • (601) 898-8411
FAX: (601) 898-9134
www.robotcoupeusa.com
e-mail: info@robotcoupeusa.com

SPECIFICATIONS ON REVERSE SIDE

Specifications

STANDARD MODEL: Includes motor base unit, 2.5 Qt. grey cutter bowl with stainless steel "S" blade, see-thru lid with two deep feed openings, one 5/32" (4mm) slicing disc, and one 5/64" (2mm) medium grating disc .

ELECTRICAL REQUIREMENTS: 120V, 60HZ, 7 Amps. NEMA #5-15P.

SWITCHING: Control panel with push-type on/ off buttons.

MOTOR: 3/4 HP, 1725 RPM, direct-drive, fan-cooled.

WEIGHT: 21 lbs. net, 25 lbs. approximate shipping weight.

OPTIONAL EQUIPMENT: 19 additional processing discs and free standing multiple disc rack.

STANDARDS: ETL electrical & sanitation, cETL (Canada)

Available Discs

Slicing Discs

- 27051 - 1/32" (1mm)
- 27555 - 5/64" (2mm)
- 27086 - 1/8" (3mm)
- 27566 - 5/32" (4mm)
- 27087 - 3/16" (5mm)
- 27786 - 1/4" (6mm)

Ripple Cut Slicers

- 27621 - 5/64" (2mm)

Graters

- 27588 - 1/16" (1.5mm)
- 27577 - 5/64" (2mm)
- 27511 - 1/8" (3mm)
- 27046 - 1/4" (6mm)
- 27632 - 11/32" (9mm)
- 27078 - Hard Cheese Grate

Pulping

- 27079 - Fine pulping disc
- 27764 - Pulping disc

Julienne

- 27599 - 5/64" (2x2mm)
- 27080 - 5/64" x 5/32" (2x4r)
- 27081 - 5/64"x1/4" (2x6mm)
- 27047 - 5/32" (4x4mm)
- 27610 - 1/4" (6x6mm)
- 27048 - 5/16" (8x8mm)

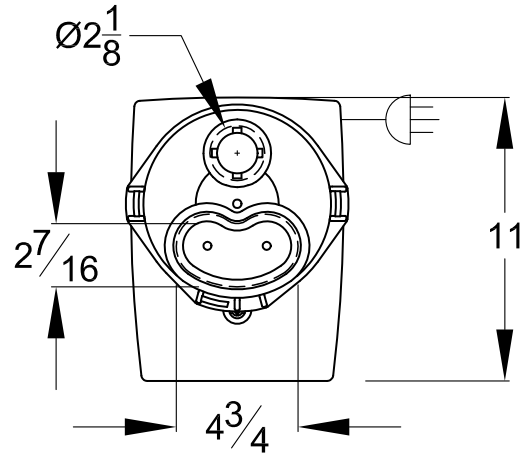
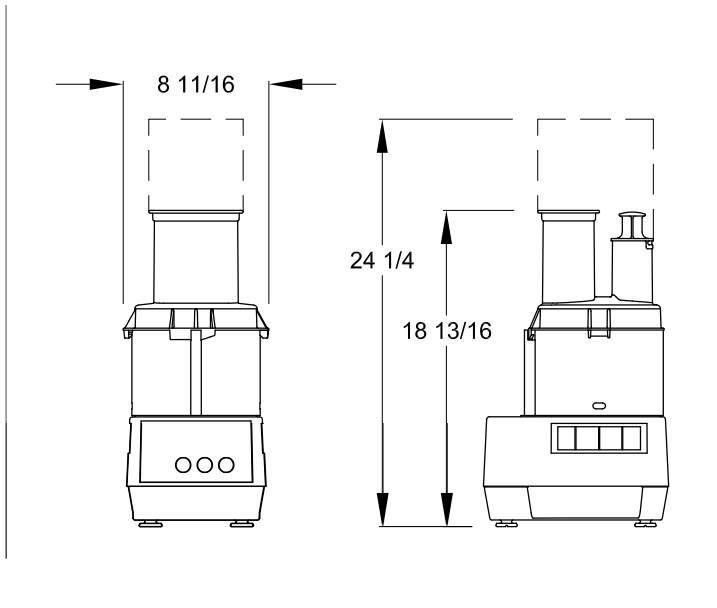

Robot Coupe U.S.A., Inc.
P.O. Box 16625
Jackson, MS 39236-6625
1-800-824-1646
(601) 898-8411
FAX: (601) 898-9134
www.robotcoupeusa.com
e-mail: info@robotcoupeusa.com

Distributed by: