

Vertical Cutter-Mixer



R10U- bowl-
within-a bowl

R10

10 Quart Stainless Steel bowl designed for vertical cutting and mixing: puree, mix, chop, and blend. R10U functions as above with 10 Quart and 3.5 Quart bowls

- R10 unit has 10 quart stainless steel cutter bowl with adjustable 3-knife assembly. R10U has 10 quart stainless steel bowl with knife assembly as well as a 3.5 quart mini stainless steel bowl with knife assembly to fit inside larger bowl for smaller batches.
- "Stock-pot" shaped stainless steel bowl facilitates processing
- Adjustable 3-blade knife assembly provides efficient processing from 16 oz to 10 lbs.
- Safety mechanism prohibits operation unless bowl and lid are properly locked in position.
- "See-thru" lid is vented for safety with built-in drip tray, air-tight seal and funnel.
- Self-centering cutter bowl with only one locking knob.
- R10/R10U has 3 HP on low speed and 4.5 HP on high speed, 3 phase, 2 speed motor
- Unit base uses 26 5/16" x 14 1/2" of counter space.
- 1 year parts and labor warranty.

Specifications

STANDARD MODEL:

R10 - Motor Unit with 10 qt. stainless steel cutter bowl and adjustable 3-blade knife assembly, two speed.

R10U - Motor Unit with 10 qt. stainless steel cutter bowl with adjustable 3-blade knife assembly and 3.5 stainless steel mini bowl assembly with knife assembly, two speed.

ELECTRICAL REQUIREMENTS: 208-240V, 60 HZ, 9-12.5 Amps, Three phase, 4.5 HP, 2 speed, 1725/3450 rpm. Includes built-in overload protection. Minimum branch circuit protection recommended; 20 Amps. Nema #L15-20P.

SWITCHING: Magnetic safety switch, two speed control, push-button "ON-OFF", pulse control and power indicator lights.

MOTOR: 4.5 HP, Three phase, 2 speed 1725/3450 RPM,

WEIGHT: R10 - 150 lbs. approximate shipping weight.
R10U - 157 lbs. approximate shipping weight.

STANDARDS: ETL electrical & sanitation

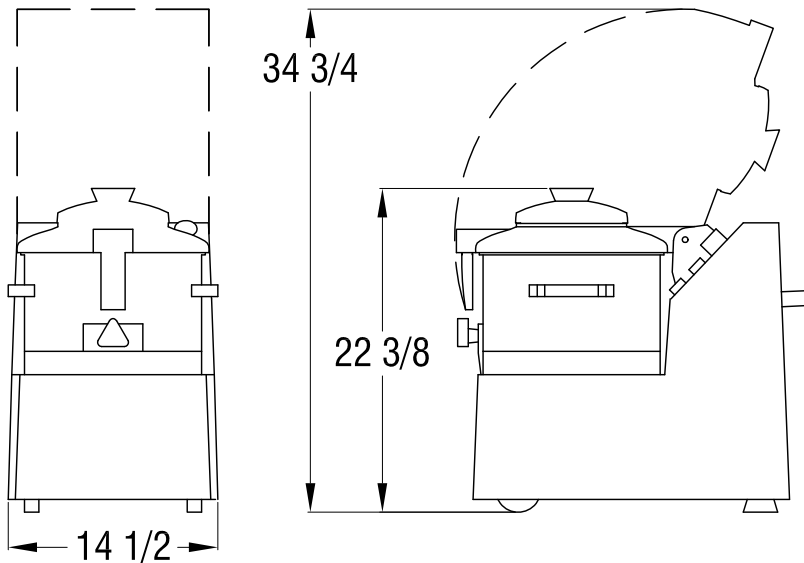
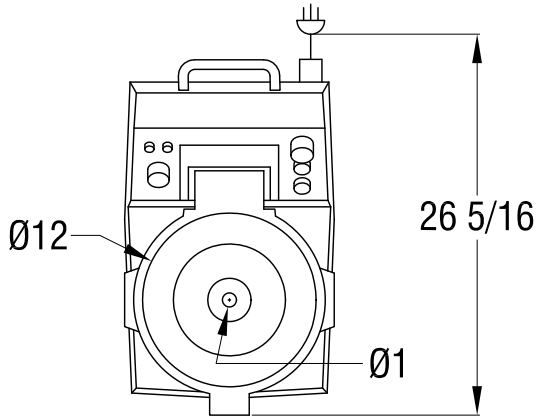

Robot Coupe U.S.A., Inc.
P.O. Box 16625
Jackson, MS 39236-6625
1-800-824-1646
(601) 898-8411
FAX: (601) 898-9134
www.robotcoupeusa.com
e-mail: info@robotcoupeusa.com

Distributed by: