

Juicer

New



2 ways of using your juicer:

1 Continuous pulp ejection.

Ejection chute sending continuous flow of pulp directly into bin under worktop.



2 Pulp ejected into container

7.2-litre large-capacity translucent pulp container



1 Pulp ejected directly into a bin beneath the worktop:



- Ultra-powerful 1000 watt, 1.25 H.P. single phase industrial synchronous motor with magnetic safety switch and highly efficient ventilation system for non-stop juicing. 3450 rpm.
- Stainless steel motor base.
- Push button "On-Off" switches.
- Basket includes 2.5 mm grating disc and 2 handles to easily remove with no tools necessary.
- Comes with 7.2 Qt waste container and ejection chute that sends a continuous flow of pulp directly into a bin beneath the worktop.
- Drip tray and anti-drip spout.
- Attachments easily removed for optimum cleaning.
- Unit base uses 16 1/2" x 9 1/4" of counter space.
- Tall enough for blender bowl to be positioned under juice spout.
- 1 year parts and labor warranty.



Easy-clean, easy grip, two-handled basket requiring no



Drip tray ensuring that the worktop stays clean at all



No-splash juice spout.

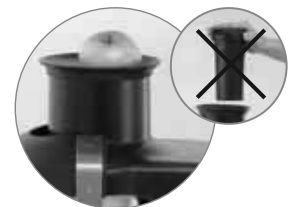

Auto Feed system (Ø79 mm) allowing fruit and vegetables



Robot Coupe U.S.A., Inc.

P.O. Box 16625

Jackson, MS 39236-6625

1-800-824-1646 • (601) 898-8411

FAX: (601) 898-9134

www.robotcoupeusa.com • e-mail: info@robotcoupeusa.

Specifications

STANDARD MODEL: includes stainless steel motor base unit with ABS plastic lid, anti-drip spout, 2.5 mm basket, 7.2 Qt waste container, ejection chute for continuous flow and drip tray.

ELECTRICAL REQUIREMENTS: 120V, 60Hz, single phase. Contact your local electrician for local code requirements.

SWITCHING: Control panel with push-type on and off buttons.

MOTOR: 1.25 HP, 3450 RPM.

STANDARDS: ETL electrical & sanitation, cETL (Canada)

Dimensions in mm

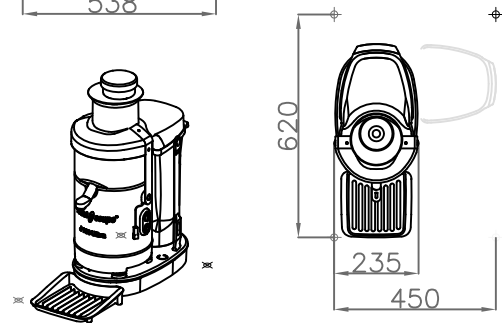
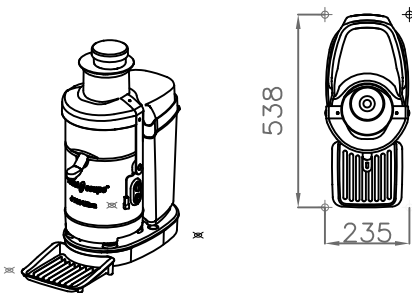
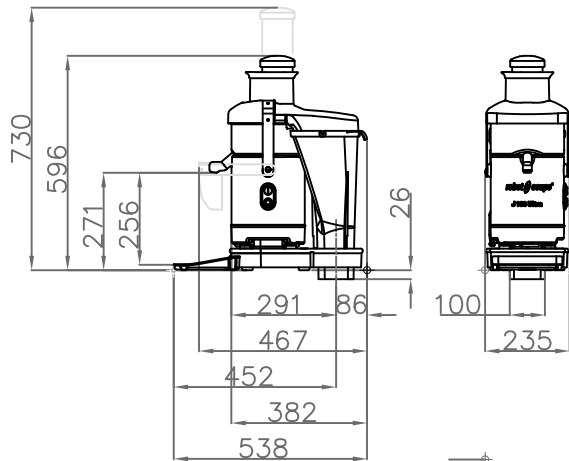
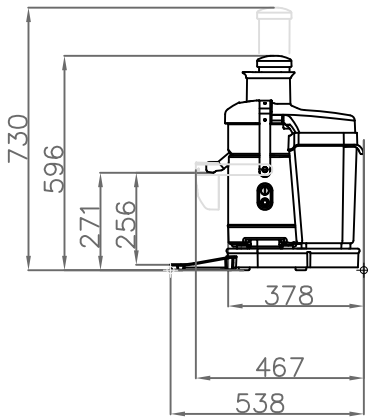

Robot Coupe U.S.A., Inc.
P.O. Box 16625
Jackson, MS 39236-6625
1-800-824-1646
(601) 898-8411
FAX: (601) 898-9134
www.robotcoupeusa.com
e-mail: info@robotcoupeusa.com

Distributed by: